

Catalogo Generale
Manuale Lavorazioni



INDICE

Introduzione Tecnica	
Elenco Accessori	
Elenco Guarnizioni	
Elenco Attrezzature	
Profilati ed Inerzie	
Profilati Scala 1:1	
Soluzioni Disponibili	
Schede di Taglio	
Nodi Scala 1:1	
Icone Lavorazioni	
Tipologie Realizzabili	
Schemi Applicazione Accessori	
Lavorazioni	
Informazioni Tecniche	

**FINO A NUOVA STAMPA CARTACEA GLI AGGIORNAMENTI
SONO DISPONIBILI SUL SITO WWW.INDINVESTLT.IT**



Introduzione Tecnica

CATALOGO TECNICO - INDICAZIONI GENERALI

MANUALE D'USO

Le informazioni contenute all'interno di questo Catalogo / Manuale, quando seguite scrupolosamente, permettono la realizzazione di infissi efficienti, sicuri e di lunga durata.

Alcune parti di questa documentazione, come ad esempio le distinte di taglio dei profilati, sono il risultato di calcoli teorici che possono risentire di fattori esterni, quali tipo e spessore della finitura superficiale, modello delle attrezzature utilizzate etc. E' quindi sempre consigliato, prima di procedere alla realizzazione delle commesse, eseguire una campionatura preventiva di prova in dimensioni reali, allo scopo di verificare lavorazioni, assemblaggi e prestazioni.

RISERVE GIURIDICHE

I disegni e le informative contenute in questo catalogo sono fornite a solo titolo indicativo e non possono costituire titolo di rivalsa nei confronti della INDINVEST LT s.r.l. INDINVEST LT s.r.l. declina ogni responsabilità su eventuali errori di stampa o sull'uso improprio del presente catalogo e si riserva la facoltà di modificarne il contenuto senza alcun obbligo di preavviso.

Il presente catalogo è di proprietà della INDINVEST LT s.r.l. così come i suoi contenuti ed immagini che non potranno essere copiati e riprodotti, anche solo parzialmente, o modificati in alcun modo senza la Sua autorizzazione scritta.

DIMENSIONE E PESO DEI PROFILATI

Le dimensioni dei profilati riportate sul presente catalogo sono teoriche, e quindi variabili in funzione delle tolleranze dimensionali di estrusione (in conformità alla norma UNI EN 12020-2:2017), oltreché in conseguenza di trattamenti di finitura superficiale e di accoppiamento dei profili a taglio termico. Dette variazioni possono influenzare sensibilmente gli accoppiamenti dei profili e/o la facilità di inserimento di accessori o guarnizioni nelle sedi apposite.

Le barre dei profilati vengono fornite alla lunghezza di 6.80 m.

POSA IN OPERA

Nella posa in opera dei serramenti, è necessario valutare opportunamente la tolleranza da mantenere tra il contro-telaio ed il telaio in Alluminio.

Questa tolleranza è variabile secondo le condizioni presenti, ma deve essere comunque tale da garantire un fissaggio completo e sicuro.

L'attacco dei serramenti alle murature presenta varie possibilità di soluzione a seconda della situazione che si presenta, ma deve avvenire con viti, tasselli ed ancoraggi di buona qualità secondo le normali e consolidate regole della buona posa e del buon senso.

Gli schemi, le lavorazioni, le sezioni e gli attacchi a muro riportati sul presente catalogo hanno valore esemplificativo e non limitativo; essi riguardano, infatti, solo una parte delle casistiche riscontrabili all'atto pratico, che sarebbero altrimenti troppo numerose da citare nella loro interezza.

A fronte di ciò, Indinvest riterrà correttamente installati quei serramenti che utilizzino le tecniche di fissaggio contenute e descritte nella pubblicazione UNCSAAL UX42 "Guida alla Posa in Opera dei Serramenti".

GUARNIZIONI ED ACCESSORI

Dovranno essere utilizzate esclusivamente le guarnizioni e gli accessori originali studiati e prodotti a garanzia delle prestazioni del sistema. L'impiego di guarnizioni o accessori diversi da quelli indicati comporteranno l'inutilizzabilità dei certificati di prova.

SIGILLANTI

Dovranno essere utilizzati esclusivamente sigillanti con caratteristiche conformi a quanto prescritto dalle norme di riferimento Europee UNI EN ISO 11600:2011 , UNI EN 15651:2017, UNI 11673-1:2017 e 13501:2019.

LAVORAZIONI

Le lavorazioni per l'assemblaggio dei profili dovranno essere praticate seguendo gli schemi, le distinte e le istruzioni impartite dal produttore del sistema. La realizzazione di infissi costruiti in difformità dalle indicazioni di montaggio fornite dal produttore di sistema comporteranno l'inutilizzabilità dei certificati di prova.

Allo scopo di limitare il processo di corrosione filiforme dell'alluminio si dovrà avere cura di utilizzare soltanto viterie in acciaio inox ed accessori supplementari in acciaio inox o alluminio in lega EN AW6060, oltre che sigillare le parti tagliate ed evitare ristagni di condensa interni.



<http://www.uncsaal.it>

VERNICIATURA

I profilati dovranno subire trattamenti superficiali conformi agli standard QUALICOAT e QUALANOD ed in caso di verniciatura dei profilati a taglio termico si dovranno supportare gli stessi con mezzi opportuni affinché non subiscano deformazioni durante il trattamento di cottura del rivestimento a 180° mantenendo l'originale rettilineità.

CARATTERISTICHE DELLE VETRAZIONI

La scelta della vetratura da installare sui serramenti realizzati con il sistema oggetto del catalogo dovrà essere effettuata secondo criteri prestazionali per rispondere ai requisiti di sicurezza, di risparmio energetico, di controllo della radiazione solare e di isolamento acustico fissati dalle leggi vigenti. Riferimenti normativi europei: UNI EN 10140-2:2021 ; UNI EN 12488:2016; UNI EN 572:2016; UNI EN 12758:2019; EN ISO 12543-1/6 2011; UNI EN 12150-1:2019.

ISOLAMENTO TERMICO

La scelta delle prestazioni di isolamento termico di un serramento dovrà essere effettuata in conformità alla vigente normativa italiana in materia di risparmio energetico: legge 10 del 09.01.1991, D.L. 192/05 e D.L. 311/06 e loro successive modifiche ed integrazioni.

La trasmittanza termica di un serramento può essere calcolata in riferimento a quanto contenuto nella norma UNI EN 13830:2020; UNI EN ISO 12631: 2018 e per il calcolo secondo le modalità di calcolo riportate nella UNI EN 10077-1-2:2018

ISOLAMENTO ACUSTICO

La scelta della classe di isolamento acustico di un serramento sarà legata alla destinazione d'uso del locale nel quale l'infisso dovrà essere inserito, oltre che al livello ed alla natura del rumore esterno. Le prestazioni acustiche del serramento in opera sono influenzate da fattori noti (classe di permeabilità all'aria dell'infisso, potere fono isolante del vetro) e da fattori non definibili a priori (altezza dal suolo, presenza di parapetti, orientamento delle sorgenti, sporgenze, spettro sonoro, modalità d'installazione. I valori da rispettare sono quelli indicati dalla vigente normativa italiana (D.P.C.M. 05/12/1997) misurabili secondo e le relative norme europee : (UNI EN 572-1:2016 UNI EN 717-1:2021 e UNI EN 12758:2019.

SICUREZZA SUL LAVORO

Le procedure di realizzazione e montaggio in sicurezza dei serramenti, nel rispetto della normativa italiana in tema di salute e sicurezza D.Lgs. 81/08 e s.m.i, sono a cura dei serramentisti. I serramenti dovranno essere concepiti secondo le prescrizioni della normativa vigente (UNI EN 572- 1:2004 e UNI 7697:2007) italiana ed europea in materia di sicurezza delle applicazioni vetrarie e della UNI in materia di marchio CE. UNI EN 572 1:2004 Vetro per edilizia - Prodotti di base di vetro di silicato sodio-calcico - Parte 1: Definizioni e proprietà generali fisiche e meccaniche UNI 7697:2007 Criteri di sicurezza nelle applicazioni vetrarie UNI ENE 14351-1:2006 Finestre e porte - Norma di prodotto, caratteristiche prestazionali - Parte 1: Finestre e porte esterne pedonali senza caratteristiche di resistenza al fuoco e/o di tenuta al fumo.

LIMITI D'IMPIEGO

Le dimensioni massime dei serramenti, dei pesi delle ante e degli accessori riportate in questo catalogo sono da verificarsi e da determinarsi a cura del costruttore in funzione della geometria dei profilati, della massa , del peso delle vetrazioni/pannellature, della qualità e della portata degli accessori utilizzati, delle condizioni d'installazione, delle condizioni di applicazione (altezza dal suolo, esposizione, ecc.), e delle condizioni climatiche (velocità di riferimento dei venti, esposizione alla pioggia, ecc.). al costruttore di serramenti si consiglia di fare riferimento alle "Raccomandazioni UNCSAAL" elaborate sulle base delle vigenti normative europee ed italiane.

CONSIGLI COSTRUTTIVI PER LIMITARE L'INSORGENZA DI CORROSIONE:

La corrosione filiforme è uno dei problemi più insidiosi che possano manifestarsi nei profilati in Alluminio. Al fine di contrastarne l'insorgenza, occorre prestare particolare attenzione ad alcuni aspetti in fase di costruzione e posa degli infissi.

In particolare:

Nei limiti del possibile utilizzare per le giunzioni squadrette e cavallotti in Alluminio estruso, lega 6060 o pressofuso, lega UNI 5076.

Le viti di fissaggio devono essere in acciaio inox.

Le parti soggette a taglio o fresature devono essere sigillate accuratamente, con specifici prodotti adatti allo scopo (colle bicomponente ecc.).

Evitare ristagni di acqua (spesso dovuti a fenomeni naturali di condensa), all'interno dei profilati.

SITO INTERNET ED AGGIORNAMENTI

Per aggiornamenti del catalogo e per ogni ulteriore informazione è possibile visitare il nostro sito internet all'indirizzo: WWW.INDINVESTLT.IT

DIMENSIONE MINIMA ANTA

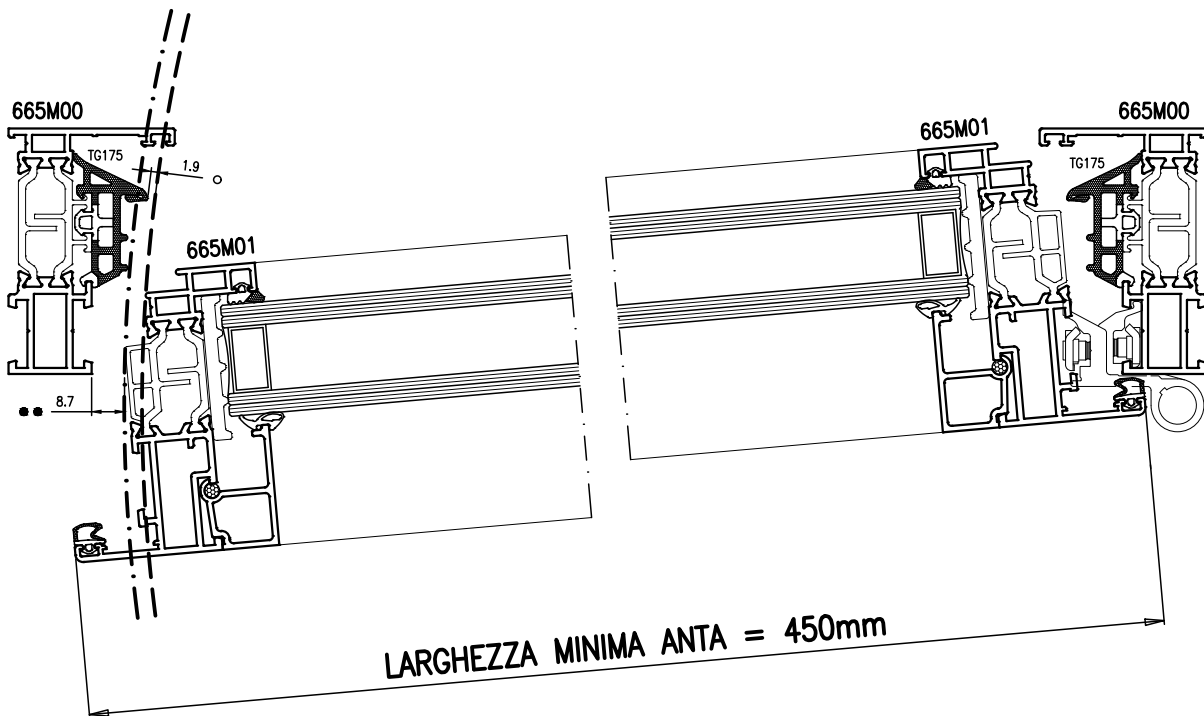

CON LARGHEZZA ANTA = 450 mm

- TRA LA GUARNIZIONE TG175 E IL PROFILATO IN ROTAZIONE RIMANE UNO SPAZIO TEORICO DI POCO MENO DI 2 mm
- IL PROFILATO IN ROTAZIONE LASCIA UNO SPAZIO UTILE PER GLI ACCESSORI DI CHIUSURA (RISCONTRI, ECC.) SUPERIORE A 8mm

DESCRIZIONE PER CAPITOLATO

Serramenti costruiti con profilati estrusi in lega di alluminio 6060 (EN 573-3), con stato di fornitura T6 (EN 515) e tolleranze su dimensioni e spessori secondo UNI EN 12020.2 e/o UNI EN 755-9.

Il telaio fisso avrà una profondità di 65 mm. e quello mobile di 75 mm. così da assicurare una maggiore resistenza strutturale alle elevate pressioni del vento. La tubolarità in cui sono contenute le squadrette di giunzione degli angoli avrà una larghezza di 12 mm., comprensivi di spessore delle pareti del profilato, sia per i telai fissi che per quelli mobili. L'aletta di sovrapposizione al muro nella parte interna non dovrà essere inferiore a 26 mm. e dovrà avere una sede per l'alloggiamento della guarnizione di battuta. I profilati avranno caratteristiche di taglio termico, cioè vi sarà separazione tra parte esterna ed interna dei profilati stessi, al fine di contenere il passaggio di calore tra le due parti. Il taglio termico dovrà essere ottenuto mediante l'inserimento di listelli complanari in poliammide rinforzata con fibre di vetro, della profondità totale di 34 mm per il telaio e 30 mm per l'anta. e spessore di 2 mm. In caso di necessità dovrà essere possibile l'inserimento di ulteriori listelli in materiale isolante ed autoespandente. Il bloccaggio delle barrette sarà meccanico, con rullatura dei dentini di ancoraggio dall'esterno previa loro ziggrinatura per evitare scorrimenti. La superficie in vista della configurazione standard dovrà essere di 70mm.

Il valore della trasmittanza termica U_f nella configurazione standard non dovrà essere superiore a 1,7 W/m²K per la sezione laterale e 1,8 W/m²K per la sezione centrale.

DOGMA SLIM

Il sistema di tenuta all'aria sarà a giunto aperto, cioè con guarnizione centrale in E.P.D.M. in doppia densità montata sul telaio fisso che va ad appoggiare sull'apposita pinna in poliammide presente sul telaio mobile. Inoltre per ridurre la trasmissione termica e per garantire sempre la corretta ventilazione perimetrale del vetrocamera il perimetro dei tamponamenti (vetro o pannello) sarà contornato da apposita guarnizione isolante in PEX, mentre quello del telaio da guarnizione auto espandente in poliuretano.

Nella traversa inferiore del telaio fisso dovranno essere realizzate delle asole per lo scarico dell'acqua, dotate di apposite cappette in nylon di protezione. Gli angoli dei profilati e della guarnizione centrale dovranno essere incollati per garantire la tenuta meccanica e assicurare la continuità per la tenuta all'aria e all'acqua.

In caso di utilizzo di vetri isolanti, nelle traverse inferiori e nei montanti laterali delle ante mobili dovranno essere realizzate altresì asole per lo scarico dell'eventuale acqua di condensa e per la corretta aerazione del vetro.

Il serramento finito presenterà una superficie esterna piana (complanare), con fughe tra telaio fisso e mobile di 5 mm. mentre all'interno il piano delle ante apribili avrà una sporgenza (sormonto) di 10 mm. rispetto al piano del telaio fisso.

I fervevetro saranno a contrasto sui profilati a sezione ridotta e a scatto sugli altri e avranno apposite sedi per l'inserimento delle guarnizioni.

Gli accessori e le guarnizioni dovranno essere quelli originali, studiati e prodotti per questo sistema di profilati. Per quanto riguarda la tenuta all'aria, all'acqua ed al vento i serramenti dovranno garantire le seguenti classi di tenuta per le portabalcone ad una e due ante:

Permeabilità all'aria:	classe 4	UNI EN 1026	UNI EN 12207
Tenuta all'acqua:	classe E1350	UNI EN 1027	UNI EN 12208
Resistenza al vento:	classe C4	UNI EN 12221	UNI EN 12210

L'ottenimento delle caratteristiche di tenuta sopraccitate con questi profilati dovrà essere dimostrabile con riproduzione in copia dei risultati del collaudo presso idoneo Istituto, effettuato dal costruttore dei serramenti o, in mancanza, dal produttore dei profilati.

Finitura superficiale dei profilati in alluminio

La protezione e la finitura delle superfici dei profilati dovranno essere effettuate mediante anodizzazione o verniciatura.

- L'anodizzazione, nel colore _____ dovrà essere eseguita secondo quanto previsto dal marchio europeo "EURAS-EWAA / QUALANOD".
- La verniciatura, nel colore _____ secondo tabelle RAL dovrà essere eseguita in base a quanto previsto dal marchio europeo "QUALICOAT".

LIMITI DI IMPIEGO

Il progettista o il serramentista, in fase di determinazione delle dimensioni massime dei serramenti dovrà considerare e valutare oltre alle dimensioni ed alle inerzie dei profilati, anche i fattori inerenti alla posa e alle caratteristiche meteorologiche, quali l'altezza dal suolo, l'esposizione alla pioggia e la velocità dei venti presenti nella zona. Per la conoscenza e l'utilizzo di questi dati, consigliamo di consultare e seguire quanto indicato sulle "Raccomandazioni UNCSAAL" elaborate sulla base delle norme UNI, UNI-EN ed UNI-CNR esistenti in merito.

DESCRIZIONE TECNICA SISTEMA DOGMA SLIM

DOGMA SLIM, é un sistema per la costruzione di serramenti a battente marcabili  ,rappresenta una delle punte di diamante dei nostri Sistemi in Alluminio a taglio termico.

La sezione particolarmente snella è dedicata a soluzioni di design per realizzare finestra luminose con prevalente superficie vetrata. Il taglio termico da 34 mm per il telaio e 30 mm per l'anta rendono questo sistema ideale sia per l'edilizia privata, sia per uffici e strutture dove è importante raggiungere elevato comfort termo-acustico e grande luminosità per gli ambienti.

DOGMA SLIM permette l'alloggiamento di vetri con camere di grande spessore o con veneziane interne.

Il sistema è completo sotto ogni aspetto: profilati, accessori e finiture superficiali.

Pertanto si presta alla realizzazione delle tipologie più utilizzate.

DOGMA SLIM utilizza accessori per camera europea o pista 16 int.9mm, che consentono un'ampia scelta di soluzioni e all'occorrenza facilità di manutenzione, garantendo all'utente finale la totale soddisfazione.

TIPO DI SISTEMA :	Sormonto interno - Complanare esterno
PROFILATI ESTRUSI :	Lega d'alluminio 6060 Al Mg 0.5, Si 0.4, Fe 0.2 secondo le norme UNI EN 573
STATO DI FORNITURA :	T6 secondo la norma UNI EN 515 (equivalente TA 16)
TOLLERANZE DIMENSIONALI E SPESSORI :	UNI EN 12020.2 e/o UNI EN 755-9
SISTEMA DI TENUTA ARIA, ACQUA E VENTO :	
FINESTRE E PORTEFINESTRE :	Giunto Aperto a camera europea e/o ferramenta perimetrale con guarnizione centrale
TAGLIO TERMICO :	Con barrette complanari in poliammide da mm 34-30
DIMENSIONI DEL SISTEMA :	Telaio fisso sezione mm 65 Telaio anta sezione mm 75 Inserimento vetri variabile tra 22 e 56 mm
ALTEZZA SEDE VETRO :	mm 22 - 15
INSERIMENTO VETRO :	Fermavetro sia rettangolare che arrotondato o sgusciato (aggancio a scatto,con molletta oppure a contrasto)
GUARNIZIONI :	In gomma sintetica, EPDM - TPE - GOMMA SILICONICA
CERTIFICAZIONI :	ISTEDIL di Guidonia (RM) Rapporto di Prova n. 597/2019 del 04.09.2019 Permeabilità all'aria (UNI EN 1026, UNI EN 12207): Classe 4 Tenuta all'acqua(UNI EN 1027, UNI EN 12208): Classe E1350 Resistenza al vento (UNI EN 12221, UNI EN 12210): Classe C4 Altri certificati del sistema sono a disposizione.
TRASMITTANZA TERMICA :	Uf variabile secondo la configurazione adottata, come da calcoli eseguiti da IRCCOS di Samarate (VA) nel pieno rispetto delle norme UNI EN 10077-1 e UNI EN 10077-2. Per certificati contattare l'Ufficio Tecnico.
MARCATURA CE :	Come previsto da norma UNI EN 14351-1+A1:2010 Cascading disponibile

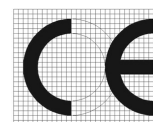

U_w SERRAMENTO CAMPIONE DOGMA

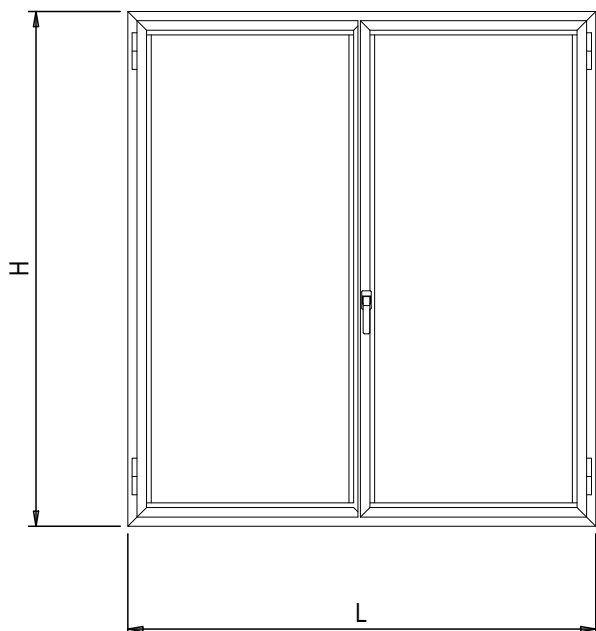

$$U_w = 1.30 \text{ W/m}^2\text{K}$$

VETRO DI $U_g = 1.0 \text{ W/m}^2\text{K}$ CERTIFICATO
CON CANALINA CALDA $\psi = 0.036 \text{ W/mK}$

L : 1535 mm

H : 1480 mm

Dimensioni ammesse per il calcolo U_w su serramento campione fino a 2.3 m² dalla norma UNI EN 14351-1 + A1:2010

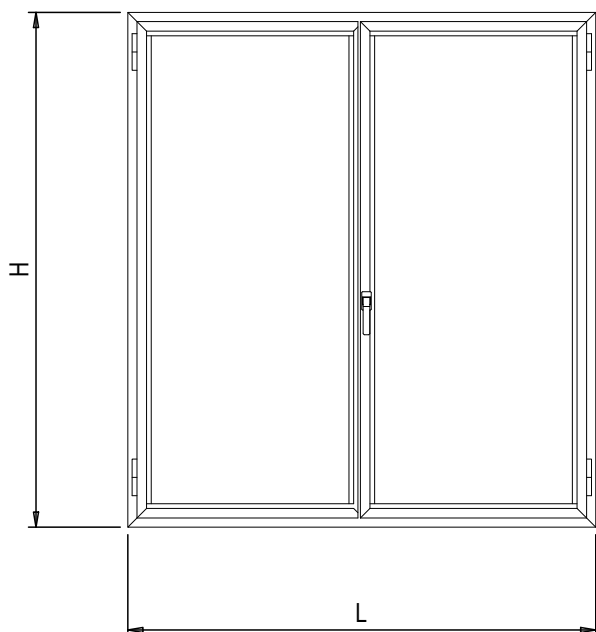

$$U_w = 1.00 \text{ W/m}^2\text{K}$$

VETRO DI $U_g = 0.6 \text{ W/m}^2\text{K}$ CERTIFICATO
CON CANALINA CALDA $\psi = 0.036 \text{ W/mK}$

L : 1535 mm

H : 1480 mm

Marcabili  come previsto da norma UNI EN 14351-1+A1:2010, cascading disponibile.

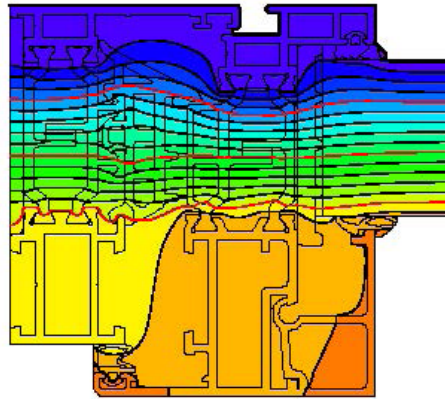

$$U_f = 1.7 \text{ W/m}^2\text{K}$$

CERTIFICATO IRcCOS
N° 1994-CRP-RP1890 del 02.09.2019

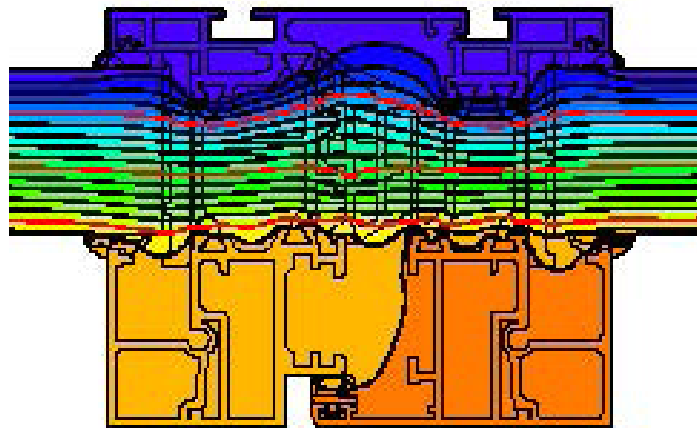

$$U_f = 1.8 \text{ W/m}^2\text{K}$$

CERTIFICATO IRcCOS
N° 1994-CRP-RP1890 del 02.09.2019



PERMEABILITA' ALL'ARIA
SECONDO NORME EN 1026 EN 12207

Classe ottenuta dalla finestra campione DOGMA SLIM	1	2	3	4
--	---	---	---	----------

LA CLASSE OTTENUTA DAL SERRAMENTO INDICA CHE ALLA PRESSIONE DI PROVA PARI A 600 PASCAL IL VOLUME D'ARIA FILTRATA ALL'INTERNO E' IL MINORE POSSIBILE. LA SCALA DI BEAUFORT DI CLASSIFICAZIONE DEL VENTO INDICA CHE 600 PASCAL CORRISPONDONO AD UN VENTO DI CIRCA 110km/h (TEMPESTA VIOLENTA).



TENUTA ALL'ACQUA
SECONDO NORME EN 1027 EN 12208

Classe ottenuta dalla finestra campione DOGMA SLIM	1A	2A	3A	4A	5A	6A	7A	9A	E750	E1350
--	----	----	----	----	----	----	----	----	------	--------------

LA CLASSE OTTENUTA DAL SERRAMENTO SOTTOPOSTO A TEST INDICA CHE NON SI SONO VERIFICATE INFILTRAZIONI D'ACQUA ALL'INTERNO FINO ALLA PRESSIONE DI 1350 PASCAL LA QUANTITA' D'ACQUA UTILIZZATA PER IL TEST E' QUELLA PREVISTA PER SERRAMENTI TOTALMENTE ESPOSTI (A)



RESISTENZA AL VENTO
SECONDO NORME EN 12211 EN 12210

Classe della pressione di prova	1	2	3	4	5
---------------------------------	---	---	---	----------	---

Classe di flessione ottenuta finestra campione DOGMA SLIM	A	B	C
---	---	---	----------

LA CLASSE C4 OTTENUTA DAL SERRAMENTO INDICA CHE ESSO, SOTTOPOSTO A 50 CICLI RIPETUTI DI PRESSIONE DI +800 E -800 PASCAL ED ALLA PRESSIONE DI SICUREZZA DI 2400 PASCAL, NON HA RIPORTATO ALCUN DANNO ALLA FUNZIONALITA'. INDICA INOLTRE CHE LA FRECCIA MASSIMA DI INFLESSIONE NON HA SUPERATO 1/300 DELL'ALTEZZA.

LIMITI DI IMPIEGO



LIMITI DI IMPIEGO FRECCIA MAX 1/200H / PRESSIONE MAX 1000Pa											
H/L	600	650	700	750	800	850	900	950	1000	1050	1100
1000											
1050											
1100											
1150											
1200											
1250											
1300											
1350											
1400											
1450											
1500											
1550											
1600											
1650											
1700											
1750											
1800											
1850											
1900											
1950											
2000											
2050											
2100											
2150											
2200											
2250											
2300											
2350											
2400											
2450											
2500											

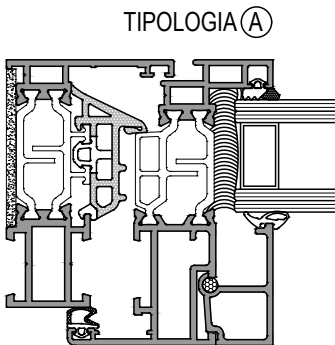
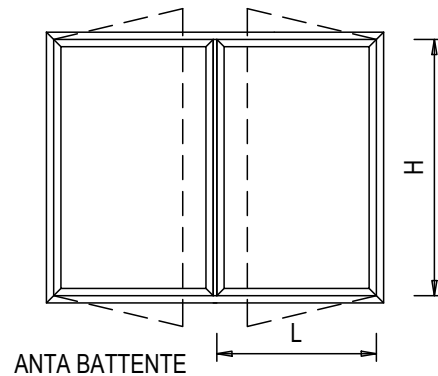
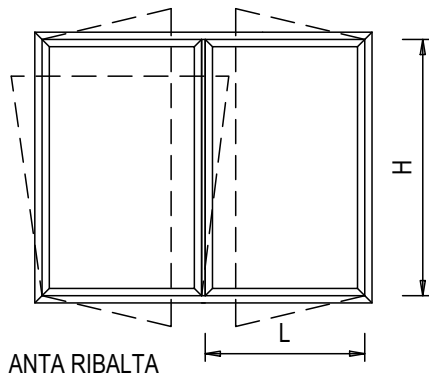

SIGILLARE PER CIRCA 100 mm IN PROSSIMITÀ DELLA MANIGLIA

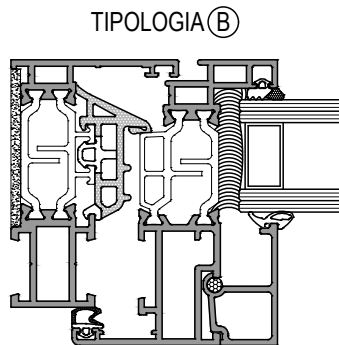

SIGILLARE PER CIRCA 100 mm IN PROSSIMITÀ DELLA MANIGLIA CERNIERE E PUNTI DI CHIUSURA

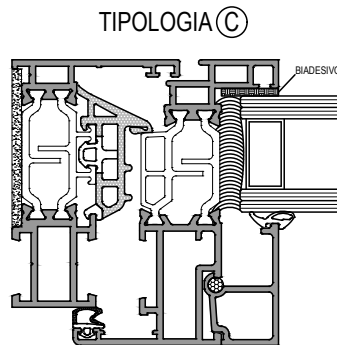

SIGILLARE PER CIRCA 100 mm IN PROSSIMITÀ DELLA MANIGLIA CERNIERE E PUNTI DI CHIUSURA

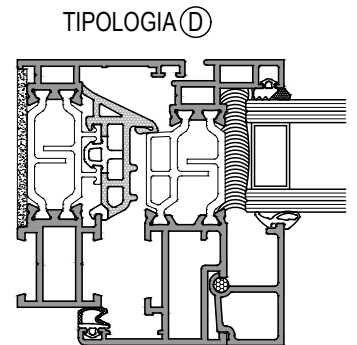

SIGILLARE PER TUTTO IL PERIMETRO LASCIANDO LIBERE LE ZONE DI AERAZIONE ANTA

INCOLLAGGIO STRUTTURALE

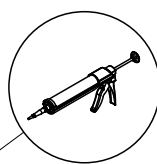

INCOLLAGGIO STRUTTURALE DA REALIZZARE PREFERIBILMENTE CON SIGILLANTE BICOMPONENTE PER ESEMPIO DOW CORNING 121 SGS O SIKA SIKASIL SG500 (ASSICURARSI CHE IL SILICONE SIA COMPATIBILE CON QUELLO USATO DAL VETRAIO)

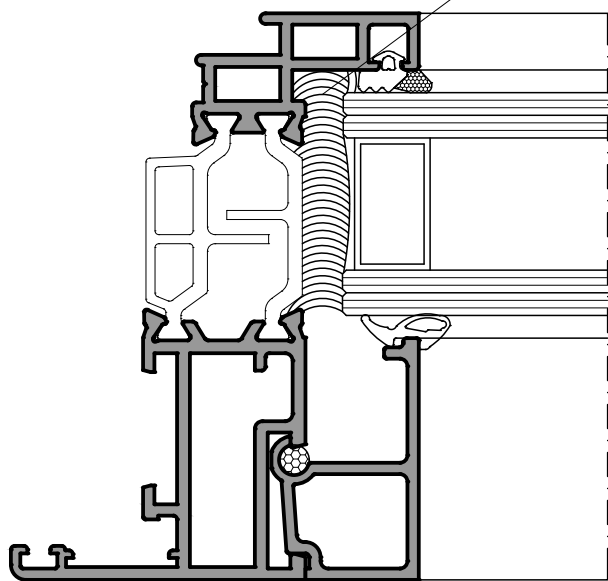

665M01

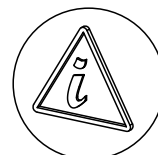

PER UN CORRETTO INCOLLAGGIO STRUTTURALE FARE RIFERIMENTO ALLE SCHEDE TECNICHE DEL PRODUTTORE.

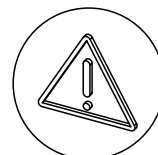

PER OTTENERE UNA PERFETTA GIUNZIONE ALL' ANGOLO È FONDAMENTALE CURARE IL POSIZIONAMENTO DEL PROFILATI SULLE TRONCATRICI.

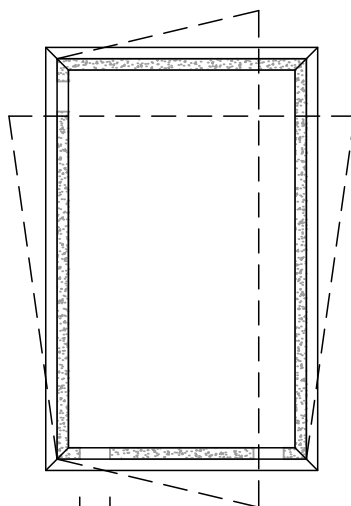

100

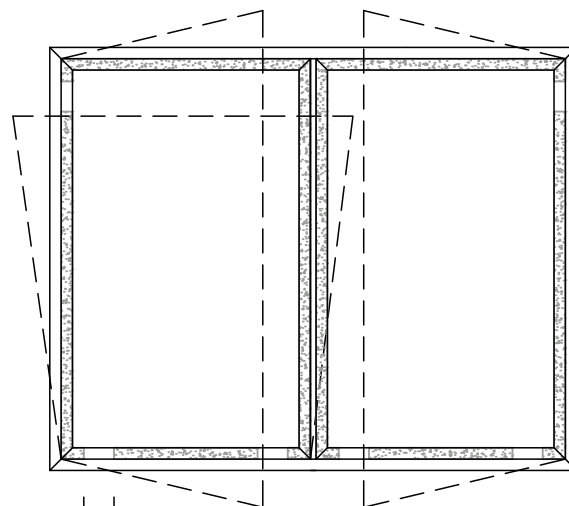

100



NON SIGILLARE PER CIRCA 100mm IN PROSSIMITÀ DELLA ASOLE DI AERAZIONE ANTA

INCOLLAGGIO MEDIANTE BIADESIVO

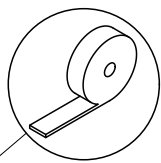
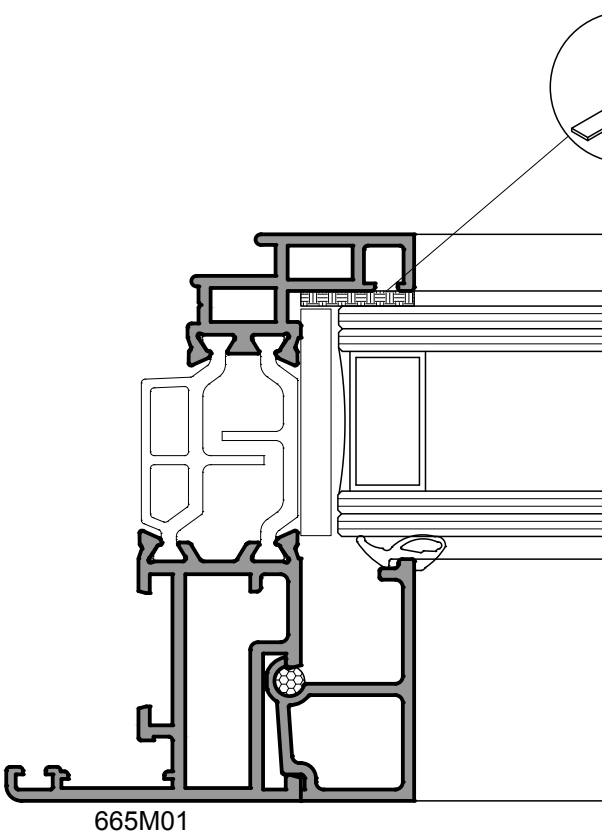

INCOLLAGGIO MEDIANTE BIADESIVO
PER ESEMPIO 3M VHB 4918

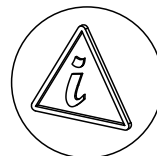
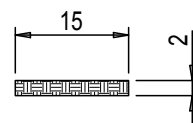

PER UN CORRETTO INCOLLAGGIO FARE RIFERIMENTO ALLE
SCHEDE TECNICHE DEL PRODUTTORE.



PER OTTENERE UNA PERFETTA GIUNZIONE ALL' ANGOLO È
FONDAMENTALE CURARE IL POSIZIONAMENTO DEL
PROFILATI SULLE TRONCATRICI.

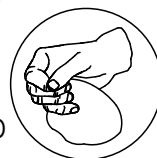
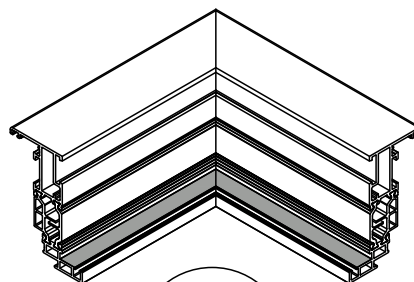

PULIRE LA SUPERFICIE
LUNGO TUTTO IL PERIMETRO

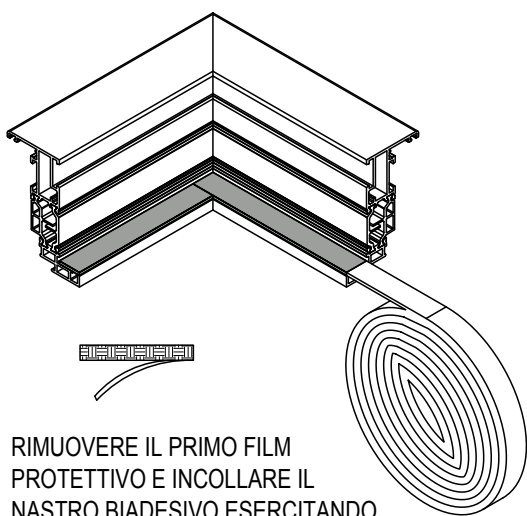

RIMUOVERE IL PRIMO FILM
PROTETTIVO E INCOLLARE IL
NASTRO BIADESIVO ESERCITANDO
PRESSIONE CON UN RULLO.
UNIRE A 90° AGLI ANGOLI.

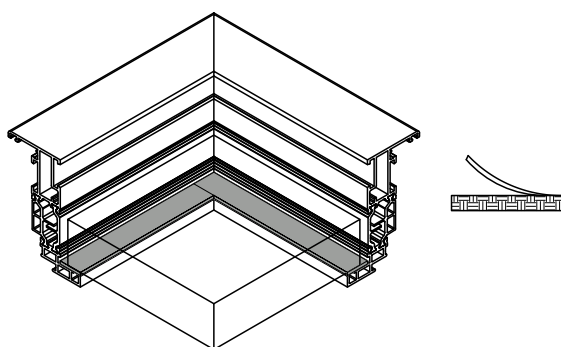

POSIZIONARE I Distanziatori PER LO SPESSORAMENTO DEL VETRO.
RIMUOVERE IL SECONDO FILM PROTETTIVO E APPLICARE IL VETRO IN
MANIERA PRECISA ESERCITANDO UNA LEGGERA PRESSIONE.
ATTENDERE CIRCA 24 ORE PER OTTENERE UNA CORRETTA ADESIONE.

TIPOLOGIE REALIZZABILI

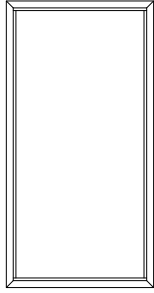

FISSO

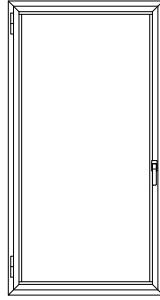

1 ANTA APERTURA INTERNA



VASISTAS

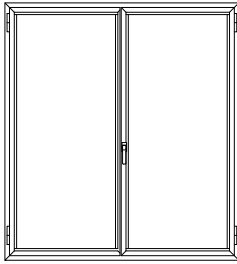

2 ANTE APERTURA INTERNA Z - T

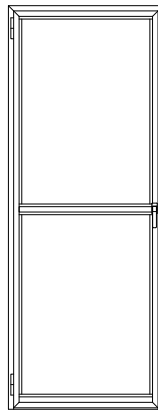

PORTA-BALCONE 1 ANTA APERTURA INTERNA

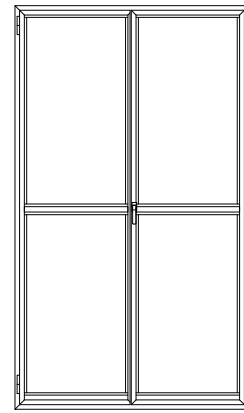

PORTA-BALCONE 2 ANTE APERTURA INTERNA Z - T



- Elenco Accessori **A**
- Elenco Guarnizioni **G**
- Elenco Attrezzature **A**

LE IMMAGINI SONO INDICATIVE E NON IMPEGNATIVE

SAGOMA	ARTICOLO	MATERIALE / COLORE	DESCRIZIONE
	G101	NYLON	CAPPETTA PER DRENAGGIO ACQUA
		VARI	SCATOLA DA : 1000 Pz.
	G112	ACCIAIO	SQUADRETTA ALLINEAMENTO ALETTE
		INOX	SCATOLA DA : 1000 Pz.
	G199	ALLUMINIO	CAVALLOTTO PER TRAVERSO ART. 665020
		GREZZO	SCATOLA DA : 100 Pz.
	G218	ALLUMINIO	SPINA DIAMETRO 8 PER CAVALLOTTO INTERNO ART. G199
		GREZZO	SCATOLA DA : 400 Pz.
	G269	ALLUMINIO	SQUADRETTA DI ALLINEAMENTO DA 14.4 x 1 mm PER ANTE/TELAJ
		GREZZO	SCATOLA DA : 50 Pz.
	G501N	ALLUMINIO	SQUADRETTA DI ALLINEAMENTO A CAMME PER TELAI E CAVALLOTTO PER TRAVERSI SU TELAI FISSI
		GREZZO	SCATOLA DA : 250 Pz.

SAGOMA	ARTICOLO	MATERIALE / COLORE	DESCRIZIONE
	G220	ALLUMINIO	SQUADRETTA DI ALLINEAMENTO COPRIFILI 40113 - 40114
		GREZZO	SCATOLA DA : 100 Pz.
	G255	NYLON	SQUADRETTA DI ALLINEAMENTO COPRIFILO 40245
		NERO	SCATOLA DA : 50 Pz.
	GT118	NYLON	TAPPI PER GOCCIOLATOIO UNIVERSALE ART. 40269
		NERO	SCATOLA DA : 25 Pz.
	GT134	NYLON	CLIP AGGANCIAMENTO FERMAVETRI
		BIANCO	SCATOLA DA : 200 Pz.
	TA089	NYLON	REGOLO TELAIO
		NERO	SCATOLA DA : 200 Pz.
	TA091	NYLON	REGOLO TELAIO
		NERO	SCATOLA DA : 200 Pz.

SAGOMA	ARTICOLO	MATERIALE / COLORE	DESCRIZIONE
	TS073	ALLUMINIO	CAVALLOTTO ESTERNO PER TRAVERSO TELAIO
		GREZZO	SCATOLA DA : 100 Pz.
	TS091	ALLUMINIO	CAVALLOTTO ESTERNO PER TRAVERSO ANTA
		GREZZO	SCATOLA DA : 10 Pz.
	TS090	ALLUMINIO	CAVALLOTTO INTERNO PER TRAVERSO ANTA
		GREZZO	SCATOLA DA : 10 Pz.
	TS204	ALLUMINIO	SQUADRETTA A CIANFRINARE/SPINARE PER TELAI
		GREZZO	SCATOLA DA : 300 Pz.
	TS205	ALLUMINIO	SQUADRETTA A CIANFRINARE/SPINARE PER ANTE
		GREZZO	SCATOLA DA : 300 Pz.
	TS206	ALLUMINIO	SQUADRETTA A CIANFRINARE PER TELAI E ANTE
		GREZZO	SCATOLA DA : 300 Pz.

SAGOMA	ARTICOLO	MATERIALE / COLORE	DESCRIZIONE
	S810	ACCIAIO	SPINA D8 PER SQUADRETTE INTERNE TELAI E ANTE SCATOLA DA : 400 Pz.
		INOX	
	S3001	ACCIAIO	SPINA D3 PER SQUADRETTE ESTERNE TELAI E ANTE SCATOLA DA : 400 Pz.
		INOX	
	G266	ALLIMINIO	SPINA D3 PER SQUADRETTE ESTERNE TELAI E ANTE SCATOLA DA : 400 Pz.
		GREZZO	
	TT067	NYLON	TAPPO ANTERIORE PER SOLUZIONE TZ SCATOLA DA : 24 Pz.
		NERO	
	TT069	NYLON	TAPPO POSTERIORE PER SOLUZIONE TZ PISTA 16 ART.665M03 - 665M04 SCATOLA DA : 24 Pz.
		NERO	
	TT041	NYLON	TAPPO POSTERIORE PER SOLUZIONE TZ CAMERA EUROPEA ART.665M01 - 665M02 SCATOLA DA : 24 Pz.
		NERO	

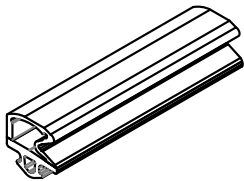
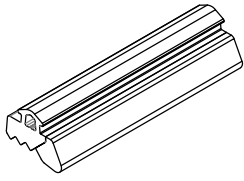
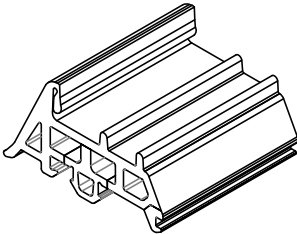
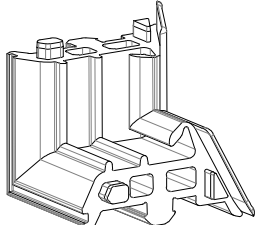
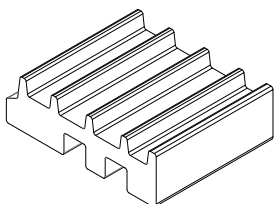
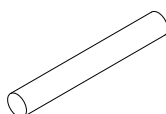
SAGOMA	ARTICOLO	MATERIALE / COLORE	DESCRIZIONE
	TG031	E.P.D.M. + ESPANSO	GUARNIZIONE DI BATTUTA INTERNA SCATOLA DA : 200 ml
		NERO	
	TG032	E.P.D.M. + ESPANSO	GUARNIZIONE CINGIVETRO ESTERNA DA 3 mm SCATOLA DA : 250 ml
		NERO	
	TG175	E.P.D.M. + ESPANSO	GUARNIZIONE DI TENUTA CENTRALE IN DOPPIA DENSITÀ SCATOLA DA : 50 ml
		NERO	
	TG176	E.P.D.M.	ANGOLO VULCANIZZATO PER GUARNIZIONE TG075 APERTURA INTERNA SCATOLA DA : 40 Pz.
		NERO	
	TG300	PEX	GUARNIZIONE SOTTOVETRO ISOLANTE PER FISSI SCATOLA DA : 100 ml
		GRIGIO	
	TG174	E.P.D.M.	GUARNIZIONE PER FERMAVETRO ROTOLO DA : 100 ml.
		NERO	

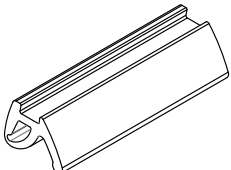
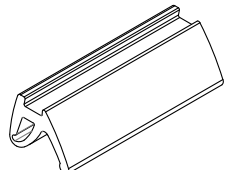
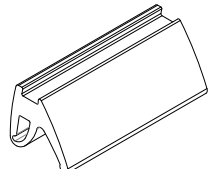
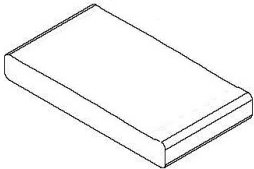
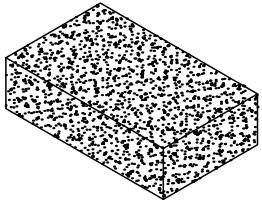
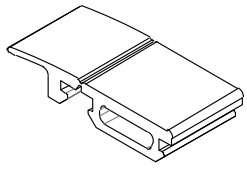
SAGOMA	ARTICOLO	MATERIALE / COLORE	DESCRIZIONE
	TG304	E.P.D.M.	GUARNIZIONE INTERNA CINGIVETRO DA 3 mm A 4 mm SCATOLA DA : 600 ml
		NERO	
	TG305	E.P.D.M.	GUARNIZIONE INTERNA CINGIVETRO DA 5 mm A 6 mm SCATOLA DA : 320 ml
		NERO	
	TG306	E.P.D.M.	GUARNIZIONE INTERNA CINGIVETRO DA 7 mm A 8 mm SCATOLA DA : 200 ml
		NERO	
	TG307	PEX	GUARNIZIONE SOTTOVETRO ISOLANTE PER ANTE SCATOLA DA : 150 ml.
		GRIGIO	
	Z119	POLIURETANO	GUARNIZIONE ISOLANTE TELAI A MURO SCATOLA DA : 10 ml
		GRIGIO	
	TG005	E.P.D.M.	COPRICAVA A SCATTO PER CAVA CAMERA EUROPEA SCATOLA DA : 75 ml
		NERO	

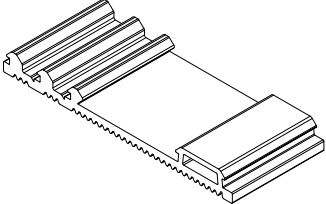
SAGOMA	ARTICOLO	MATERIALE / COLORE	DESCRIZIONE
	TG302	E.P.D.M.	GUARNIZIONE INFERIORE ISOLAMENTO SOGLIA SCATOLA DA : 30 ml
		NERO	

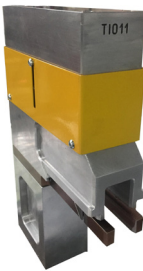
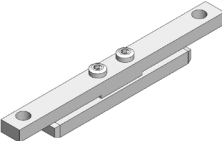
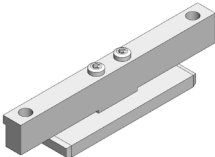
SAGOMA	ARTICOLO	MATERIALE / COLORE	DESCRIZIONE
	TI015	MISCELLANEA UTILIZZARE CON UNITÀ DI SPINTA DA AQUISTARE SEPARATAMENTE	TRANCIANTE FORO D.8 mm PER SQUADRETTE INTERNE PER TELAI E ANTE SCATOLA DA : 1 Pz.
	GA119	MISCELLANEA	DIMA PER FORO D.8mm PER SQUADRETTE INTERNE TELAJ SCATOLA DA : NO STOCK
	GA118	MISCELLANEA	DIMA PER FORO D.8mm PER SQUADRETTE INTERNE ANTE CAMERA EUROPEA SCATOLA DA : NO STOCK
	GA120	MISCELLANEA	DIMA PER FORO D.8mm PER SQUADRETTE INTERNE ANTE PISTA 16 SCATOLA DA : NO STOCK
	GA065	MISCELLANEA	CIANFRINATRICE MANUALE (UTILIZZARE COLTELLI DA 3mm) SCATOLA DA : 1 Pz.
	GA117	MISCELLANEA	MARTELLO PNEUMATICO PER SPINATURA SCATOLA DA : 1 Pz.



SAGOMA	ARTICOLO	MATERIALE / COLORE	DESCRIZIONE
	GA112	ALLUMINIO	DIMA FORO 3mm PER CAVALLOTTO ESTERNO TRAVERSI SCATOLA DA : 1 Pz
		GREZZO	
	GFDTZ1	ACCIAIO	GRUPPO FRESA PER LAVORAZIONE ANTA Z CE E P16 SCATOLA DA : NO MAGAZZINO
		GREZZO	
	GFDTZ3	ACCIAIO	GRUPPO FRESA PER LAVORAZIONE ANTA T CE SCATOLA DA : NO MAGAZZINO
		GREZZO	
	GFDTZ4	ACCIAIO	GRUPPO FRESA PER LAVORAZIONE ANTA T P16 SCATOLA DA : NO MAGAZZINO
		GREZZO	



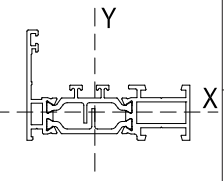
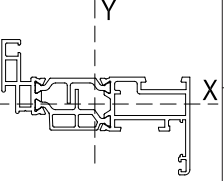
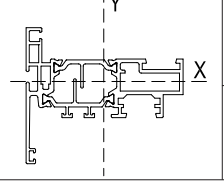
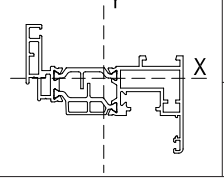
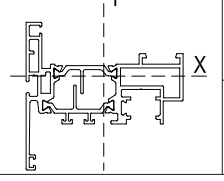
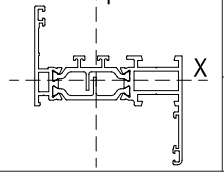
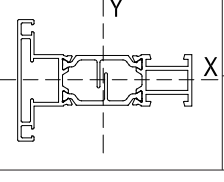
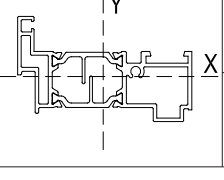
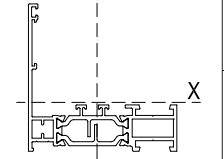

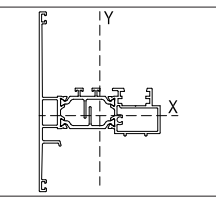
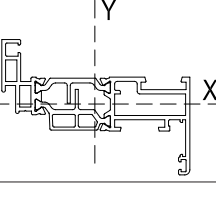
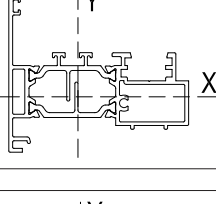
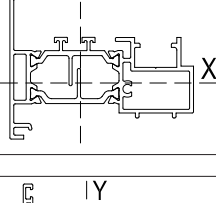
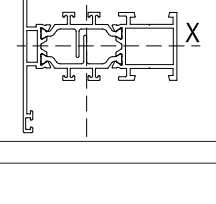
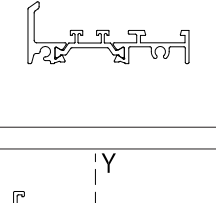
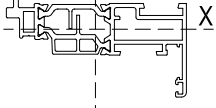

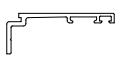
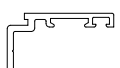
Profilati ed Inerzie

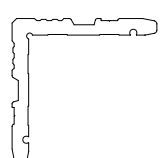
 SAGOMA	ARTICOLO	INERZIA	MODULO	DESCRIZIONE
	PESO (Kg/m)	cm ⁴	cm ³	
	665M00	J_x 2.8	W_x 0.7	TELAIO L (PAG. 4.3)
	1.113	J_y 16.1	W_y 4.2	
	665M01	J_x 4.2	W_x 1.4	ANTA Z CAMERA AUROPEA (PAG. 4.4)
	1.334	J_y 23.8	W_y 6.3	
	665M02	J_x 7.0	W_x 2.1	ANTA T CAMERA EUROPEA (PAG. 4.4)
	1.629	J_y 27.3	W_y 6.3	
	665M03	J_x 6.2	W_x 2.0	ANTA Z PISTA 16 (PAG. 4.5)
	1.562	J_y 28.0	W_y 7.3	
	665M04	J_x 9.2	W_x 2.4	ANTA T PISTA 16 (PAG. 4.5)
	1.785	J_y 30.0	W_y 6.7	
	665M05	J_x 5.6	W_x 1.4	TELAIO Z (PAG. 4.3)
	1.247	J_y 20.3	W_y 5.6	
	665M07	J_x 4.9	W_x 2.1	TRAVERSO PER ANTA (PAG. 4.6)
	1.334	J_y 23.8	W_y 5.6	
	665M08	J_x 4.9	W_x 2.1	ZOCCOLO RIPORTATO PER ANTA (PAG. 4.7)
	1.363	J_y 21.7	W_y 5.6	
	665M09	J_x 10.5	W_x 2.1	TELAIO FISSO L PER ANTA A SCOMPARSA (PAG. 4.9)
	1.297	J_y 21.7	W_y 5.6	

 SAGOMA	ARTICOLO	INERZIA	MODULO	DESCRIZIONE
	PESO (Kg/m)	cm ⁴	cm ³	
	665M10	<i>J_x</i> 23.1	<i>W_x</i> 3.5	RIPORTO CENTRALE PER ANTA A SCOMPARSA (PAG. 4.10)
	1.733	<i>J_y</i> 32.2	<i>W_y</i> 7	
	665M11	<i>J_x</i> 13.3	<i>W_x</i> 2.1	TELAIO FISSO Z PER ANTA A SCOMPARSA (PAG. 4.9)
	1.434	<i>J_y</i> 27.3	<i>W_y</i> 7	
	665003	<i>J_x</i> 6.0	<i>W_x</i> 1.7	RIPORTO CENTRALE CAMERA EUROPEA (PAG. 4.8)
	1.340	<i>J_y</i> 21.2	<i>W_y</i> 5.1	
	665018	<i>J_x</i> 6.1	<i>W_x</i> 1.7	RIPORTO CENTRALE PISTA 16 (PAG. 4.8)
	1.348	<i>J_y</i> 21.3	<i>W_y</i> 5.1	
	665020	<i>J_x</i> 6.8	<i>W_x</i> 1.9	TRAVERSO CON CAVALOTTI TUBOLARITÀ STANDARD (PAG. 4.6)
	1.294	<i>J_y</i> 18.5	<i>W_y</i> 4.9	
	665087	<i>J_x</i>	<i>W_x</i>	SOGLIA RIBASSATA (PAG. 4.7)
	0.766	<i>J_y</i>	<i>W_y</i>	
	665107	<i>J_x</i> 3.5	<i>W_x</i> 1.4	ANTA Z LINEA FERRO CAMERA AUROPEA (PAG. 4.11)
	1.302	<i>J_y</i> 23.1	<i>W_y</i> 6.3	

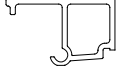
 SAGOMA	ARTICOLO	INERZIA	MODULO	DESCRIZIONE
	<i>PESO (Kg/m)</i>	<i>cm⁴</i>	<i>cm³</i>	
	665276	<i>J_x</i>	<i>W_x</i>	COPRIFILO A MURO 40 MM (PAG. 4.13)
	0.306	<i>J_y</i>	<i>W_y</i>	
	665277	<i>J_x</i>	<i>W_x</i>	COPRIFILO A MURO 26 MM (PAG. 4.13)
	0.244	<i>J_y</i>	<i>W_y</i>	
	665278	<i>J_x</i>	<i>W_x</i>	COPRIFILO A MURO 70 MM (PAG. 4.13)
	0.475	<i>J_y</i>	<i>W_y</i>	
	40269	<i>J_x</i>	<i>W_x</i>	PROFILATO GOCCIOLATOIO (PAG. 4.13)
	0.141	<i>J_y</i>	<i>W_y</i>	
	665331	<i>J_x</i>	<i>W_x</i>	PROFILATO PER SQUADRETTA
	2.438	<i>J_y</i>	<i>W_y</i>	

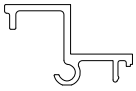
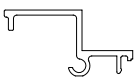

 SAGOMA	ARTICOLO	INERZIA	MODULO	DESCRIZIONE
	<i>PESO (Kg/m)</i>	<i>cm⁴</i>	<i>cm³</i>	
	665332	<i>J_x</i>	<i>W_x</i>	FERMAVETRO PER ANTA DA 32 mm (PAG. 4.14)
	0.343	<i>J_y</i>	<i>W_y</i>	
	665359	<i>J_x</i>	<i>W_x</i>	FERMAVETRO PER ANTA DA 24 mm (PAG. 4.14)
	0.311	<i>J_y</i>	<i>W_y</i>	
	665360	<i>J_x</i>	<i>W_x</i>	FERMAVETRO PER ANTA DA 15 mm (PAG. 4.14)
	0.259	<i>J_y</i>	<i>W_y</i>	
	665414	<i>J_x</i>	<i>W_x</i>	FERMAVETRO LINEA FERRO PER ANTA DA 31 mm (PAG. 4.12)
	0.226	<i>J_y</i>	<i>W_y</i>	
	665415	<i>J_x</i>	<i>W_x</i>	FERMAVETRO LINEA FERRO PER ANTA DA 14.5 mm (PAG. 4.12)
	0.264	<i>J_y</i>	<i>W_y</i>	
	665420	<i>J_x</i>	<i>W_x</i>	FERMAVETRO LINEA FERRO PER ANTA DA 38 mm (PAG. 4.12)
	0.293	<i>J_y</i>	<i>W_y</i>	



 SAGOMA	ARTICOLO	INERZIA	MODULO	DESCRIZIONE
	PESO (Kg/m)	cm ⁴	cm ³	
	40007	<i>J_x</i>	<i>W_x</i>	FERMAVETRO PIANO DA 25,5 MM (PAG. 4.15)
	0.318	<i>J_y</i>	<i>W_y</i>	
	40029	<i>J_x</i>	<i>W_x</i>	FERMAVETRO PIANO DA 20,5 MM (PAG. 4.15)
	0.283	<i>J_y</i>	<i>W_y</i>	
	40030	<i>J_x</i>	<i>W_x</i>	FERMAVETRO PIANO DA 13,5 MM (PAG. 4.15)
	0.263	<i>J_y</i>	<i>W_y</i>	
	40037	<i>J_x</i>	<i>W_x</i>	FERMAVETRO PIANO DA 35,5 MM (PAG. 4.16)
	0.359	<i>J_y</i>	<i>W_y</i>	
	40039	<i>J_x</i>	<i>W_x</i>	FERMAVETRO PIANO DA 30,5 MM (PAG. 4.16)
	0.339	<i>J_y</i>	<i>W_y</i>	
	40077	<i>J_x</i>	<i>W_x</i>	FERMAVETRO ARROTONDATO DA 35,5 MM (PAG. 4.21)
	0.352	<i>J_y</i>	<i>W_y</i>	
	40078	<i>J_x</i>	<i>W_x</i>	FERMAVETRO ARROTONDATO DA 33 MM (PAG. 4.20)
	0.342	<i>J_y</i>	<i>W_y</i>	
	40079	<i>J_x</i>	<i>W_x</i>	FERMAVETRO ARROTONDATO DA 30,5 MM (PAG. 4.20)
	0.332	<i>J_y</i>	<i>W_y</i>	
	40080	<i>J_x</i>	<i>W_x</i>	FERMAVETRO ARROTONDATO DA 25,5 MM (PAG. 4.20)
	0.312	<i>J_y</i>	<i>W_y</i>	



 SAGOMA	ARTICOLO	INERZIA	MODULO	DESCRIZIONE
	PESO (Kg/m)	cm⁴	cm³	
	40081	<i>J_x</i>	<i>W_x</i>	FERMAVETRO ARROTONDATO DA 23,5 MM (PAG. 4.20)
	0.293	<i>J_y</i>	<i>W_y</i>	
	40082	<i>J_x</i>	<i>W_x</i>	FERMAVETRO ARROTONDATO DA 20,5 MM (PAG. 4.20)
	0.274	<i>J_y</i>	<i>W_y</i>	
	40083	<i>J_x</i>	<i>W_x</i>	FERMAVETRO ARROTONDATO DA 13,5 MM (PAG. 4.20)
	0.252	<i>J_y</i>	<i>W_y</i>	
	40085	<i>J_x</i>	<i>W_x</i>	FERMAVETRO PIANO DA 5,5 MM (PAG. 4.15)
	0.210	<i>J_y</i>	<i>W_y</i>	
	40086	<i>J_x</i>	<i>W_x</i>	FERMAPANNELLO DA 2 MM (PAG. 4.15)
	0.178	<i>J_y</i>	<i>W_y</i>	
	40087	<i>J_x</i>	<i>W_x</i>	FERMAVETRO PIANO DA 23,5 MM (PAG. 4.15)
	0.303	<i>J_y</i>	<i>W_y</i>	
	40089	<i>J_x</i>	<i>W_x</i>	FERMAVETRO CON CLIP DA 35,5 MM (PAG. 4.18)
	0.348	<i>J_y</i>	<i>W_y</i>	
	40090	<i>J_x</i>	<i>W_x</i>	FERMAVETRO CON CLIP DA 33 MM (PAG. 4.18)
	0.336	<i>J_y</i>	<i>W_y</i>	
	40091	<i>J_x</i>	<i>W_x</i>	FERMAVETRO CON CLIP DA 30,5 MM (PAG. 4.18)
	0.324	<i>J_y</i>	<i>W_y</i>	

Profilati ed Inerzie

 SAGOMA	ARTICOLO	INERZIA	MODULO	DESCRIZIONE
	PESO (Kg/m)	cm ⁴	cm ³	
	40092	<i>J_x</i>	<i>W_x</i>	FERMAVETRO CON CLIP DA 25,5 MM (PAG. 4.17)
	0.291	<i>J_y</i>	<i>W_y</i>	
	40093	<i>J_x</i>	<i>W_x</i>	FERMAVETRO CON CLIP DA 23,5 MM (PAG. 4.17)
	0.282	<i>J_y</i>	<i>W_y</i>	
	40094	<i>J_x</i>	<i>W_x</i>	FERMAVETRO CON CLIP DA 20,5 MM (PAG. 4.17)
	0.268	<i>J_y</i>	<i>W_y</i>	
	40095	<i>J_x</i>	<i>W_x</i>	FERMAVETRO CON CLIP DA 13,5 MM (PAG. 4.17)
	0.236	<i>J_y</i>	<i>W_y</i>	
	40096	<i>J_x</i>	<i>W_x</i>	FERMAVETRO CON CLIP DA 10,5 MM (PAG. 4.17)
	0.221	<i>J_y</i>	<i>W_y</i>	
	40097	<i>J_x</i>	<i>W_x</i>	FERMAVETRO CON CLIP DA 5,5 MM (PAG. 4.17)
	0.199	<i>J_y</i>	<i>W_y</i>	
	40098	<i>J_x</i>	<i>W_x</i>	FERMAPANNELLO CON CLIP DA 2 MM (PAG. 4.17)
	0.169	<i>J_y</i>	<i>W_y</i>	
	40111	<i>J_x</i>	<i>W_x</i>	FERMAVETRO PIANO DA 33 MM (PAG. 4.16)
	0.347	<i>J_y</i>	<i>W_y</i>	
	40185	<i>J_x</i>	<i>W_x</i>	FERMAVETRO PIANO DA 17,5 MM (PAG. 4.15)
	0.280	<i>J_y</i>	<i>W_y</i>	

 SAGOMA	ARTICOLO	INERZIA	MODULO	DESCRIZIONE
	PESO (Kg/m)	cm ⁴	cm ³	
	40186	<i>J_x</i>	<i>W_x</i>	FERMAVETRO ARROTONDATO DA 17,5 MM (PAG. 4.20)
	0.272	<i>J_y</i>	<i>W_y</i>	
	40187	<i>J_x</i>	<i>W_x</i>	FERMAVETRO CON CLIP DA 17,5 MM (PAG. 4.17)
	0.254	<i>J_y</i>	<i>W_y</i>	
	40216	<i>J_x</i>	<i>W_x</i>	FERMAVETRO ARROTONDATO DA 15 MM (PAG. 4.20)
	0.259	<i>J_y</i>	<i>W_y</i>	
	40217	<i>J_x</i>	<i>W_x</i>	FERMAVETRO PIANO DA 15 MM (PAG. 4.15)
	0.267	<i>J_y</i>	<i>W_y</i>	
	40218	<i>J_x</i>	<i>W_x</i>	FERMAVETRO CON CLIP DA 15 MM (PAG. 4.17)
	0.243	<i>J_y</i>	<i>W_y</i>	
	40225	<i>J_x</i>	<i>W_x</i>	FERMAVETRO ARROTONDATO CON SCURETTO DA 13,5 MM (PAG. 4.21)
	0.261	<i>J_y</i>	<i>W_y</i>	
	40226	<i>J_x</i>	<i>W_x</i>	FERMAVETRO ARROTONDATO CON SCURETTO DA 20,5 MM (PAG. 4.21)
	0.270	<i>J_y</i>	<i>W_y</i>	
	40227	<i>J_x</i>	<i>W_x</i>	FERMAVETRO ARROTONDATO CON SCURETTO DA 30,5 MM (PAG. 4.21)
	0.341	<i>J_y</i>	<i>W_y</i>	
	40228	<i>J_x</i>	<i>W_x</i>	FERMAVETRO ARROTONDATO CON SCURETTO DA 17,5 MM (PAG. 4.21)
	0.278	<i>J_y</i>	<i>W_y</i>	

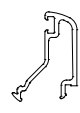
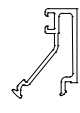
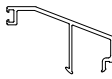
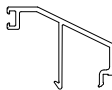
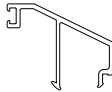
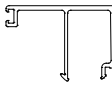
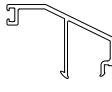
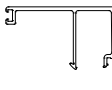
 SAGOMA	ARTICOLO	INERZIA	MODULO	DESCRIZIONE
	PESO (Kg/m)	cm ⁴	cm ³	
	40247	<i>J_x</i>	<i>W_x</i>	FERMAVETRO ARROTONDATO DA 9,5 MM (PAG. 4.20)
	0.229	<i>J_y</i>	<i>W_y</i>	
	40249	<i>J_x</i>	<i>W_x</i>	FERMAVETRO PIANO DA 9,5 MM (PAG. 4.15)
	0.242	<i>J_y</i>	<i>W_y</i>	
	40261	<i>J_x</i>	<i>W_x</i>	FERMAVETRO DESIGN DA 42.5 MM (PAG. 4.22)
	0.327	<i>J_y</i>	<i>W_y</i>	
	40262	<i>J_x</i>	<i>W_x</i>	FERMAVETRO DESIGN DA 34.5 MM (PAG. 4.22)
	0.302	<i>J_y</i>	<i>W_y</i>	
	40274	<i>J_x</i>	<i>W_x</i>	FERMAVETRO DESIGN DA 33 MM (PAG. 4.22)
	0.298	<i>J_y</i>	<i>W_y</i>	
	40275	<i>J_x</i>	<i>W_x</i>	FERMAVETRO PIANO DA 38.5 MM (PAG. 4.16)
	0.379	<i>J_y</i>	<i>W_y</i>	
	40276	<i>J_x</i>	<i>W_x</i>	FERMAVETRO DESIGN DA 38.5 MM (PAG. 4.22)
	0.330	<i>J_y</i>	<i>W_y</i>	
	40277	<i>J_x</i>	<i>W_x</i>	FERMAVETRO PIANO DA 46.5 MM (PAG. 4.16)
	0.414	<i>J_y</i>	<i>W_y</i>	
	40278	<i>J_x</i>	<i>W_x</i>	FERMAVETRO DESIGN DA 46.5 MM (PAG. 4.22)
	0.357	<i>J_y</i>	<i>W_y</i>	

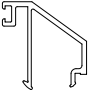
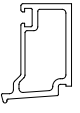
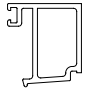
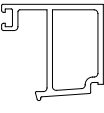
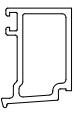
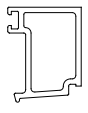
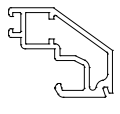
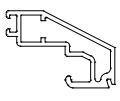
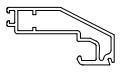

 SAGOMA	ARTICOLO	INERZIA	MODULO	DESCRIZIONE
	PESO (Kg/m)	cm ⁴	cm ³	
	40316	<i>J_x</i>	<i>W_x</i>	FERMAVETRO DESIGN DA 25.5 MM (PAG. 4.22)
	0.283	<i>J_y</i>	<i>W_y</i>	
	40327	<i>J_x</i>	<i>W_x</i>	FERMAVETRO TUBOLARE DA 13.5 MM (PAG. 4.19)
	0.311	<i>J_y</i>	<i>W_y</i>	
	40328	<i>J_x</i>	<i>W_x</i>	FERMAVETRO TUBOLARE DA 23.5 MM (PAG. 4.19)
	0.425	<i>J_y</i>	<i>W_y</i>	
	40329	<i>J_x</i>	<i>W_x</i>	FERMAVETRO DESIGN DA 28 MM CON CLIP (PAG. 4.19)
	0.405	<i>J_y</i>	<i>W_y</i>	
	41258	<i>J_x</i>	<i>W_x</i>	FERMAVETRO TUBOLARE DA 17.5 MM (PAG. 4.19)
	0.342	<i>J_y</i>	<i>W_y</i>	
	41259	<i>J_x</i>	<i>W_x</i>	FERMAVETRO TUBOLARE DA 20.5 MM (PAG. 4.19)
	0.359	<i>J_y</i>	<i>W_y</i>	
	72501	<i>J_x</i>	<i>W_x</i>	FERMAVETRO DESIGN DA 25.5 MM CON CLIP (PAG. 4.23)
	0.331	<i>J_y</i>	<i>W_y</i>	
	72502	<i>J_x</i>	<i>W_x</i>	FERMAVETRO DESIGN DA 31 MM CON CLIP (PAG. 4.23)
	0.364	<i>J_y</i>	<i>W_y</i>	
	72503	<i>J_x</i>	<i>W_x</i>	FERMAVETRO DESIGN DA 41 MM CON CLIP (PAG. 4.23)
	0.428	<i>J_y</i>	<i>W_y</i>	

 SAGOMA	ARTICOLO	INERZIA	MODULO	DESCRIZIONE
	PESO (Kg/m)	cm ⁴	cm ³	
	72504	<i>J_x</i>	<i>W_x</i>	FERMAVETRO DESIGN DA 47.5 MM CON CLIP (PAG. 4.23)
	0.492	<i>J_y</i>	<i>W_y</i>	
	72505	<i>J_x</i>	<i>W_x</i>	FERMAVETRO PIANO DA 41 MM (PAG. 4.16)
	0.392	<i>J_y</i>	<i>W_y</i>	
	72506	<i>J_x</i>	<i>W_x</i>	FERMAVETRO PIANO DA 47.5 MM (PAG. 4.16)
	0.420	<i>J_y</i>	<i>W_y</i>	
	72507	<i>J_x</i>	<i>W_x</i>	FERMAVETRO ARROTONDATO DA 41 MM (PAG. 4.20)
	0.380	<i>J_y</i>	<i>W_y</i>	
	72508	<i>J_x</i>	<i>W_x</i>	FERMAVETRO ARROTONDATO DA 45.5 MM (PAG. 4.20)
	0.416	<i>J_y</i>	<i>W_y</i>	
	72509	<i>J_x</i>	<i>W_x</i>	FERMAVETRO DESIGN DA 34 MM CON CLIP (PAG. 4.23)
	0.382	<i>J_y</i>	<i>W_y</i>	
	72512	<i>J_x</i>	<i>W_x</i>	FERMAVETRO DESIGN DA 28 MM CON CLIP (PAG. 4.23)
	0.348	<i>J_y</i>	<i>W_y</i>	
	72519	<i>J_x</i>	<i>W_x</i>	FERMAVETRO DESIGN DA 20 MM CON CLIP (PAG. 4.23)
	0.303	<i>J_y</i>	<i>W_y</i>	
	72527	<i>J_x</i>	<i>W_x</i>	FERMAVETRO TUBOLARE DA 35.5 MM (PAG. 4.19)
	0.435	<i>J_y</i>	<i>W_y</i>	

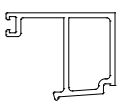
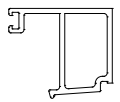
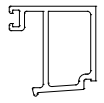
 SAGOMA	ARTICOLO	INERZIA	MODULO	DESCRIZIONE
	PESO (Kg/m)	cm⁴	cm³	
	72528	<i>J_x</i>	<i>W_x</i>	FERMAVETRO TUBOLARE DA 33 MM (PAG. 4.19)
	0.425	<i>J_y</i>	<i>W_y</i>	
	72529	<i>J_x</i>	<i>W_x</i>	FERMAVETRO TUBOLARE DA 30.5 MM (PAG. 4.19)
	0.415	<i>J_y</i>	<i>W_y</i>	
	72530	<i>J_x</i>	<i>W_x</i>	FERMAVETRO TUBOLARE DA 25.5 MM (PAG. 4.19)
	0.395	<i>J_y</i>	<i>W_y</i>	



Profilati Scala 1:1 

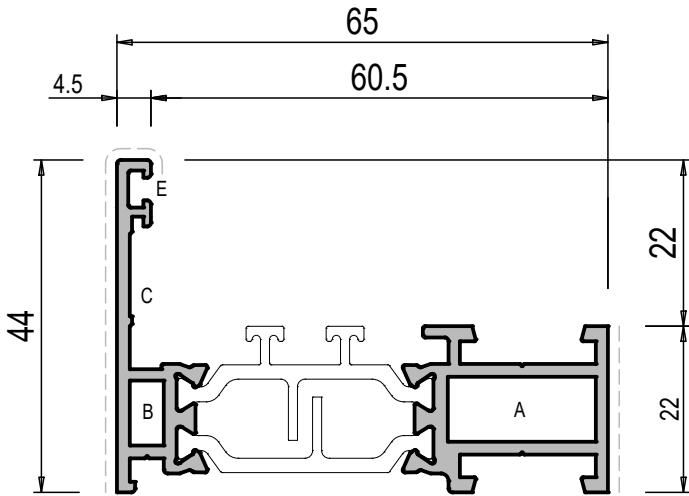

665M00

TELAIO FISSO "L"		Jx	2.8
PESO	g/m	1113	
		Jy	16.1
S. VISTA	mm	70.5	
		Wx	0.7
A	TS204	GA119	TI015
B	TS206		
C	G501N		
E	G112		

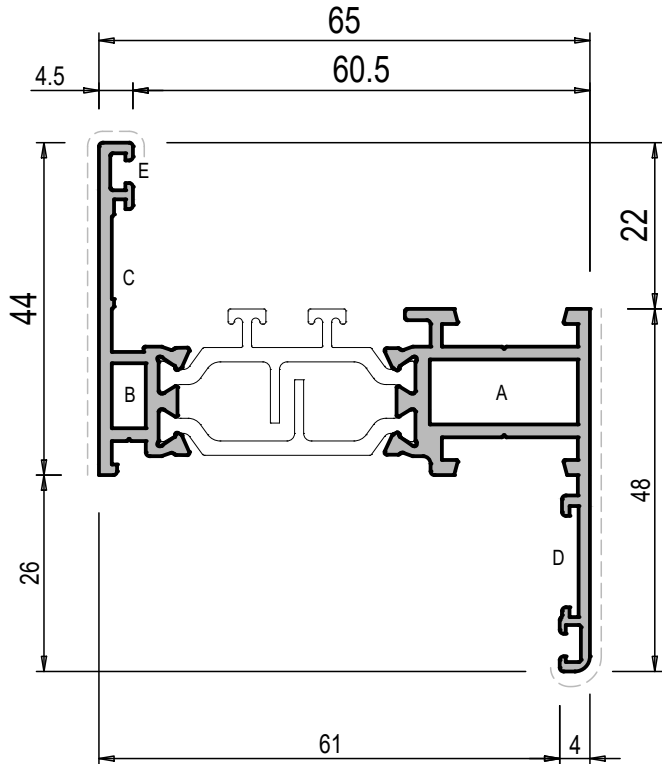

665M05

TELAIO FISSO "Z"		Jx	5.6
PESO	g/m	1247	
		Jy	20.3
S. VISTA	mm	100.5	
		Wx	1.4
D	G269		
E	G112		

ANTE CAMERA EUROPEA

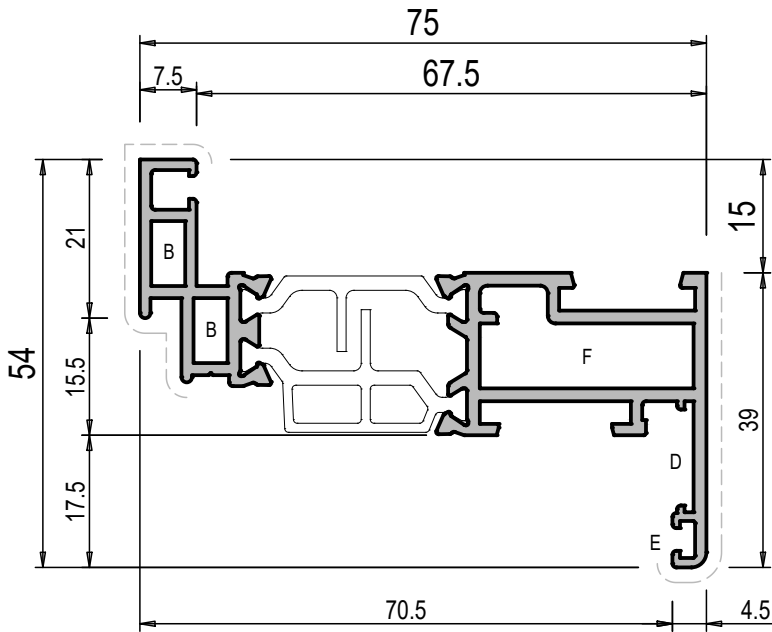

665M01

ANTA "Z" CAMERA EUROPEA		Jx cm ⁴	4.2
PESO g/m	1334	Jy cm ⁴	23.8
S. VISTA mm	90	Wx cm ³	1.4
		Wy cm ³	6.3

F		TS205			GA119	TI015
B		TS206				
D		G269				
E		G112				

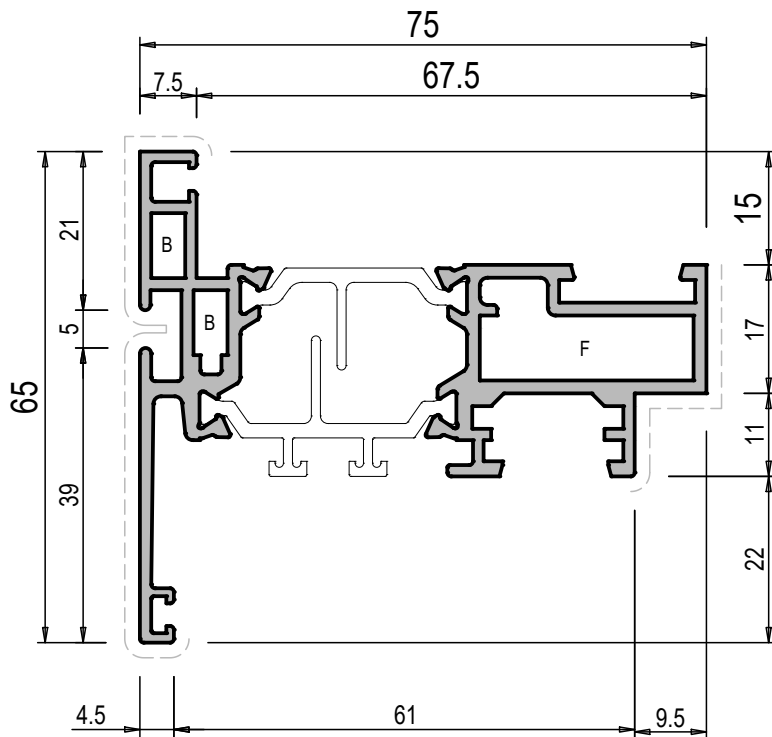

665M02

ANTA "T" CAMERA EUROPEA		Jx cm ⁴	7.0
PESO g/m	1629	Jy cm ⁴	27.3
S. VISTA mm	118	Wx cm ³	2.1
		Wy cm ³	6.3

F		TS205			GA119	TI015
B		TS206				

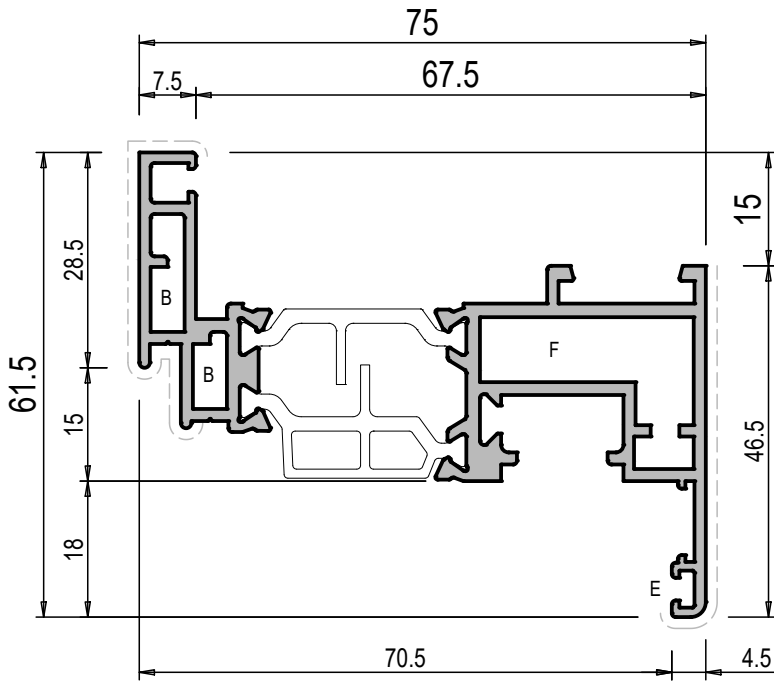

665M03

ANTA "Z" PISTA 16		Jx	cm ⁴	6.2	
PESO	g/m	1562	Jy	cm ⁴	28.0
S. VISTA	mm	105	Wx	cm ³	2.0
			Wy	cm ³	7.3

F	↖	TS205			GA120	TI015
B	↗	TS206				
E	↘	G112				

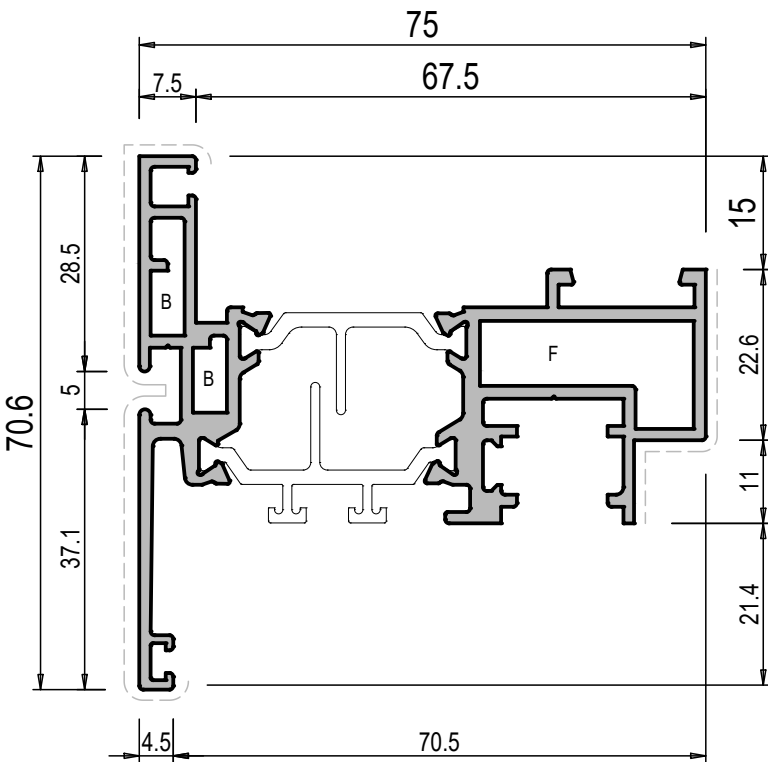

665M04

ANTA "T" PISTA 16		Jx	cm ⁴	9.2	
PESO	g/m	1785	Jy	cm ⁴	30.0
S. VISTA	mm	131	Wx	cm ³	2.4
			Wy	cm ³	6.7

F	↖	TS205			GA120	TI015
B	↗	TS206				

TRAVERSI

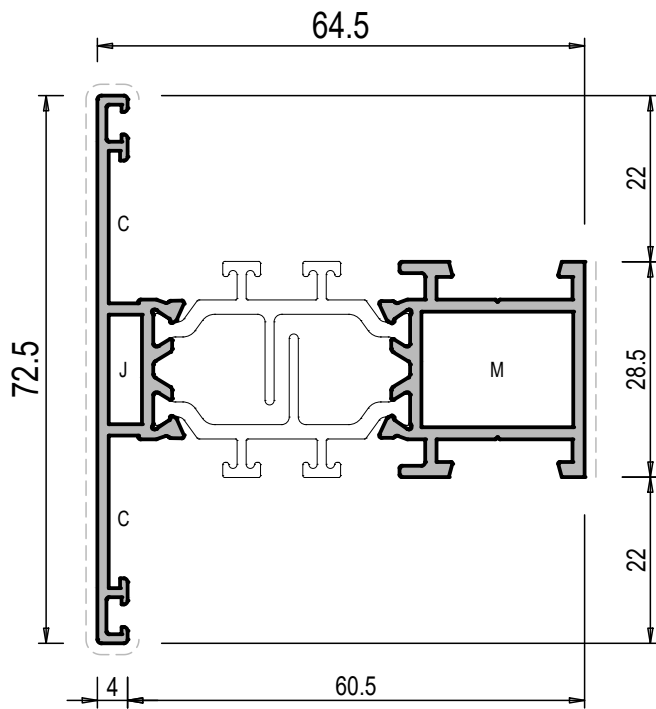

665020

TRAVERSO PER TELAIO		Jx cm ⁴	6.8
PESO g/m	1294	Jy cm ⁴	18.5
S. VISTA mm	109	Wx cm ³	1.9
		Wy cm ³	4.9

C		G501N			
M		G199		GA101	TI002
J		TS073		GA112	

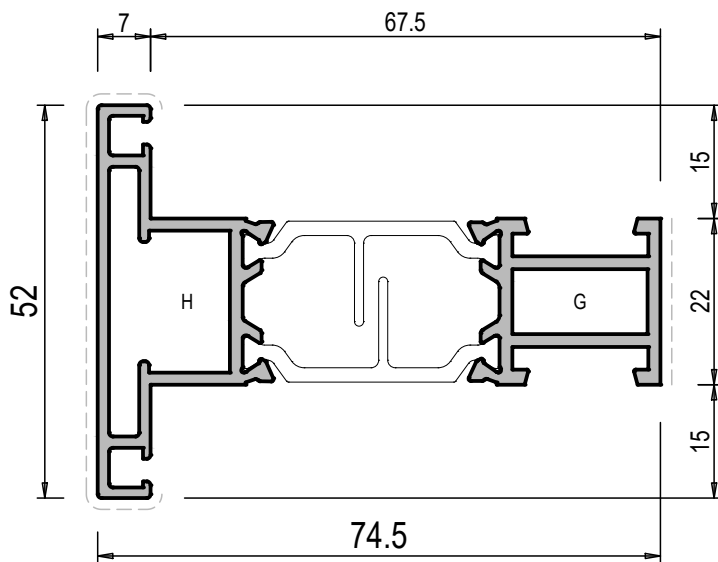

665M07

TRAVERSO PER ANTA		Jx cm ⁴	4.9
PESO g/m	1334	Jy cm ⁴	23.8
S. VISTA mm	88	Wx cm ³	2.1
		Wy cm ³	5.6

G		TS090			
H		TS091			

ZOCCOLO RIPORTATO E SOGLIA RIBASSATA

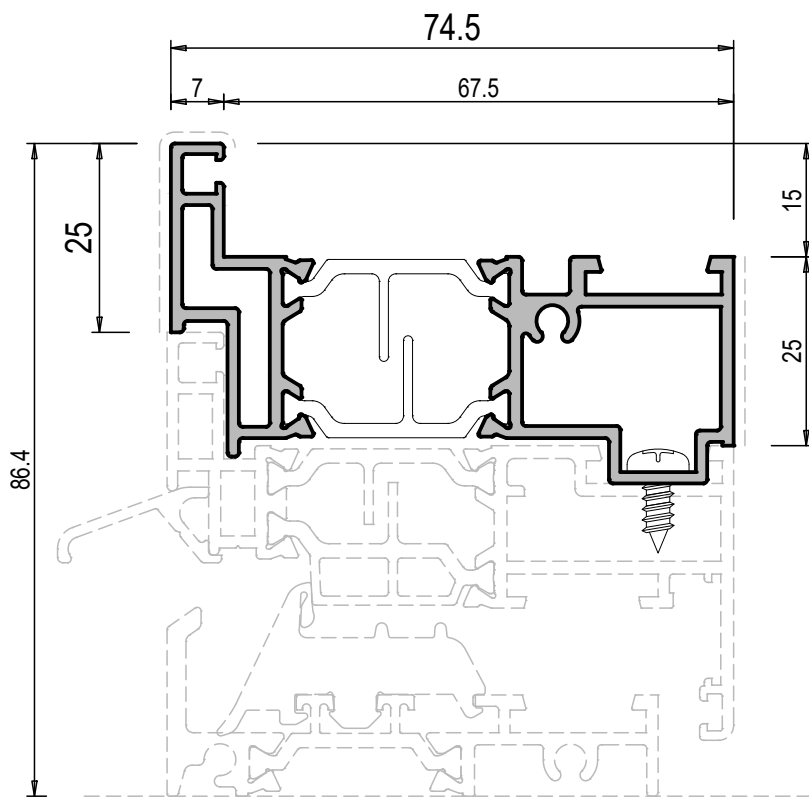

665M08

ZOCCOLO RIP. PER ANTA			
PESO g/m	1363	Jx cm ⁴	4.9
S. VISTA mm	57	Jy cm ⁴	21.7
		Wx cm ³	2.1
		Wy cm ³	5.6

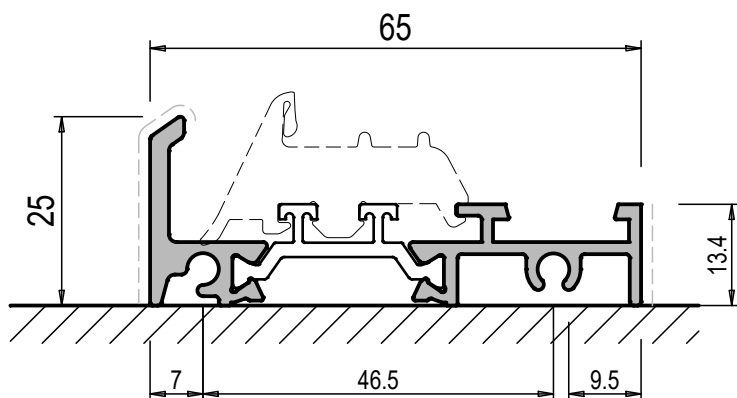

665087

SOGLIA RIBASSATA			
PESO g/m	766	Jx cm ⁴	
S. VISTA mm	40	Jy cm ⁴	
		Wx cm ³	
		Wy cm ³	

RIPORTI CENTRALI

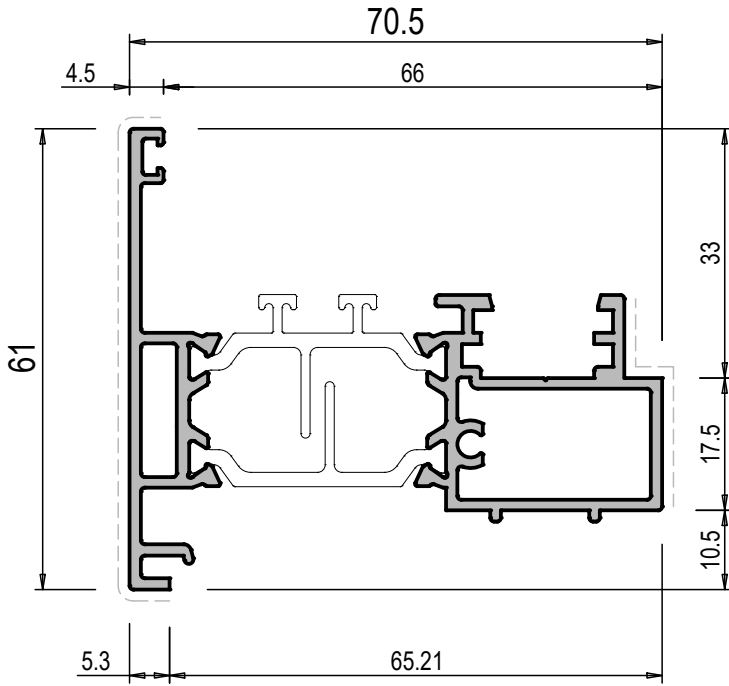

665003

RIPORTO PIANO		Jx	6.0
PESO	1340	Jy	21.2
S. VISTA	102	Wx	1.7
mm		Wy	5.1

J	TT065	CP. TAPPI		

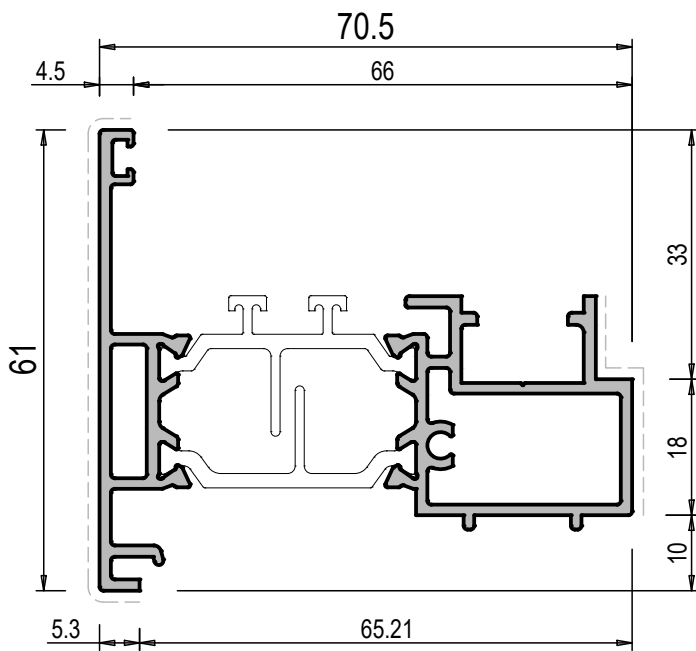

665018

RIPORTO PIANO PISTA 16 INT. 9		Jx	6.1
PESO	1348	Jy	21.3
S. VISTA	104	Wx	1.7
mm		Wy	5.1

K	TT066	CP. TAPPI		

TELAIO PER ANTA A SCOMPARSA

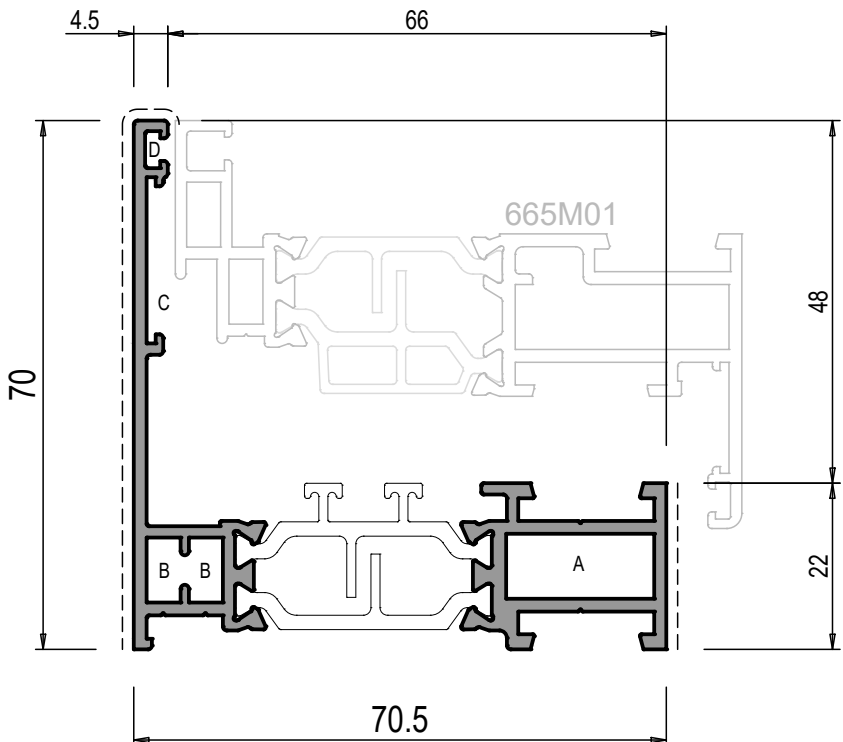

665M09

TELAIO FISSO "L"			Jx	10.5
PESO	1297		Jy	21.7
S. VISTA	100		Wx	2.1
			Wy	5.6
A	TS204		GA119	TI015
B	TS206			
C	G267			
E	G112			

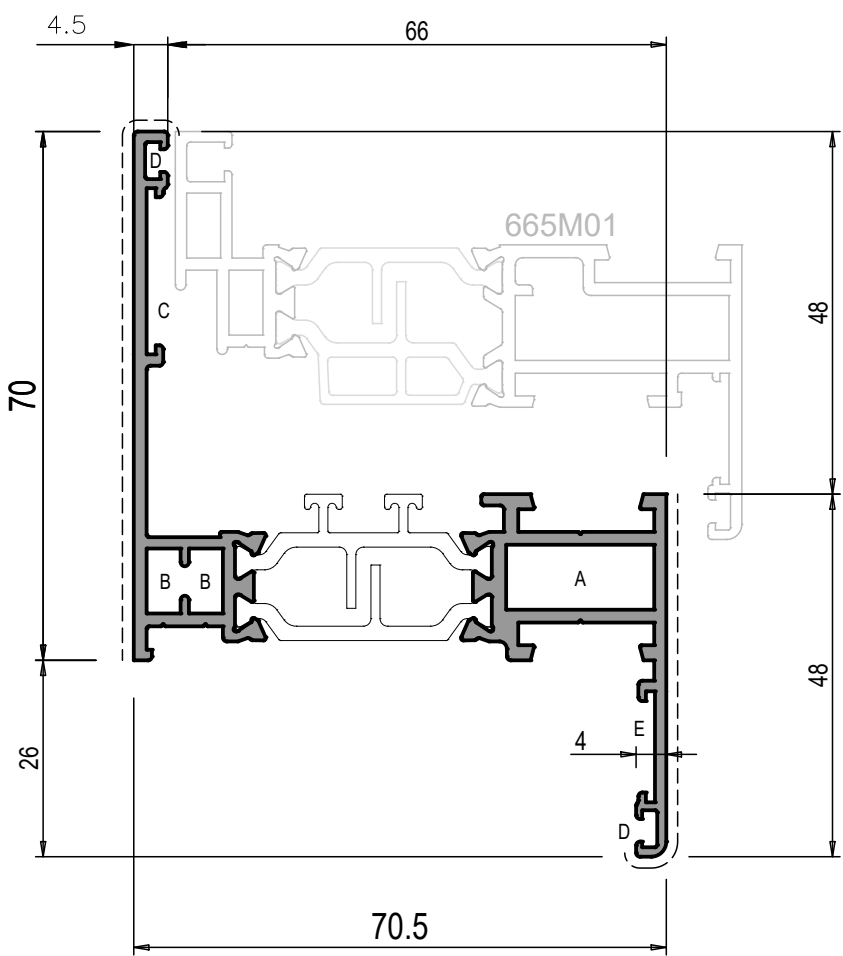

665M11

TELAIO FISSO "Z"			Jx	13.3
PESO	1434		Jy	27.3
S. VISTA	132		Wx	2.1
			Wy	7
A	TS204		GA119	TI015
B	TS206			
C	G267			
D	G112			
E	G269			

Profilati Scala 1:1



RIPORTO CENTRALE ANTA A SCOMPARSA

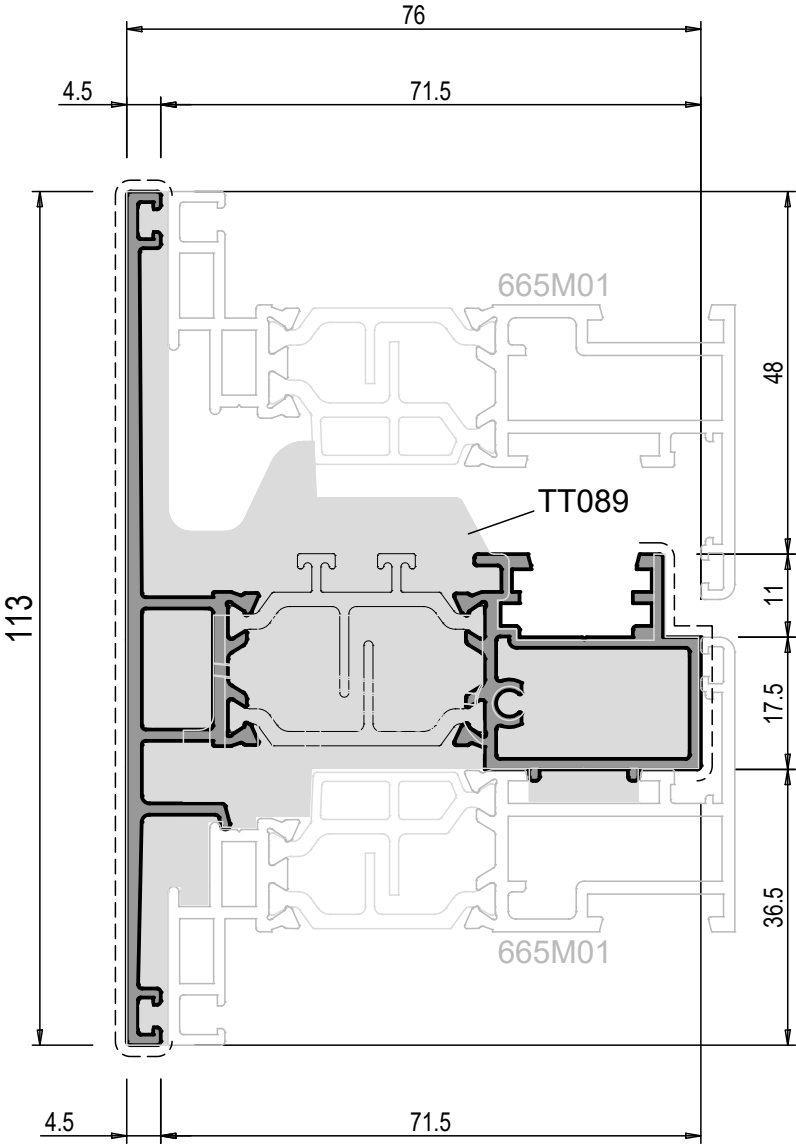

665M10

RIPORTO CENTRALE			
PESO g/m	1733	Jx cm ⁴	23.1
S. VISTA mm	158	Jy cm ⁴	32.2
		Wx cm ³	3.5
		Wy cm ³	7

ANTA LINEA FERRO

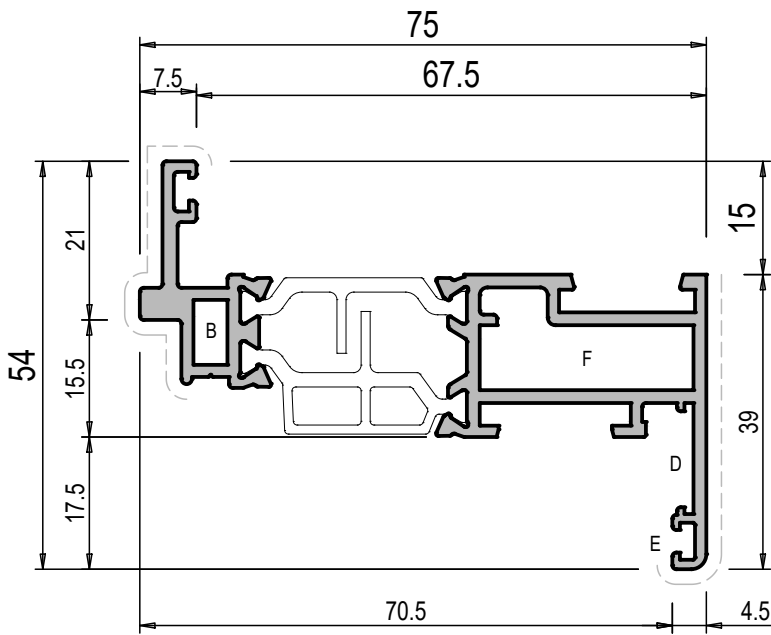

665107

ANTA "Z" CAMERA EUROPEA LINEA FERRO		Jx cm ⁴	3.5
PESO g/m	1302	Jy cm ⁴	23.1
S. VISTA mm	90	Wx cm ³	1.4
		Wy cm ³	6.3
F	TS205	GA119	TI015
B	TS206		
D	G269		
E	G112		

FERMAVETRI LINEA FERRO

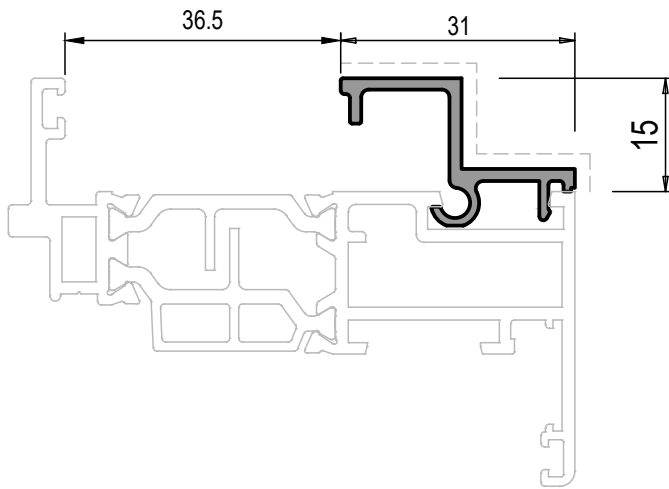

665415	
PESO g/m	264
S. VISTA mm	46

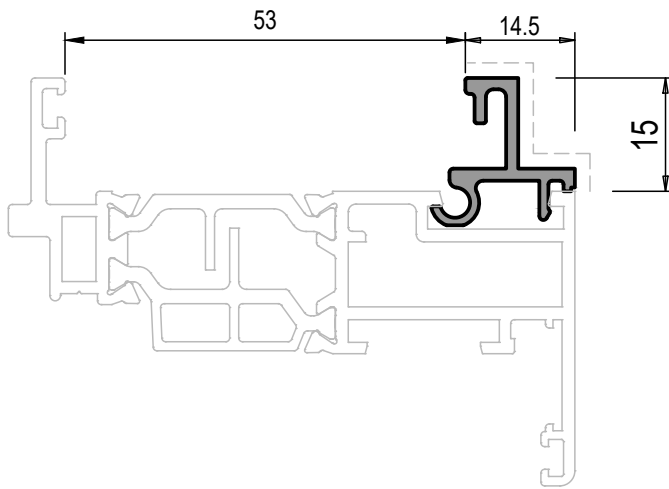

665414	
PESO g/m	226
S. VISTA mm	29.5

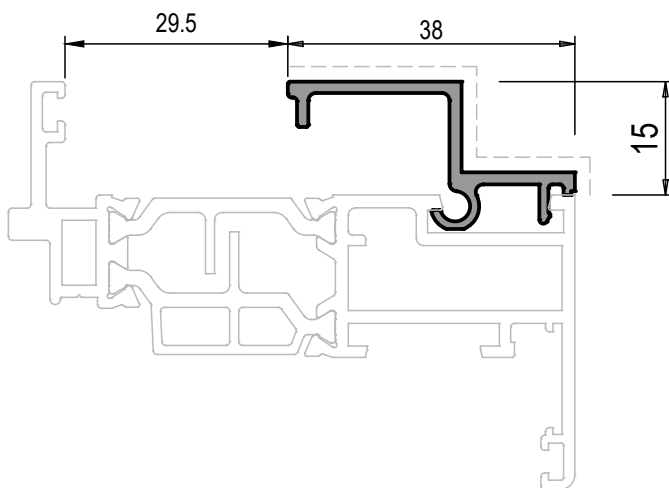

665420	
PESO g/m	293
S. VISTA mm	53

40269

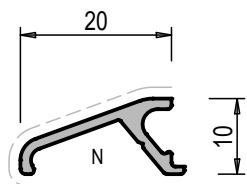

GOCCIOLATOIO UNIVERSALE		N	GT118
PESO g/m	141		CP. TAPPI
S. VISTA mm	23		

665276

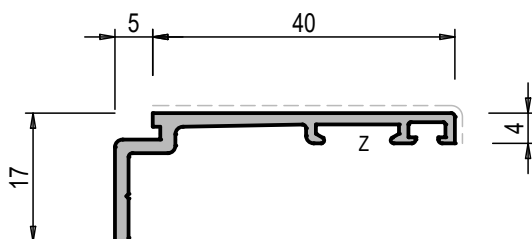

COPRIFILO "A"		Z	✓	G255
PESO g/m	306			
S. VISTA mm	44			

665277

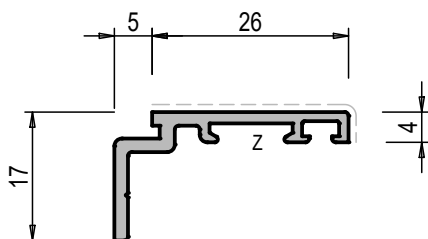

COPRIFILO "B"		Z	✓	G255
PESO g/m	244			
S. VISTA mm	30			

665278

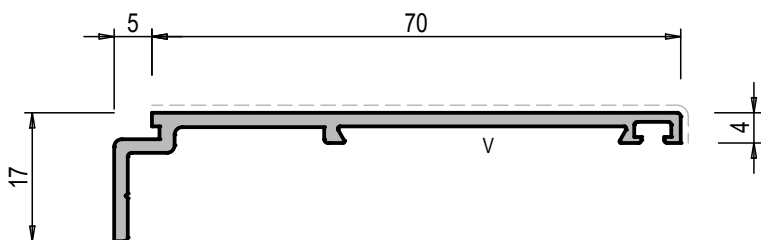

COPRIFILO "C"		V	✓	G220
PESO g/m	475			
S. VISTA mm	74			

FERMAVETRI PER ANTE

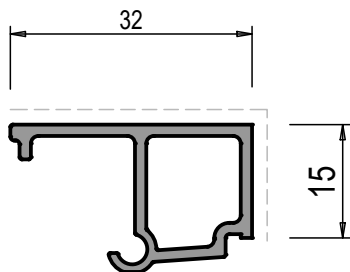

665332	
PESO g/m	343
S. VISTA mm	51

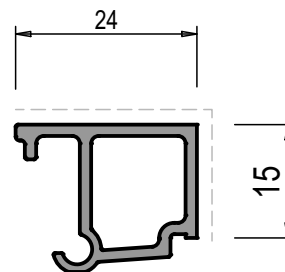

665359	
PESO g/m	310
S. VISTA mm	42

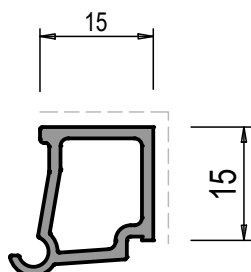

665360	
PESO g/m	259
S. VISTA mm	33

FERMAVETRI PER TELAIO

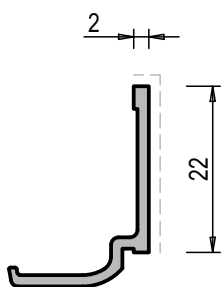

40086	
PESO g/m	178
S. VISTA mm	24

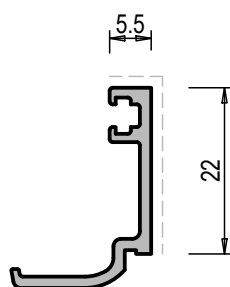

40085	
PESO g/m	210
S. VISTA mm	27

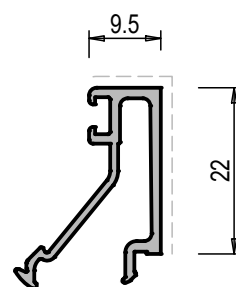

40249	
PESO g/m	242
S. VISTA mm	34

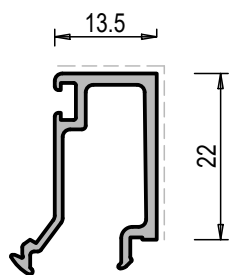

40030	
PESO g/m	263
S. VISTA mm	35

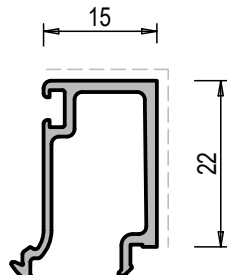

40217	
PESO g/m	267
S. VISTA mm	40

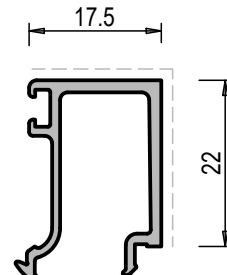

40185	
PESO g/m	280
S. VISTA mm	39

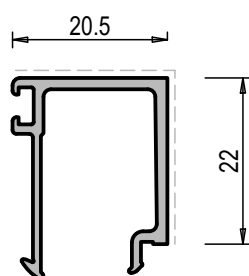

40029	
PESO g/m	283
S. VISTA mm	42

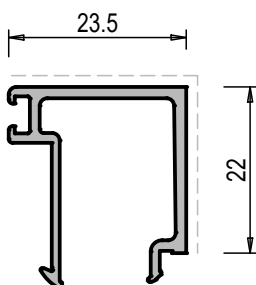

40087	
PESO g/m	303
S. VISTA mm	45

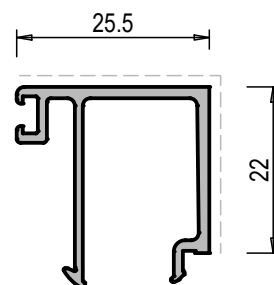

40007	
PESO g/m	318
S. VISTA mm	47

FERMAVETRI PER TELAIO

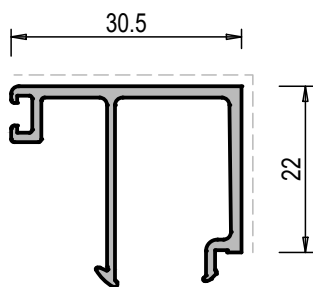

40039	
PESO g/m	339
S. VISTA mm	52

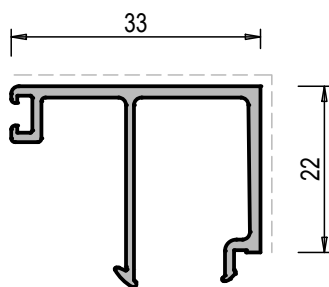

40111	
PESO g/m	347
S. VISTA mm	55

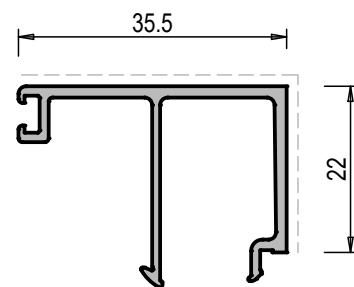

40037	
PESO g/m	359
S. VISTA mm	57

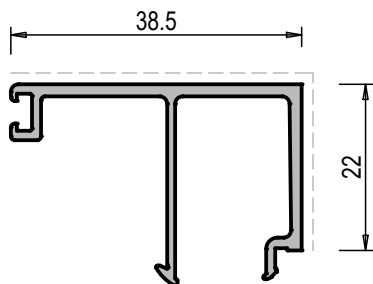

40275	
PESO g/m	379
S. VISTA mm	60

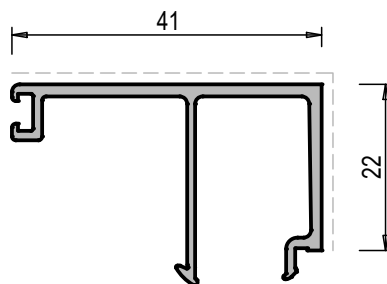

72505	
PESO g/m	392
S. VISTA mm	63

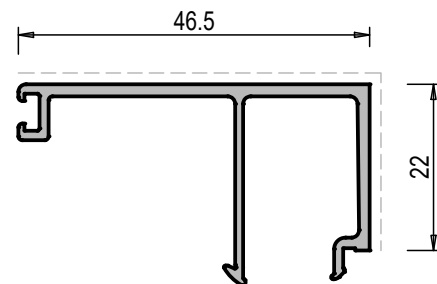

40277	
PESO g/m	414
S. VISTA mm	69

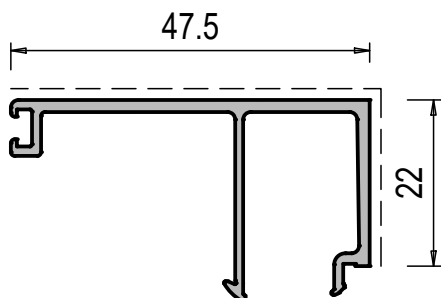

72506	
PESO g/m	420
S. VISTA mm	70

FERMAVETRI PER TELAIO

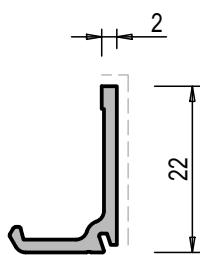

40098	
PESO g/m	169
S. VISTA mm	24

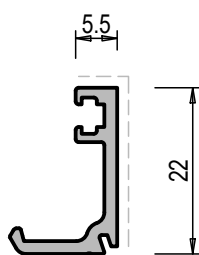

40097	
PESO g/m	199
S. VISTA mm	27

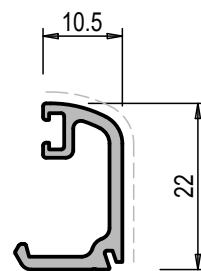

40096	
PESO g/m	221
S. VISTA mm	30

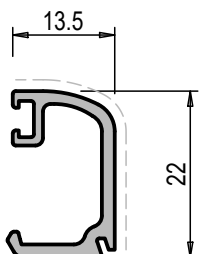

40095	
PESO g/m	236
S. VISTA mm	33

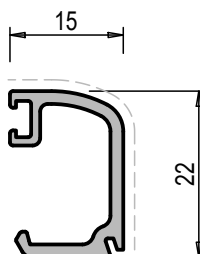

40218	
PESO g/m	243
S. VISTA mm	36

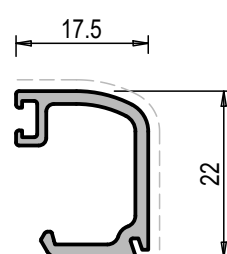

40187	
PESO g/m	254
S. VISTA mm	37

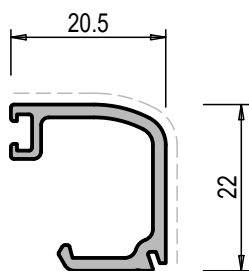

40094	
PESO g/m	268
S. VISTA mm	40

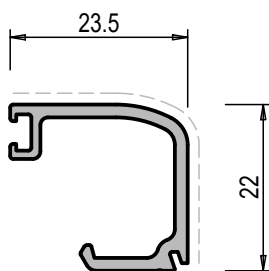

40093	
PESO g/m	282
S. VISTA mm	43

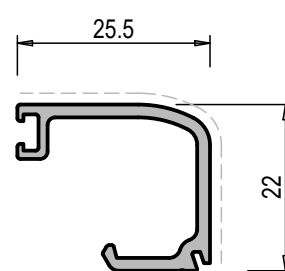

40092	
PESO g/m	291
S. VISTA mm	45

FERMAVETRI PER TELAIO

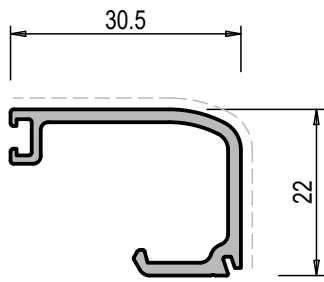

40091	
PESO g/m	324
S. VISTA mm	50

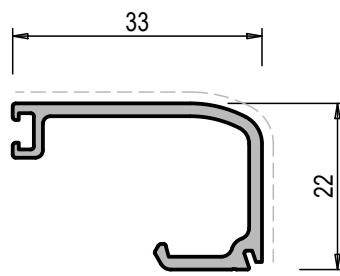

40090	
PESO g/m	336
S. VISTA mm	53

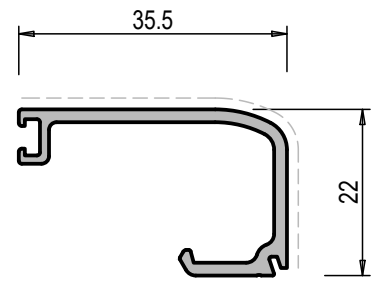

40089	
PESO g/m	348
S. VISTA mm	55

FERMAVETRI PER TELAIO

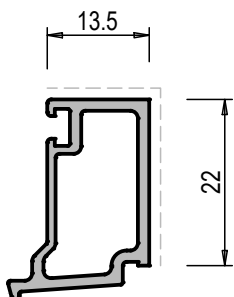

40327	
PESO g/m	311
S. VISTA mm	35.5

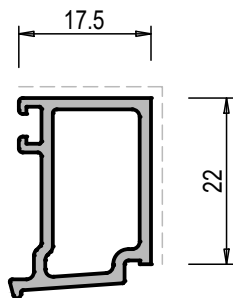

41258	
PESO g/m	342
S. VISTA mm	39.5

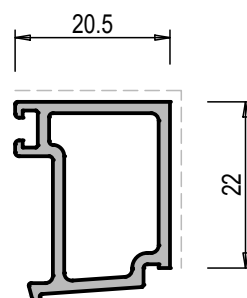

41259	
PESO g/m	359
S. VISTA mm	42.5

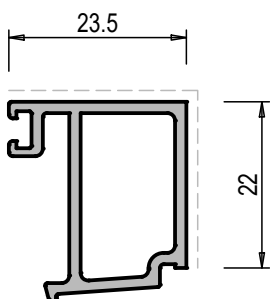

40328	
PESO g/m	425
S. VISTA mm	45.5

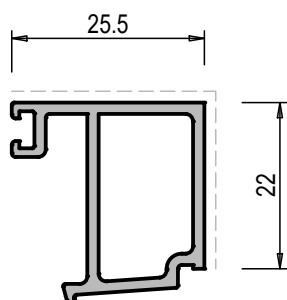

72530	
PESO g/m	395
S. VISTA mm	47.5

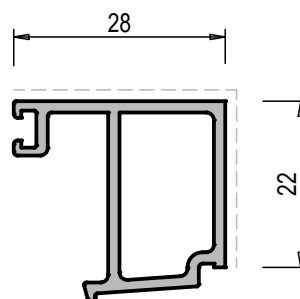

40329	
PESO g/m	405
S. VISTA mm	50

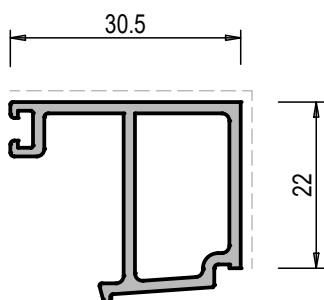

72529	
PESO g/m	415
S. VISTA mm	52.5

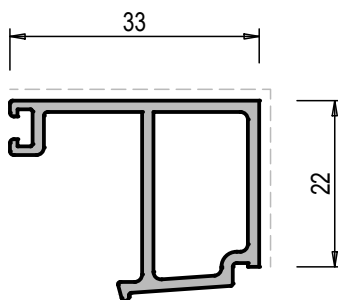

72528	
PESO g/m	425
S. VISTA mm	55

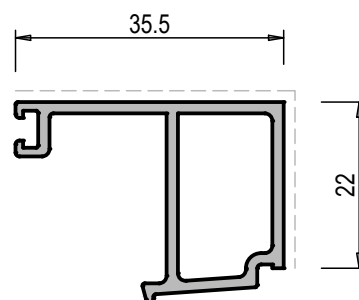

72527	
PESO g/m	435
S. VISTA mm	57.5

FERMAVETRI PER TELAIO

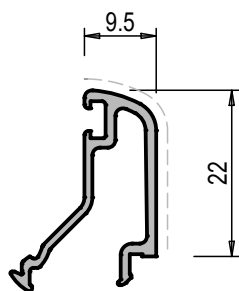

40247	
PESO g/m	229
S. VISTA mm	30

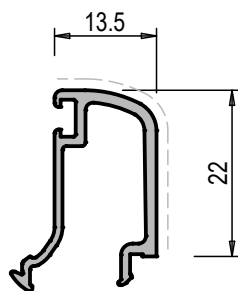

40083	
PESO g/m	252
S. VISTA mm	34

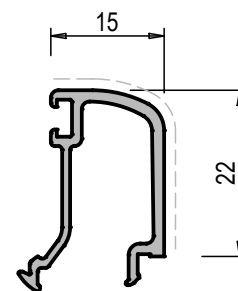

40216	
PESO g/m	259
S. VISTA mm	52.5

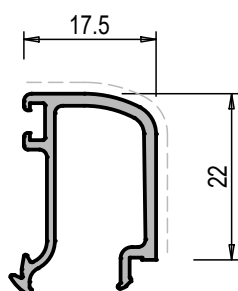

40186	
PESO g/m	272
S. VISTA mm	40

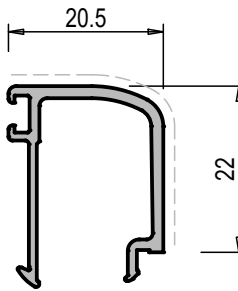

40082	
PESO g/m	274
S. VISTA mm	44

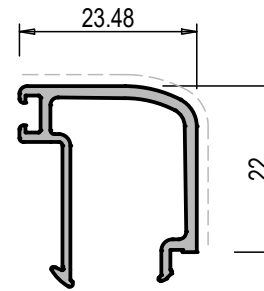

40081	
PESO g/m	293
S. VISTA mm	47

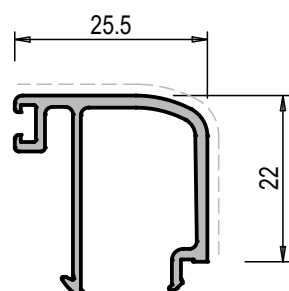

40080	
PESO g/m	312
S. VISTA mm	49

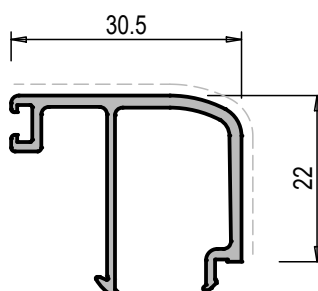

40079	
PESO g/m	332
S. VISTA mm	53

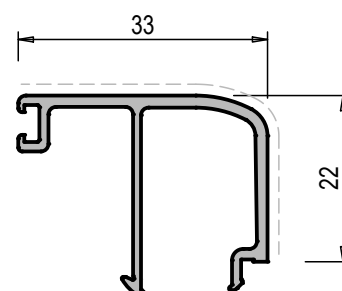

40078	
PESO g/m	342
S. VISTA mm	55

FERMAVETRI PER TELAIO

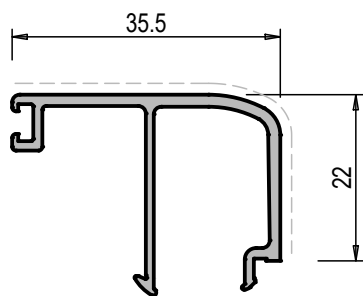

40077	
PESO g/m	352
S. VISTA mm	58

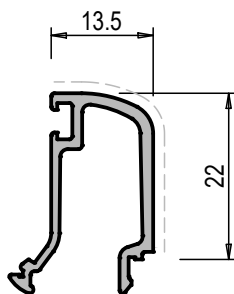

40225	
PESO g/m	261
S. VISTA mm	35

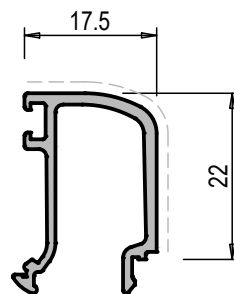

40228	
PESO g/m	278
S. VISTA mm	41

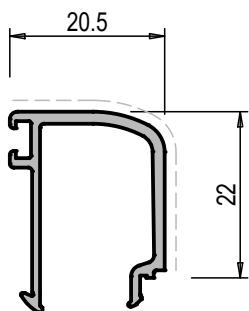

40226	
PESO g/m	270
S. VISTA mm	36

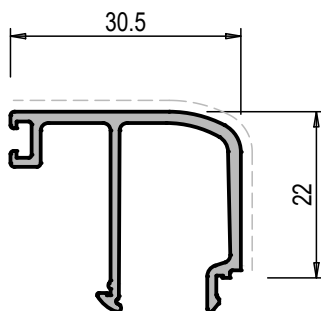

40227	
PESO g/m	341
S. VISTA mm	57

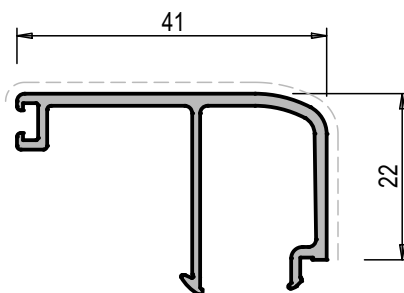

72507	
PESO g/m	380
S. VISTA mm	60

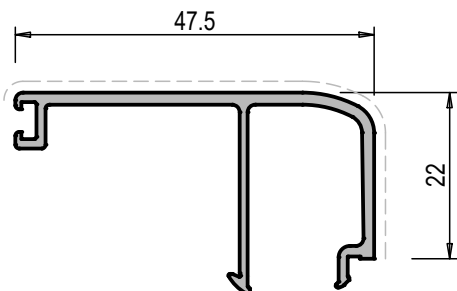

72508	
PESO g/m	416
S. VISTA mm	67

FERMAVETRI PER TELAIO

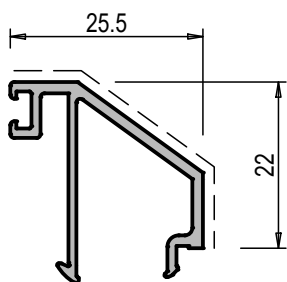

40316	
PESO g/m	283
S. VISTA mm	39

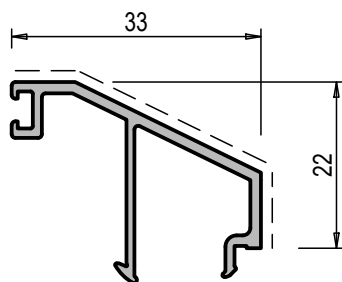

40274	
PESO g/m	298
S. VISTA mm	46

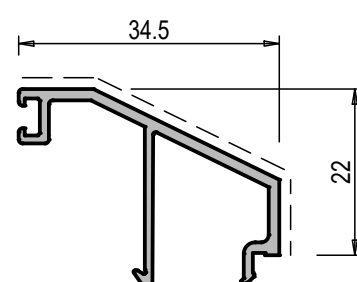

40262	
PESO g/m	302
S. VISTA mm	47

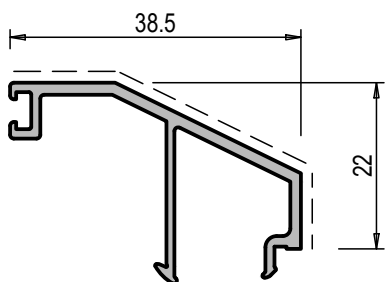

40276	
PESO g/m	330
S. VISTA mm	51

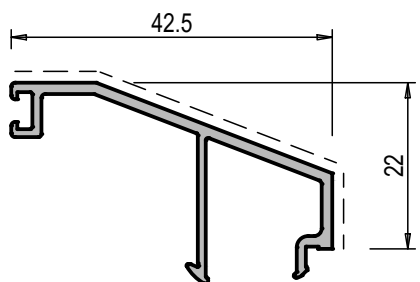

40261	
PESO g/m	327
S. VISTA mm	54

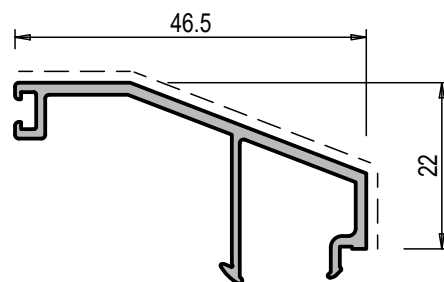

40278	
PESO g/m	357
S. VISTA mm	59

FERMAVETRI PER TELAIO

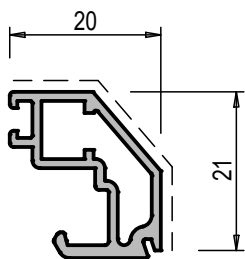

72519	
PESO g/m	303
S. VISTA mm	35

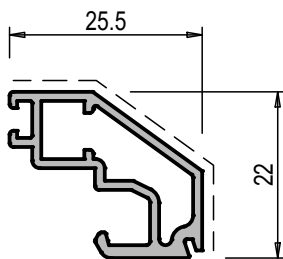

72501	
PESO g/m	331
S. VISTA mm	39

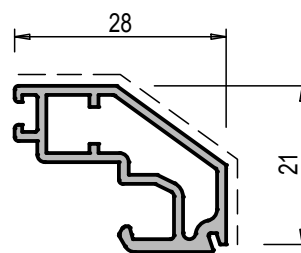

72512	
PESO g/m	348
S. VISTA mm	42

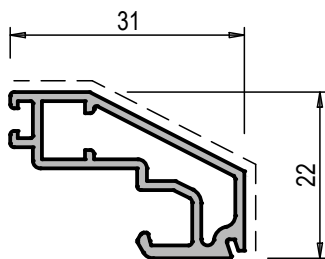

72502	
PESO g/m	364
S. VISTA mm	45

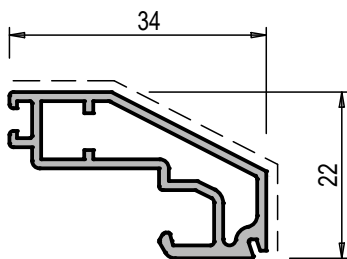

72509	
PESO g/m	382
S. VISTA mm	48

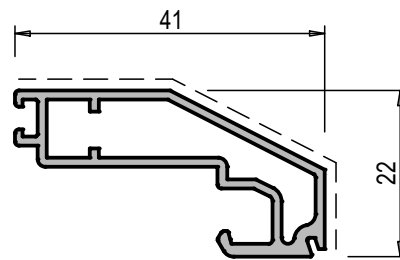

72503	
PESO g/m	428
S. VISTA mm	55

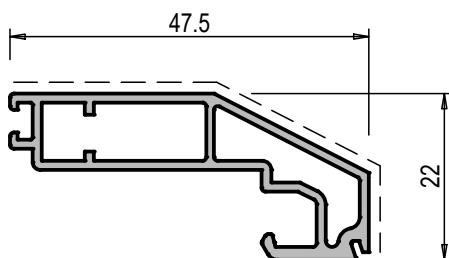

72504	
PESO g/m	492
S. VISTA mm	61

CONFIGURAZIONE FERMAVETRI

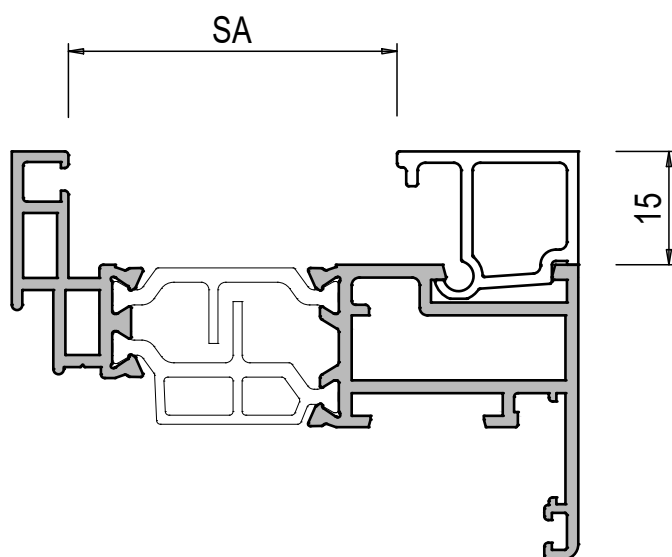
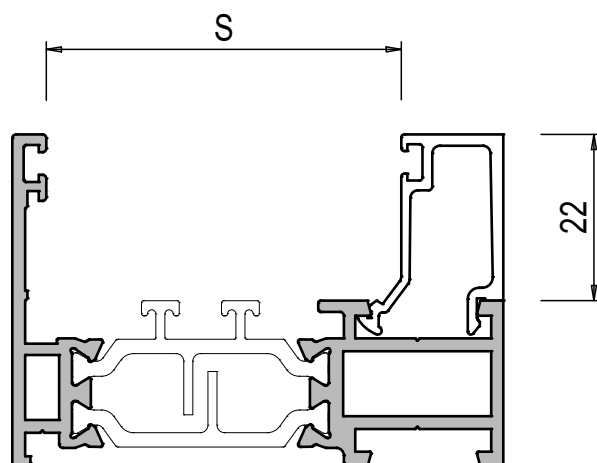







CINGIVETRO ESTERNA	
	<p>TG032</p> <p>DA mm 3</p>

CINGIVETRO INTERNA	
	<p>TG304</p> <p>DA mm 3</p> <p>A mm 4</p>
	<p>TG305</p> <p>DA mm 5</p> <p>A mm 6</p>
	<p>TG306</p> <p>DA mm 5</p> <p>A mm 6</p>

LE MISURE **S** ED **SA** INDICANO LO SPAZIO UTILE PER L'ALLOGGIAMENTO DEL VETROCAMERA.
 SOTTRARRE L'INGOMBRO DELLE GUARNIZIONE CINGIVETRO INTERNA ED ESTERNA CHE VENGONO UTILIZZATE

APPLICAZIONE FERMAVETRI

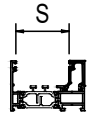
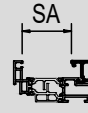

MISURE FERMAVETRO	PIANI 	ARROTONDATI 	CLIP 	CONTRASTO 	DESIGN 	CONTRASTO H = 15mm 		
2 mm	40086		40098				S = 58.5	SA = -
5.5 mm	40085		40097				S = 55	SA = -
9.5 mm	40249	40247					S = 51	SA = -
10.5 mm	40031		40096				S = 50	SA = -
13.5 mm	40030	40083	40095	40327			S = 47	SA = -
15 mm	40217	40216	40218			665360	S = 45.5	SA = 52.5
17.5 mm	40185	40186	40187	41258			S = 43	SA = -
20.5 mm	40029	40082	40094	41259			S = 40	SA = -
23.5 mm	40087	40081	40093	40328			S = 37	SA = -
24 mm						665359	S = 37	SA = 43.5
25.5 mm	40007	40080	40092	72530	40316		S = 35	SA = -
28 mm				40329			S = 32.5	SA = -
30.5 mm	40039	40079	40091	72529			S = 30	SA = -
32 mm						665332	S = 29.5	SA = 35.5
33 mm	40111	40078	40090	72528	40274		S = 27.5	SA = -
34.5 mm					40262		S = 26	SA = -
35.5 mm	40037	40077	40089	72527			S = 25	SA = -
38.5 mm	40275				40276		S = 22	SA = -
41 mm	72505	72507					S = 19.5	SA = -
42.5 mm					40261		S = 18	SA = -
46.5 mm	40277				40278		S = 14	SA = -
47.5 mm	72506	72508					S = 13	SA = -
52.5 mm	40279				40280		S = 8	SA = -



Soluzioni Disponibili 

SEZIONE CAMERA EUROPEA CERNIERA STANDARD CERNIERA A SCOMPARSA

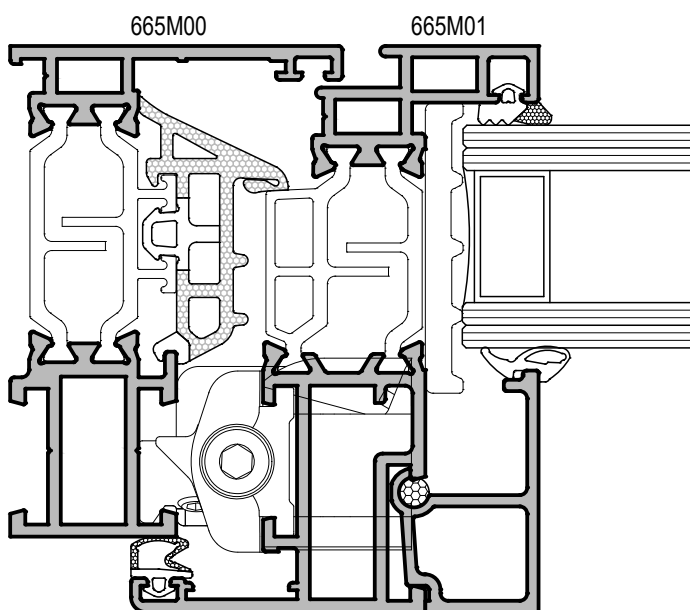
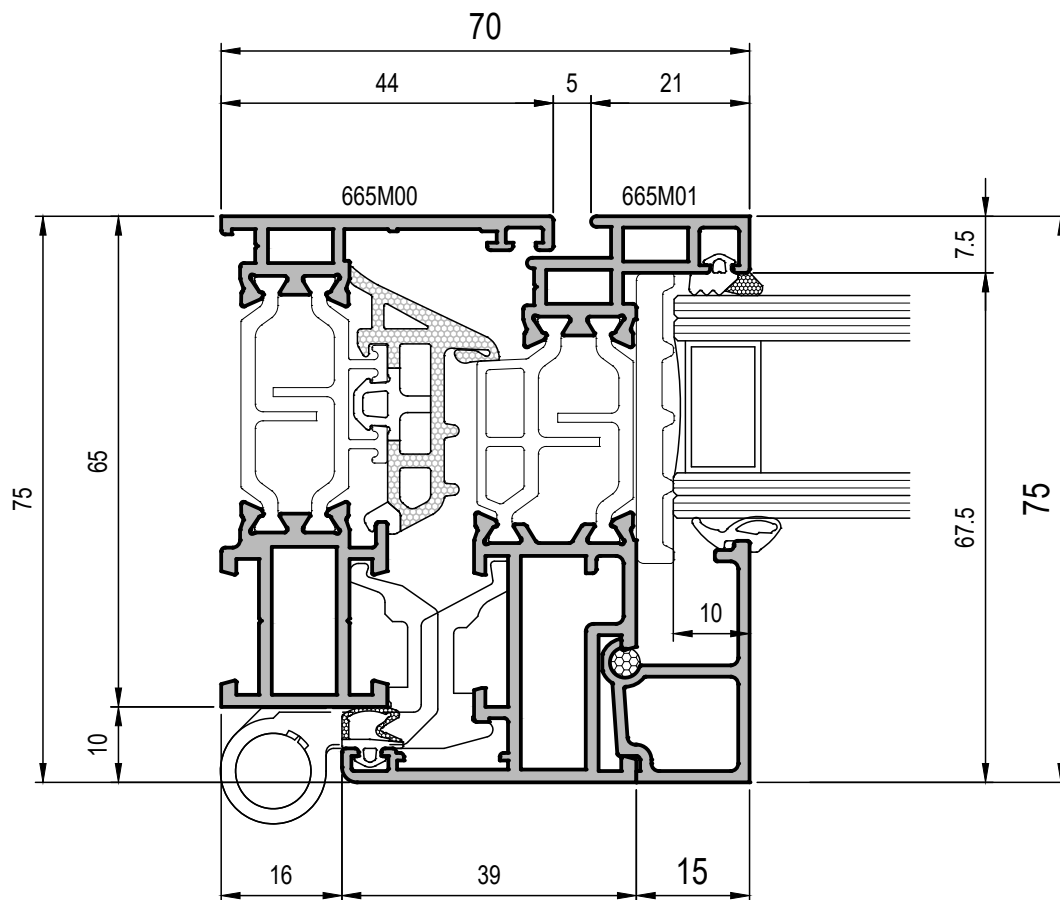

SEZIONE PISTA 16 INT. 9 CERNIERA STANDARD CERNIERA A SCOMPARSA

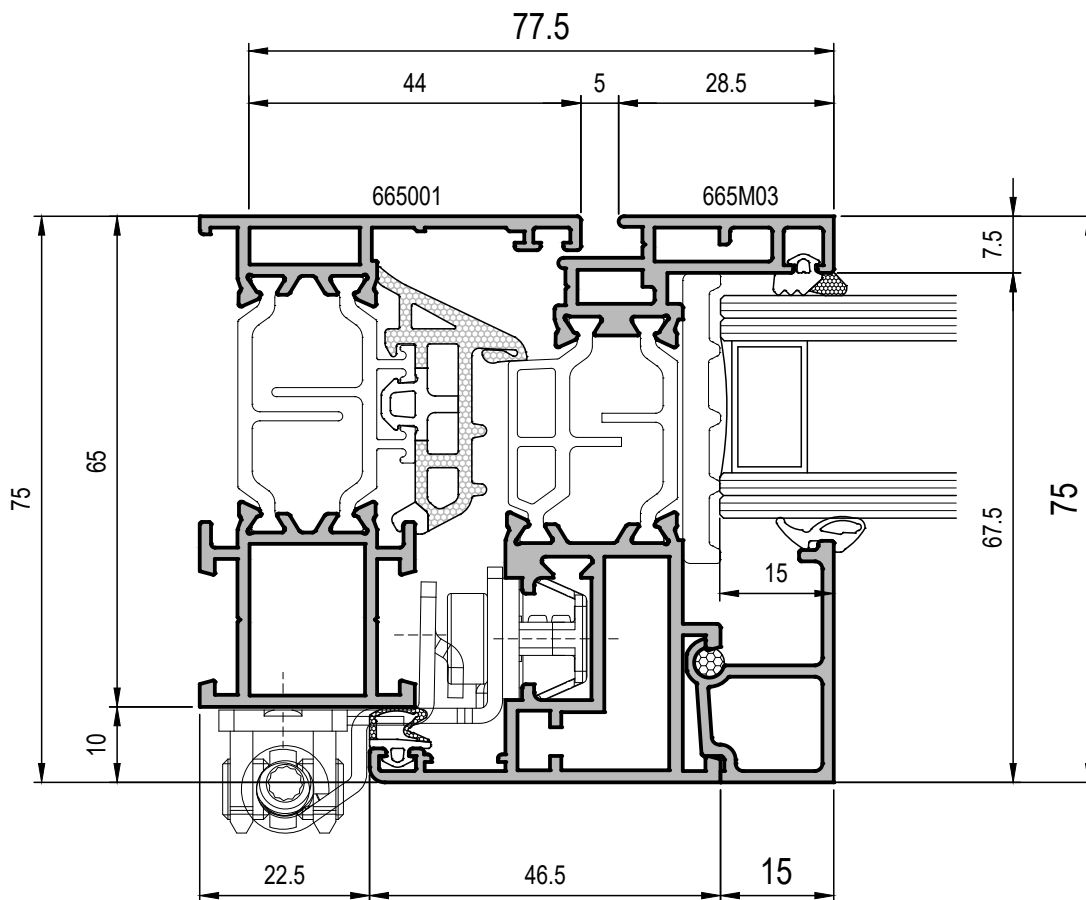

N.B. NEL CASO DI UTILIZZO DI CERNIERE A 2 O 3 ALI STANDARD PER LA SOLUZIONE PISTA 16 INT.9 mm SARÀ NECESSARIO UTILIZZARE I PROFILATI TELAIO DEL SISTEMA DOGMA (VEDERE CATALOGO DEDICATO)

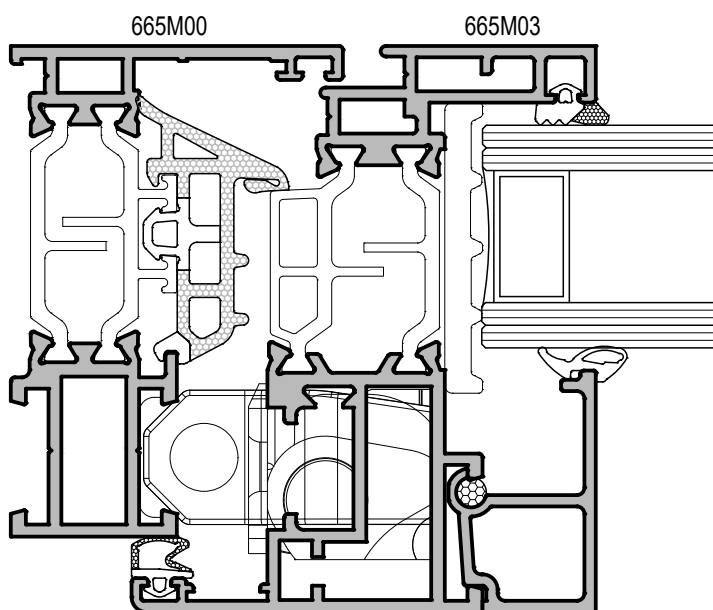

SEZIONE ANTA A SCOMPARSA

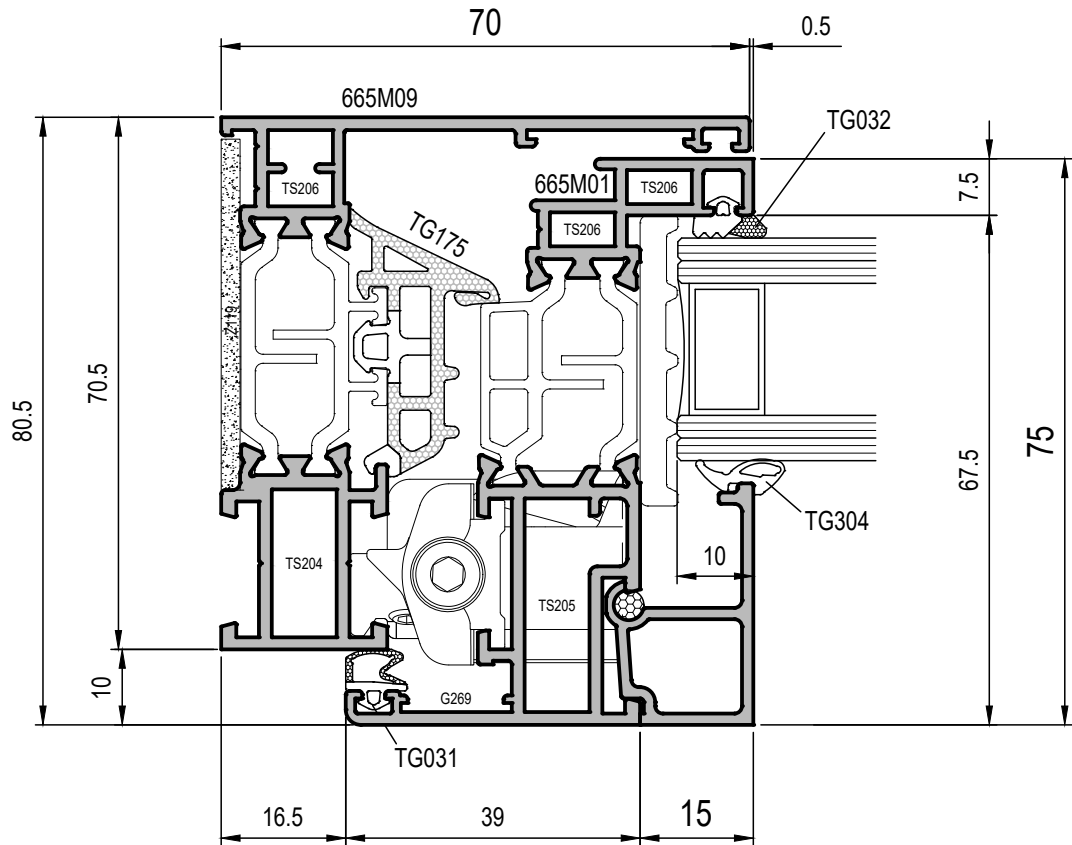

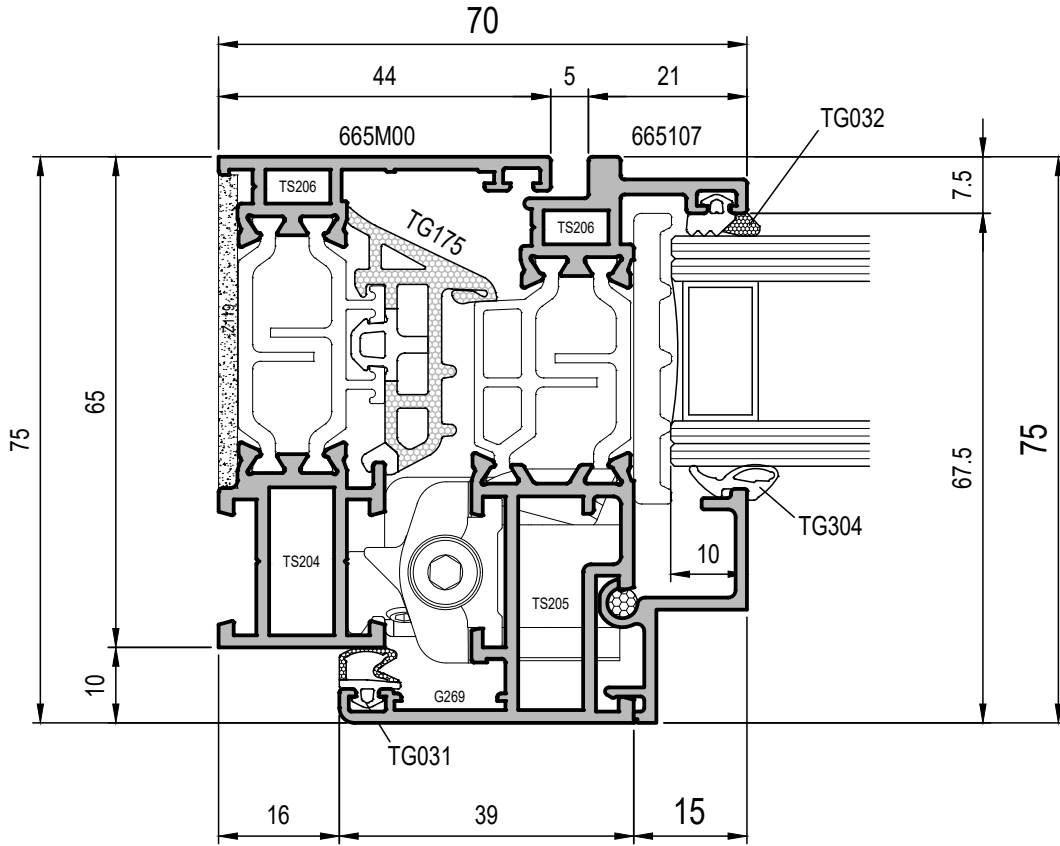



Schede di Taglio 

FINESTRA AD UN' ANTA GIUNTO APERTO APERTURA INTERNA CAMERA EUROPEA

DISTINTA PROFILATI

CODICE	PROFILATO	DESCRIZIONE	MISURA TAGLIO	TAGLIO	N°
665M00		TELAIO L	L		2
			H		2
665M01		ANTA Z CAMERA EUROPEA	L - 32		2
			H - 32		2
665332		FERMAVETRO	L - 110		2
			H - 140		2
6405		ASTINA DI COMANDO	DIPENDE DA ACCESSORIO DI COMANDO		DIPENDE DA ACCESSORIO DI COMANDO

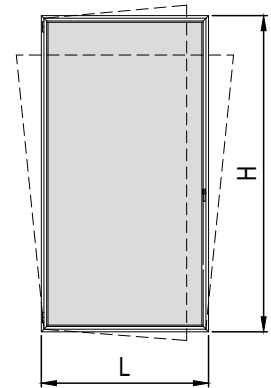

VISTA INTERNA

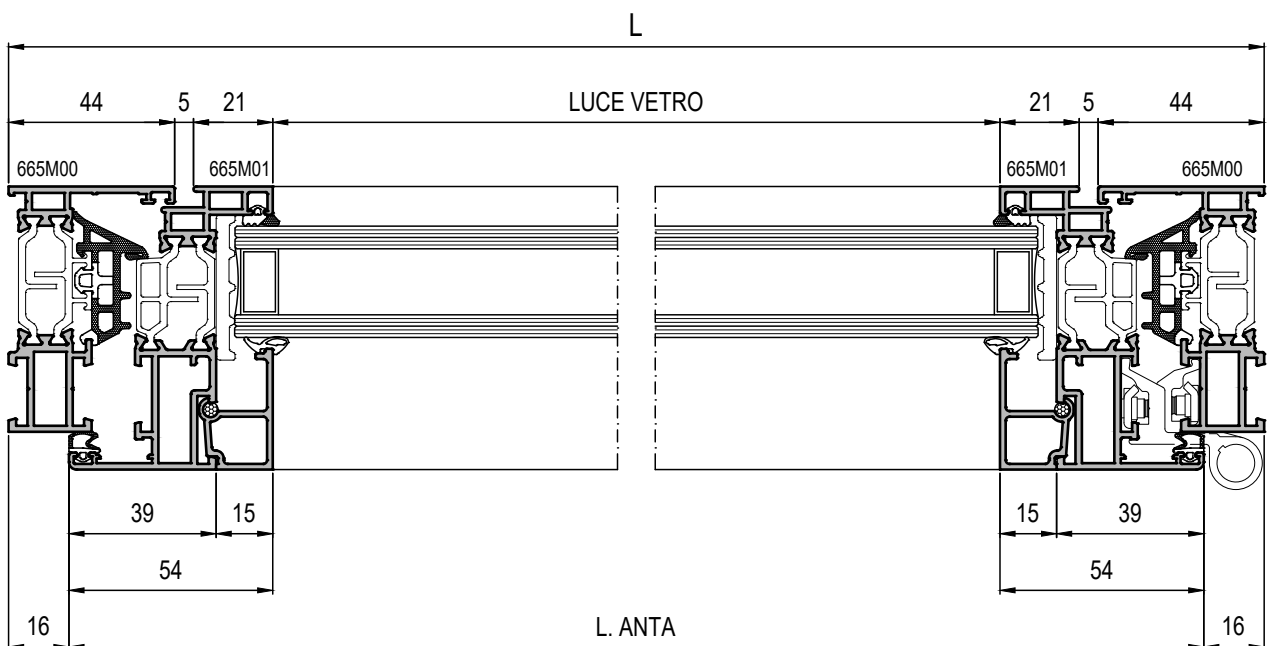

DISTINTA ACCESSORI

CODICE	DESCRIZIONE	N°
TA089	REGOLO TELAIO CAMERA SEMPLICE	TABELLA
TS204	SQUADRETTA INTERNA TELAIO	4
TS205	SQUADRETTA INTERNA ANTA	4
TS206	SQUADRETTA ESTERNA TELAIO / ANTA	12
S810	SPINA D8 PER SQUADRETTE INTERNE TELAIO / ANTA	16
S3001	SPINA D3 ACCIAIO PER SQUADRETTE ESTERNE TELAIO / ANTA	24
G266 *	SPINA D3 ALLUM. PER SQUADRETTE ESTERNE TELAIO / ANTA	
G501N	SQUADRETTA A CAMME PER TELAIO	4
G112	SQUADRETTA INOX DI ALLINEAMENTO ANGOLI	8
G269	SQUADRETTA ALLINEAMENTO ANTE	4
G101	CAPPETTA DRENAGGIO ACQUA	2 ... 3
* IN ALTERNATIVA		

N.B. : PER GLI ACCESSORI DI CHIUSURA, MOVIMENTAZIONE E LIMITI PRESTAZIONALI CONSULTARE IL MANUALE DEL FORNITORE DEGLI ACCESSORI.





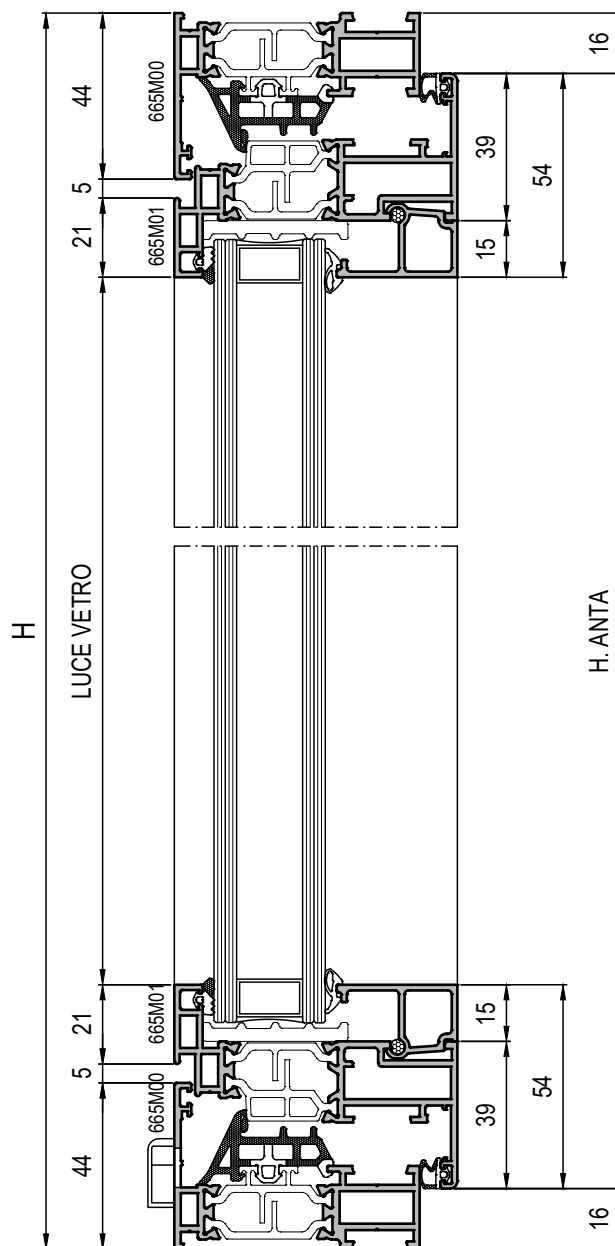







DISTINTA GUARNIZIONI

CODICE	DESCRIZIONE	N°
TG176	ANGOLO VULCANIZZATO	4 Pz.
TG175	GUARNIZIONE DI TENUTA CENTRALE	2L+2H
TG031	GUARNIZIONE DI BATTUTA	2L+2H
	GUARNIZIONE CINGIVETRO ESTERNA	2L+2H
	GUARNIZIONE CINGIVETRO INTERNA	2L+2H
TG307	SOTTOVETRO ISOLANTE	2L+2H
Z119	GUARNIZIONE ISOLANTE	L+2H
* IN ALTERNATIVA		



FINESTRA A DUE ANTE GIUNTO APERTO APERTURA INTERNA CAMERA EUROPEA

DISTINTA PROFILATI

CODICE	PROFILATO	DESCRIZIONE	MISURA TAGLIO	TAGLIO	N°
665M00		TELAIO Z	L		2
			H		2
665M01		ANTA Z CAMERA EUROPEA	$(L/2) - 7.5$		4
			H - 32		3
665M02		ANTA T CAMERA EUROPEA	H - 10		1
665332		FERMAVETRO	$(L/2) - 85.5$		4
			H - 140		4
6405		ASTINA DI COMANDO	DIPENDE DA ACCESSORIO DI COMANDO		DIPENDE DA ACCESSORIO DI COMANDO

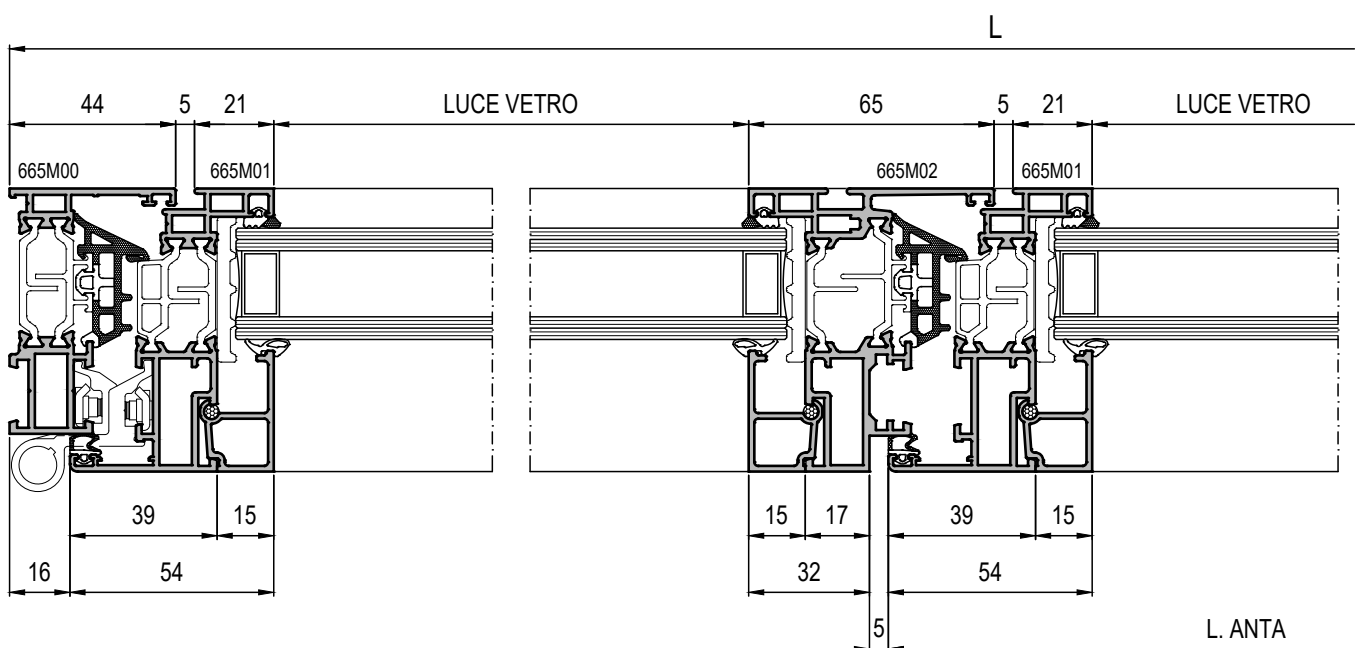
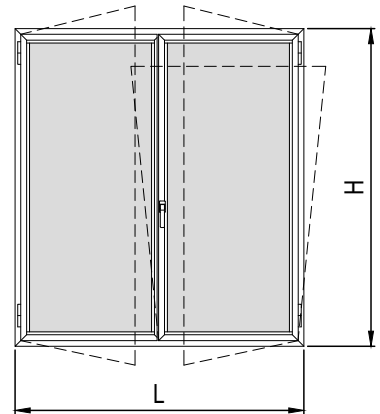

DISTINTA ACCESSORI

CODICE	DESCRIZIONE	N°
TA089	REGOLO TELAIO CAMERA SEMPLICE	TABELLA
TS204	SQUADRETTA INTERNA TELAIO	4
TS205	SQUADRETTA INTERNA ANTA	8
TS206	SQUADRETTA ESTERNA TELAIO / ANTA	20
S810	SPINA D8 PER SQUADRETTE INTERNE TELAIO / ANTA	24
S3001	SPINA D3 ACCIAIO PER SQUADRETTE ESTERNE TELAIO / ANTA	40
G266 *	SPINA D3 ALLUM. PER SQUADRETTE ESTERNE TELAIO / ANTA	
G501N	SQUADRETTA A CAMME PER TELAIO	4
TT067	TAPPO ANTERIORE TZ CE	1
TT041	TAPPO POSTERIORE TZ CE	1
G112	SQUADRETTA INOX DI ALLINEAMENTO ANGOLI	10
G269	SQUADRETTA ALLINEAMENTO ANTE	6
G101	CAPPETTA DRENAGGIO ACQUA	2 ... 3
* IN ALTERNATIVA		

N.B. : PER GLI ACCESSORI DI CHIUSURA, MOVIMENTAZIONE E LIMITI PRESTAZIONALI CONSULTARE IL MANUALE DEL FORNITORE DEGLI ACCESSORI.

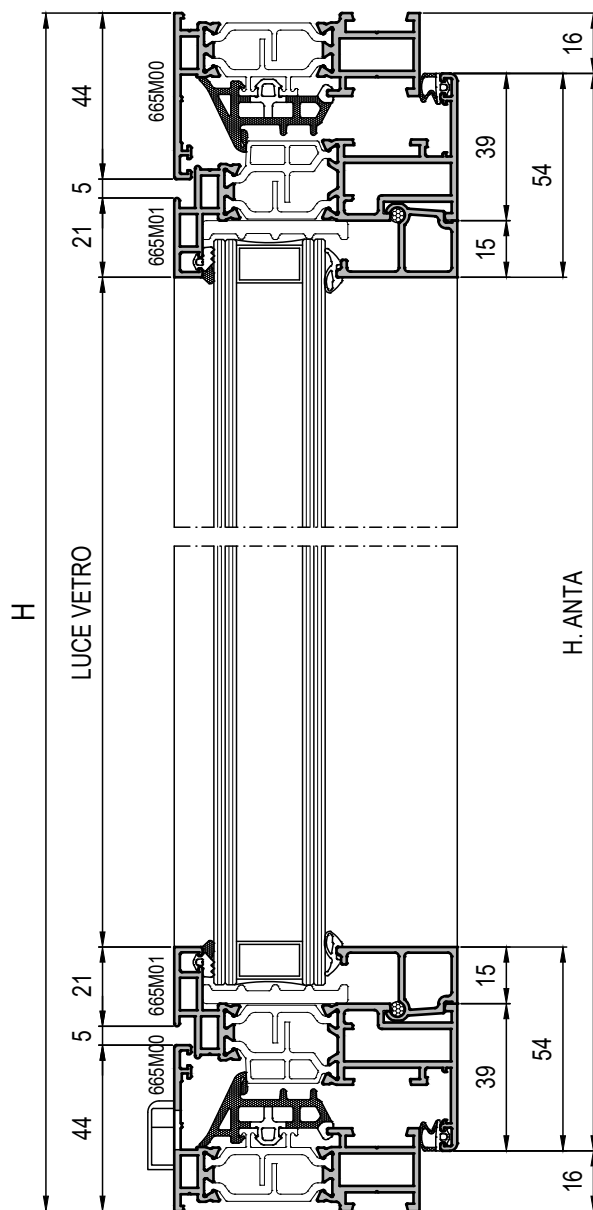
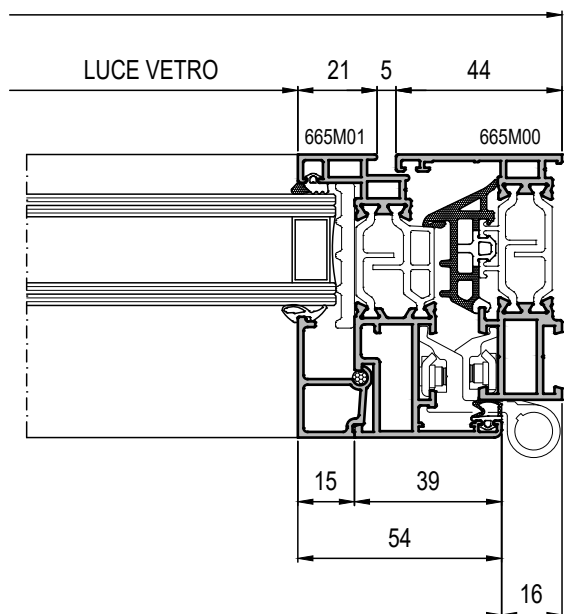

DISTINTA GUARNIZIONI

CODICE	DESCRIZIONE	N°
TG176	ANGOLO VULCANIZZATO	4 Pz.
TG175	GUARNIZIONE DI TENUTA CENTRALE	2L+3H
TG031	GUARNIZIONE DI BATTUTA	2L+4H
	GUARNIZIONE CINGIVETRO ESTERNA	2L+4H
	GUARNIZIONE CINGIVETRO INTERNA	2L+4H
TG307	SOTTOVETRO ISOLANTE	2L+4H
Z119	GUARNIZIONE ISOLANTE	L+2H
* IN ALTERNATIVA		

PORTA FINESTRA A DUE ANTE GIUNTO APERTO APERTURA INTERNA CAMERA EUROPEA CON SOGLIA RIBASSATA

DISTINTA PROFILATI

CODICE	PROFILATO	DESCRIZIONE	MISURA TAGLIO	TAGLIO	N°
665M00		TELAIO Z	L		1
			H		2
665M01		ANTA Z CAMERA EUROPEA	(L/2) - 7.5		4
			H - 23.4		3
665M02		ANTA T CAMERA EUROPEA	H - 1.4		1
665M07		TRAVERSO PER ANTA	LANTA - 68		2
665M08		ZOCCOLO RIP. ANTA	LANTA - 68		2
665087		SOGLIA RIBASSATA	L - 24		1
665332		FERMAVETRO	(L/2) - 85.5		8
			H1 - 112.4		4
			H2 - 96		4
6405		ASTINA DI COMANDO	DIPENDE DA ACCESSORIO DI COMANDO		DIPENDE DA ACCESSORIO DI COMANDO

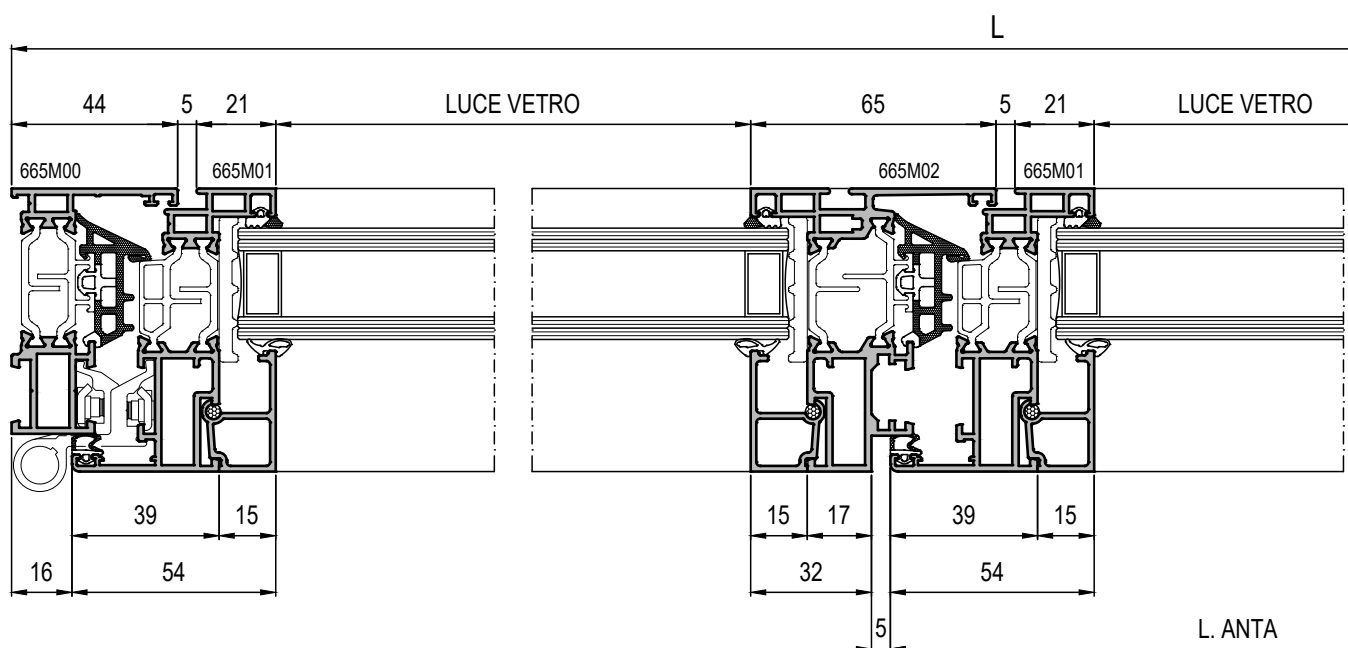
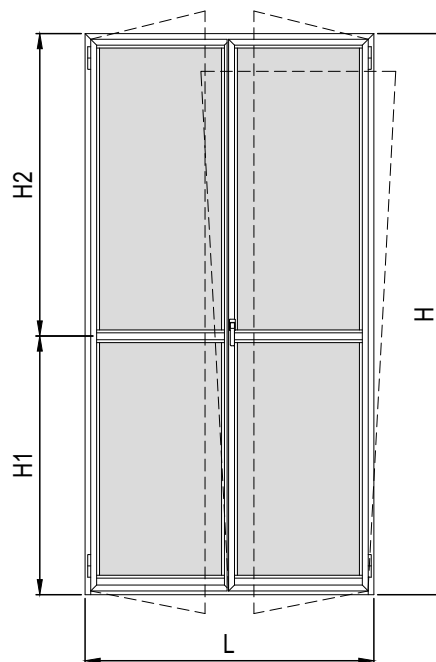

DISTINTA ACCESSORI

CODICE	DESCRIZIONE	N°
TA089	REGOLO TELAIO CAMERA SEMPLICE	TABELLA
TS204	SQUADRETTA INTERNA TELAIO	2
TS205	SQUADRETTA INTERNA ANTA	8
TS206	SQUADRETTA ESTERNA TELAIO / ANTA	18
S810	SPINA D8 PER SQUADRETTE INTERNE TELAIO / ANTA	20
S3001	SPINA D3 ACCIAIO PER SQUADRETTE ESTERNE TELAIO / ANTA	36
G266 *	SPINA D3 ALLUM. PER SQUADRETTE ESTERNE TELAIO / ANTA	
G501N	SQUADRETTA A CAMME PER TELAIO	4
TT067	TAPPO ANTERIORE TZ CE	1
TT041	TAPPO POSTERIORE TZ CE	1
GT118	TAPPO GOCCIOLATOIO	1
G112	SQUADRETTA INOX DI ALLINEAMENTO ANGOLI	10
G269	SQUADRETTA ALLINEAMENTO ANTE	6
G101	CAPPETTA DRENAGGIO ACQUA	2 ... 3
TS091	CAVALLOTTO ESTERNO PER TRAVERSO	4
TS090	CAVALLOTTO INTERNO PER TRAVERSO	4

* IN ALTERNATIVA

N.B. : PER GLI ACCESSORI DI CHIUSURA, MOVIMENTAZIONE E LIMITI PRESTAZIONALI CONSULTARE IL MANUALE DEL FORNITORE DEGLI ACCESSORI.

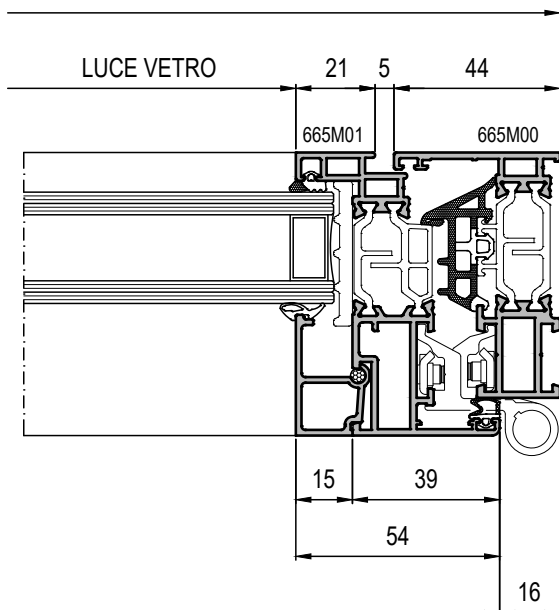
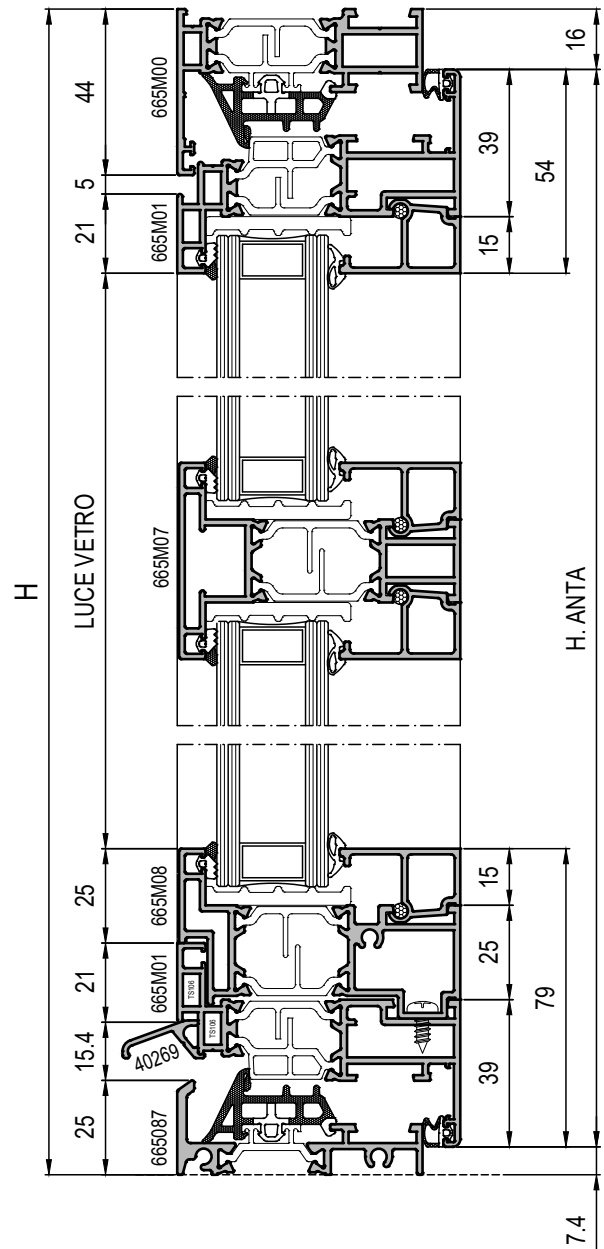

DISTINTA GUARNIZIONI

CODICE	DESCRIZIONE	N°
TG176	ANGOLO VULCANIZZATO	4 Pz.
TG175	GUARNIZIONE DI TENUTA CENTRALE	2L+3H
TG031	GUARNIZIONE DI BATTUTA	2L+4H
	GUARNIZIONE CINGIVETRO ESTERNA	2L+4H
	GUARNIZIONE CINGIVETRO INTERNA	2L+4H
TG307	SOTTOVETRO ISOLANTE	2L+4H
Z119	GUARNIZIONE ISOLANTE	L+2H

* IN ALTERNATIVA

FINESTRA AD UN' ANTA GIUNTO APERTO APERTURA INTERNA PISTA 16

DISTINTA PROFILATI

CODICE	PROFILATO	DESCRIZIONE	MISURA TAGLIO	TAGLIO	N°
665M00		TELAIO L	L		2
			H		2
665M03		ANTA Z PISTA 16	L - 32		2
			H - 32		2
665332		FERMAVETRO	L - 125		2
			H - 155		2

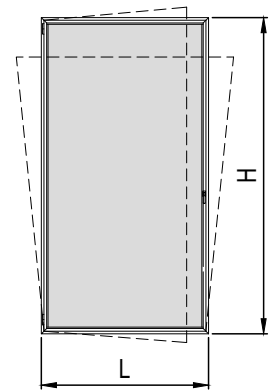

VISTA INTERNA

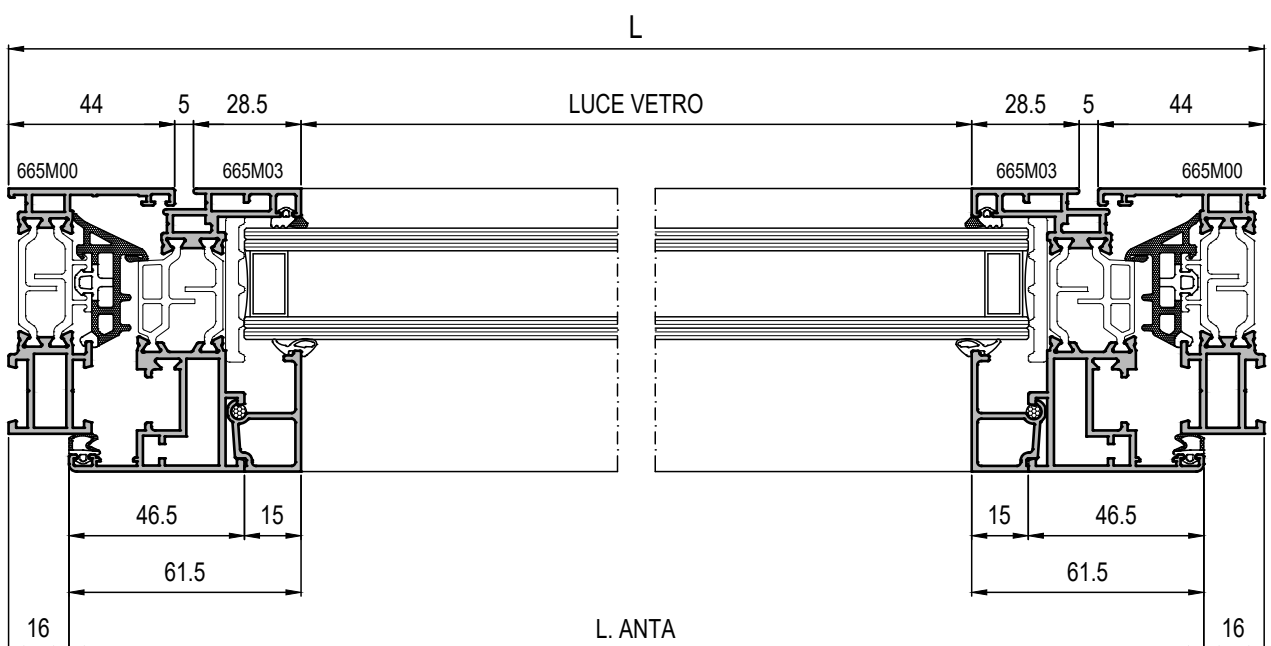

DISTINTA ACCESSORI

CODICE	DESCRIZIONE	N°
TA089	REGOLO TELAIO CAMERA SEMPLICE	TABELLA
TS204	SQUADRETTA INTERNA TELAIO	4
TS205	SQUADRETTA INTERNA ANTA	4
TS206	SQUADRETTA ESTERNA TELAIO / ANTA	12
S810	SPINA D8 PER SQUADRETTE INTERNE TELAIO / ANTA	16
S3001	SPINA D3 ACCIAIO PER SQUADRETTE ESTERNE TELAIO / ANTA	24
G266 *	SPINA D3 ALLUM. PER SQUADRETTE ESTERNE TELAIO / ANTA	
G501N	SQUADRETTA A CAMME PER TELAIO	4
G112	SQUADRETTA INOX DI ALLINEAMENTO ANGOLI	8
G101	CAPPETTA DRENAGGIO ACQUA	2 ... 3
* IN ALTERNATIVA		

N.B. : PER GLI ACCESSORI DI CHIUSURA, MOVIMENTAZIONE E LIMITI PRESTAZIONALI CONSULTARE IL MANUALE DEL FORNITORE DEGLI ACCESSORI.





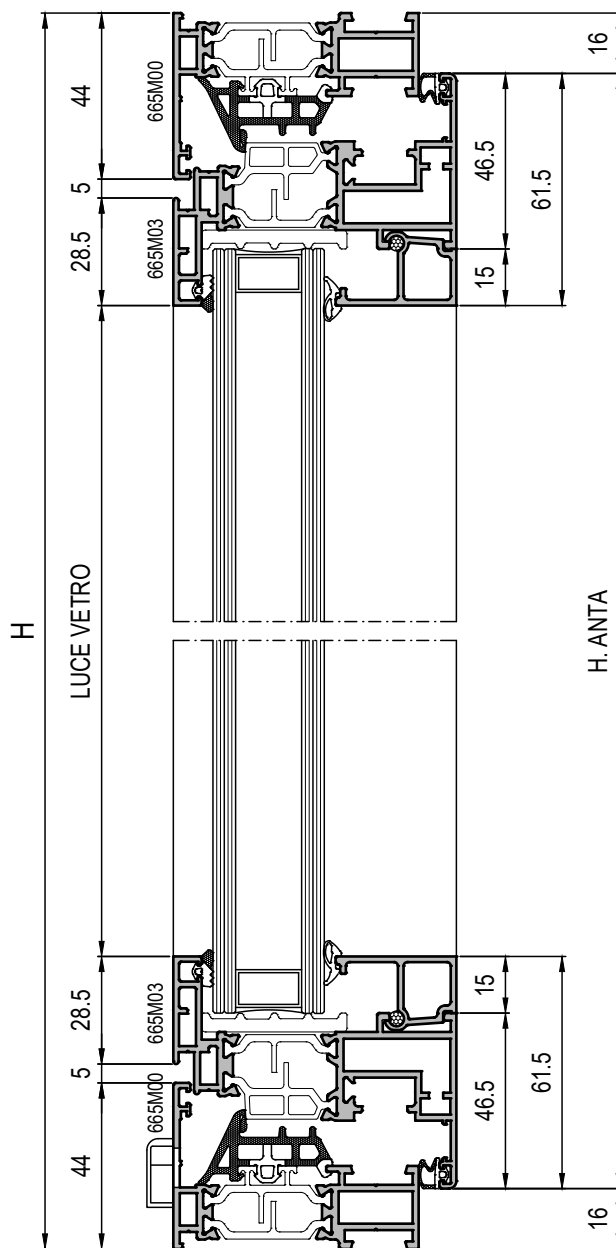



DISTINTA GUARNIZIONI

CODICE	DESCRIZIONE	N°
TG176	ANGOLO VULCANIZZATO	4 Pz.
TG175	GUARNIZIONE DI TENUTA CENTRALE	2L+2H
TG031	GUARNIZIONE DI BATTUTA	2L+2H
	GUARNIZIONE CINGIVETRO ESTERNA	2L+2H
	GUARNIZIONE CINGIVETRO INTERNA	2L+2H
TG307	SOTTOVETRO ISOLANTE	2L+2H
Z119	GUARNIZIONE ISOLANTE	L+2H
* IN ALTERNATIVA		



FINESTRA A DUE ANTE GIUNTO APERTO APERTURA INTERNA PISTA 16

DISTINTA PROFILATI

CODICE	PROFILATO	DESCRIZIONE	MISURA TAGLIO	TAGLIO	N°
665M00		TELAIO Z	L		2
			H		2
665M03		ANTA Z CAMERA EUROPEA	(L/2) - 6.5		4
			H - 32		3
665M04		ANTA T CAMERA P16	H - 13.8		1
665332		FERMAVETRO	(L/2) - 99.5		4
			H - 155		4

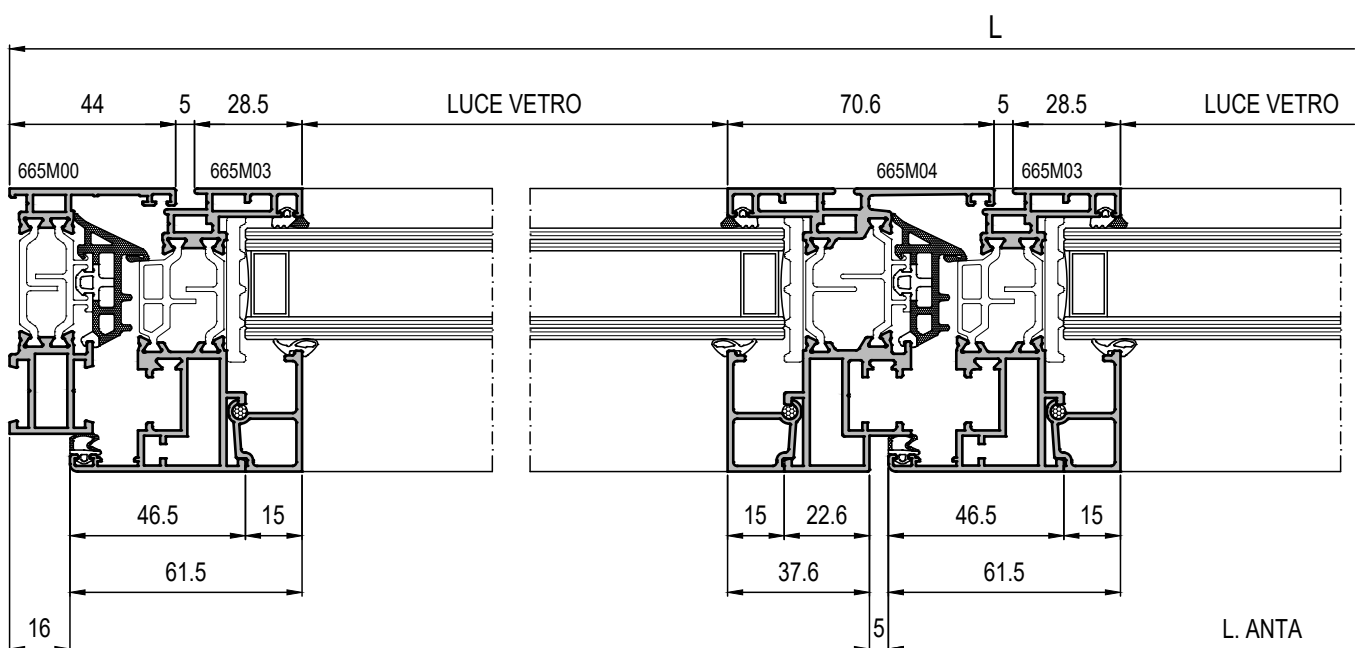
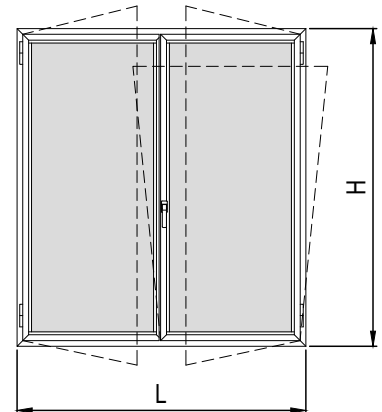

DISTINTA ACCESSORI

CODICE	DESCRIZIONE	N°
TA089	REGOLO TELAIO CAMERA SEMPLICE	TABELLA
TS204	SQUADRETTA INTERNA TELAIO	4
TS205	SQUADRETTA INTERNA ANTA	8
TS206	SQUADRETTA ESTERNA TELAIO / ANTA	20
S810	SPINA D8 PER SQUADRETTE INTERNE TELAIO / ANTA	24
S3001	SPINA D3 ACCIAIO PER SQUADRETTE ESTERNE TELAIO / ANTA	40
G266 *	SPINA D3 ALLUM. PER SQUADRETTE ESTERNE TELAIO / ANTA	
G501N	SQUADRETTA A CAMME PER TELAIO	4
TT067	TAPPO ANTERIORE TZ PISTA 16	1
TT069	TAPPO POSTERIORE TZ PISTA 16	1
G112	SQUADRETTA INOX DI ALLINEAMENTO ANGOLI	10
G101	CAPPETTA DRENAGGIO ACQUA	2 ... 3
* IN ALTERNATIVA		

N.B. : PER GLI ACCESSORI DI CHIUSURA, MOVIMENTAZIONE E LIMITI PRESTAZIONALI CONSULTARE IL MANUALE DEL FORNITORE DEGLI ACCESSORI.

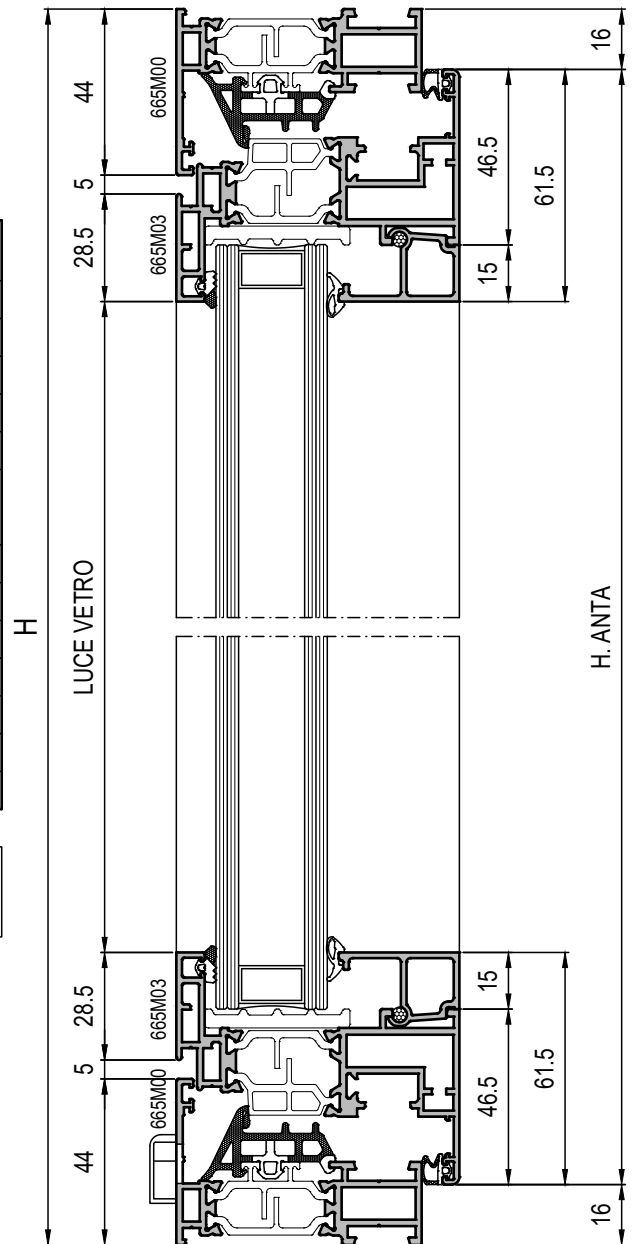
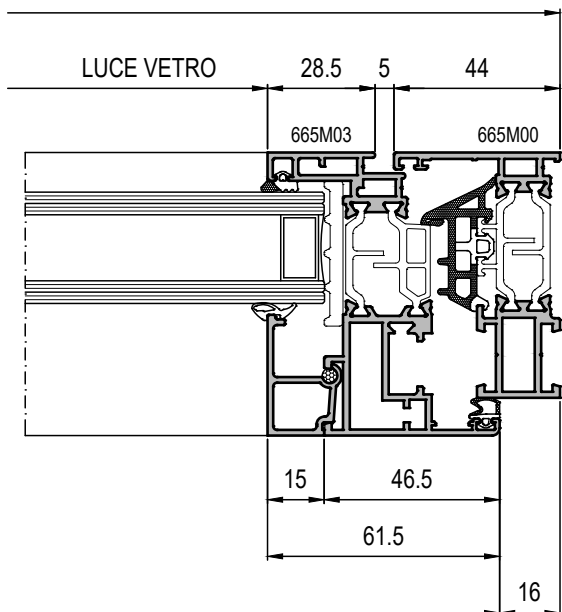



















DISTINTA GUARNIZIONI

CODICE	DESCRIZIONE	N°
TG176	ANGOLO VULCANIZZATO	4 Pz.
TG175	GUARNIZIONE DI TENUTA CENTRALE	2L+3H
TG031	GUARNIZIONE DI BATTUTA	2L+4H
	GUARNIZIONE CINGIVETRO ESTERNA	2L+4H
	GUARNIZIONE CINGIVETRO INTERNA	2L+4H
TG307	SOTTOVETRO ISOLANTE	2L+4H
Z119	GUARNIZIONE ISOLANTE	L+2H
* IN ALTERNATIVA		

PORTA FINESTRA A DUE ANTE GIUNTO APERTO APERTURA INTERNA PISTA 16 CON SOGLIA RIBASSATA

DISTINTA PROFILATI

CODICE	PROFILATO	DESCRIZIONE	MISURA TAGLIO	TAGLIO	N°
665M00		TELAIO Z	L		1
			H		2
665M03		ANTA Z PISTA 16	(L/2) - 6.5		4
			H - 23.4		3
665M04		ANTA T PISTA 16	H - 5.2		1
665M07		TRAVERSO PER ANTA	LANTA - 83		2
665M08		ZOCCOLO RIP. ANTA	LANTA - 83		2
665087		SOGLIA RIBASSATA	L - 24		1
665332		FERMAVETRO	(L/2) - 99.5		8
			H1 - 120		4
			H2 - 103.5		4

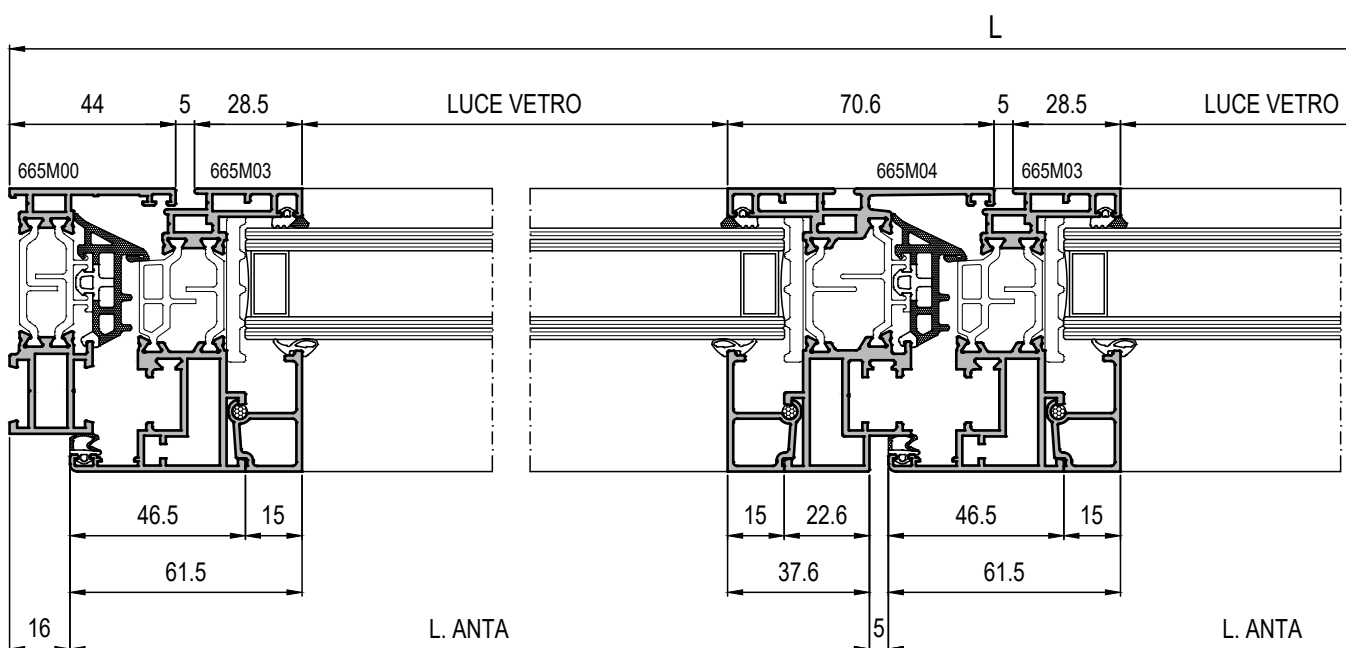
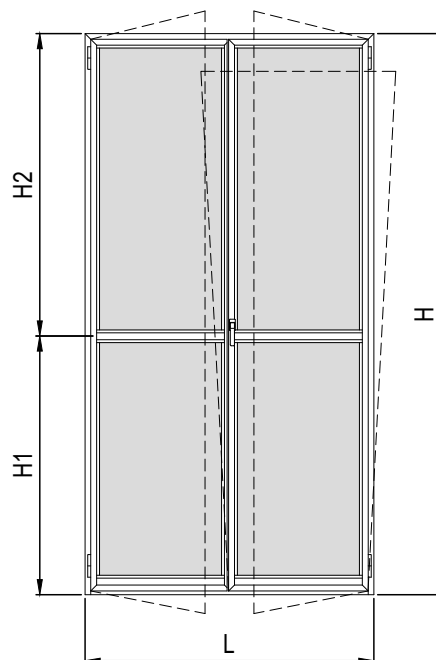

DISTINTA ACCESSORI

CODICE	DESCRIZIONE	N°
TA089	REGOLO TELAIO CAMERA SEMPLICE	TABELLA
TS204	SQUADRETTA INTERNA TELAIO	2
TS205	SQUADRETTA INTERNA ANTA	8
TS206	SQUADRETTA ESTERNA TELAIO / ANTA	18
S810	SPINA D8 PER SQUADRETTE INTERNE TELAIO / ANTA	20
S3001	SPINA D3 ACCIAIO PER SQUADRETTE ESTERNE TELAIO / ANTA	36
G266 *	SPINA D3 ALLUM. PER SQUADRETTE ESTERNE TELAIO / ANTA	
G501N	SQUADRETTA A CAMME PER TELAIO	2
TT067	TAPPO ANTERIORE TZ PISTA 16	1
TT069	TAPPO POSTERIORE TZ PISTA 16	1
GT118	TAPPO GOCCIOLATOIO	1
G112	SQUADRETTA INOX DI ALLINEAMENTO ANGOLI	10
G101	CAPPETTA DRENAGGIO ACQUA	2 ... 3
TS091	CAVALLOTTO ESTERNO PER TRAVERSO	4
TS090	CAVALLOTTO INTERNO PER TRAVERSO	4

* IN ALTERNATIVA

N.B. : PER GLI ACCESSORI DI CHIUSURA, MOVIMENTAZIONE E LIMITI PRESTAZIONALI CONSULTARE IL MANUALE DEL FORNITORE DEGLI ACCESSORI.

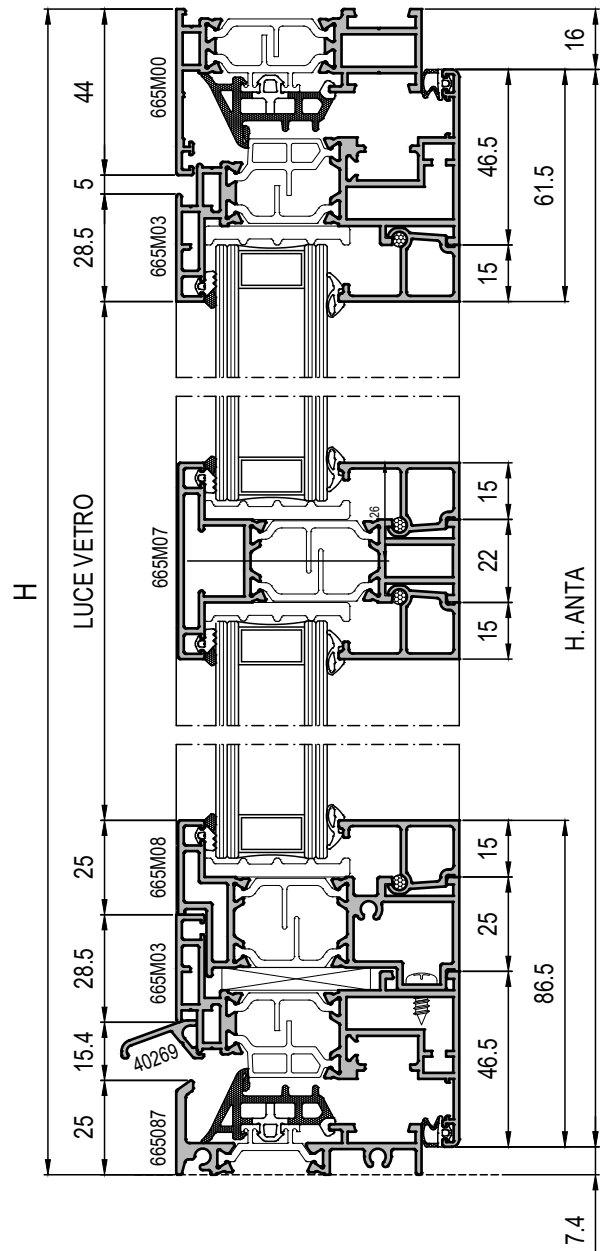
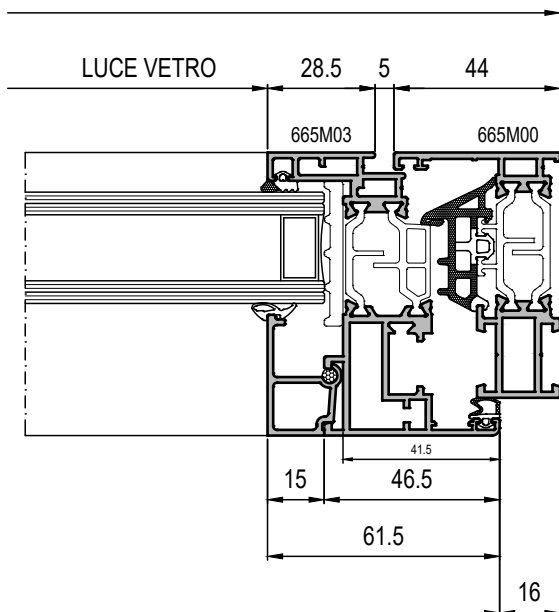

DISTINTA GUARNIZIONI

CODICE	DESCRIZIONE	N°
TG176	ANGOLO VULCANIZZATO	4 Pz.
TG175	GUARNIZIONE DI TENUTA CENTRALE	2L+3H
TG031	GUARNIZIONE DI BATTUTA	2L+4H
	GUARNIZIONE CINGIVETRO ESTERNA	2L+4H
	GUARNIZIONE CINGIVETRO INTERNA	2L+4H
TG307	SOTTOVETRO ISOLANTE	2L+4H
Z119	GUARNIZIONE ISOLANTE	L+2H

* IN ALTERNATIVA

FINESTRA AD UN' ANTA A SCOMPARSA GIUNTO APERTO APERTURA INTERNA CAMERA EUROPEA

DISTINTA PROFILATI

CODICE	PROFILATO	DESCRIZIONE	MISURA TAGLIO	TAGLIO	N°
665M09		TELAIO L	L		2
			H		2
665M01		ANTA Z CAMERA EUROPEA	L - 32		2
			H - 32		2
665332		FERMAVETRO	L - 110		2
			H - 140		2
6405		ASTINA DI COMANDO	DIPENDE DA ACCESSORIO DI COMANDO		DIPENDE DA ACCESSORIO DI COMANDO

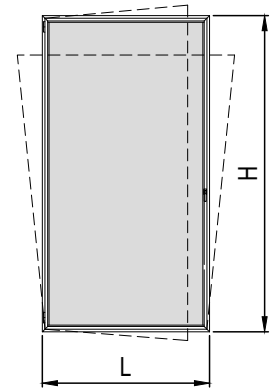

VISTA INTERNA

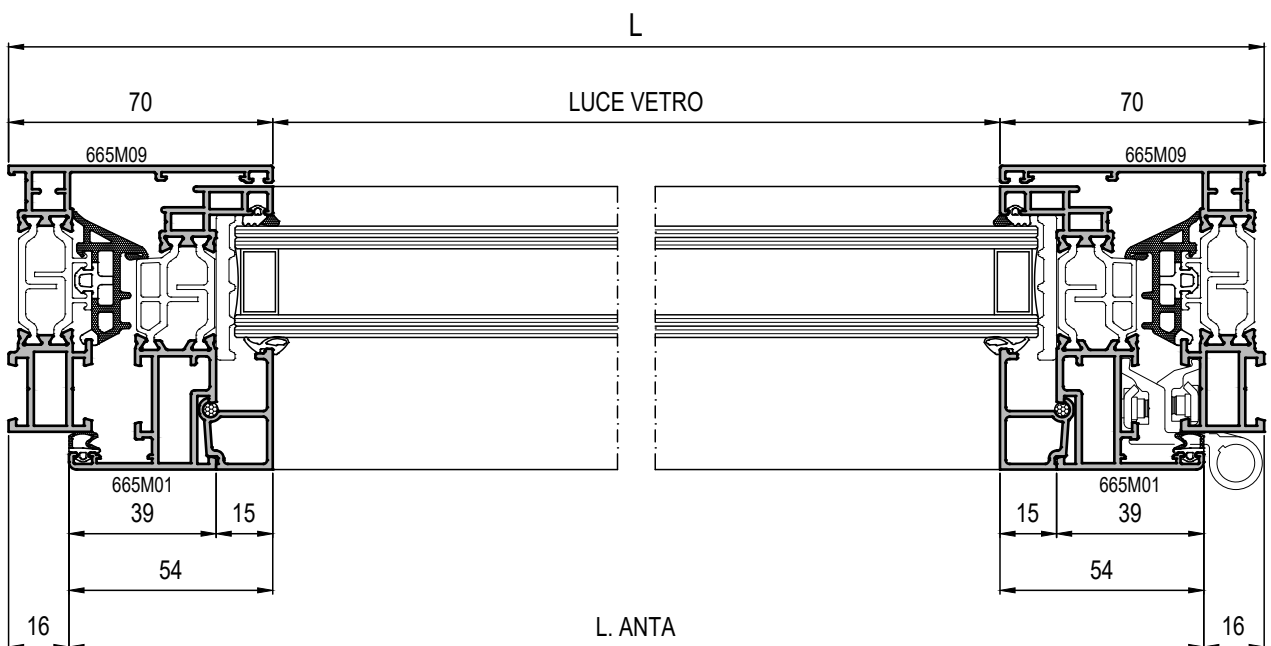

DISTINTA ACCESSORI

CODICE	DESCRIZIONE	N°
TA089	REGOLO TELAIO CAMERA SEMPLICE	TABELLA
TS204	SQUADRETTA INTERNA TELAIO	4
TS205	SQUADRETTA INTERNA ANTA	4
TS206	SQUADRETTA ESTERNA TELAIO / ANTA	16
S810	SPINA D8 PER SQUADRETTE INTERNE TELAIO / ANTA	16
S3001	SPINA D3 ACCIAIO PER SQUADRETTE ESTERNE TELAIO / ANTA	32
G266 *	SPINA D3 ALLUM. PER SQUADRETTE ESTERNE TELAIO / ANTA	
G501N	SQUADRETTA A CAMME PER TELAIO	4
G112	SQUADRETTA INOX DI ALLINEAMENTO ANGOLI	8
G269	SQUADRETTA ALLINEAMENTO ANTE	4
G101	CAPPETTA DRENAGGIO ACQUA	2 ... 3
* IN ALTERNATIVA		

N.B. : PER GLI ACCESSORI DI CHIUSURA, MOVIMENTAZIONE E LIMITI PRESTAZIONALI CONSULTARE IL MANUALE DEL FORNITORE DEGLI ACCESSORI.

DISTINTA GUARNIZIONI



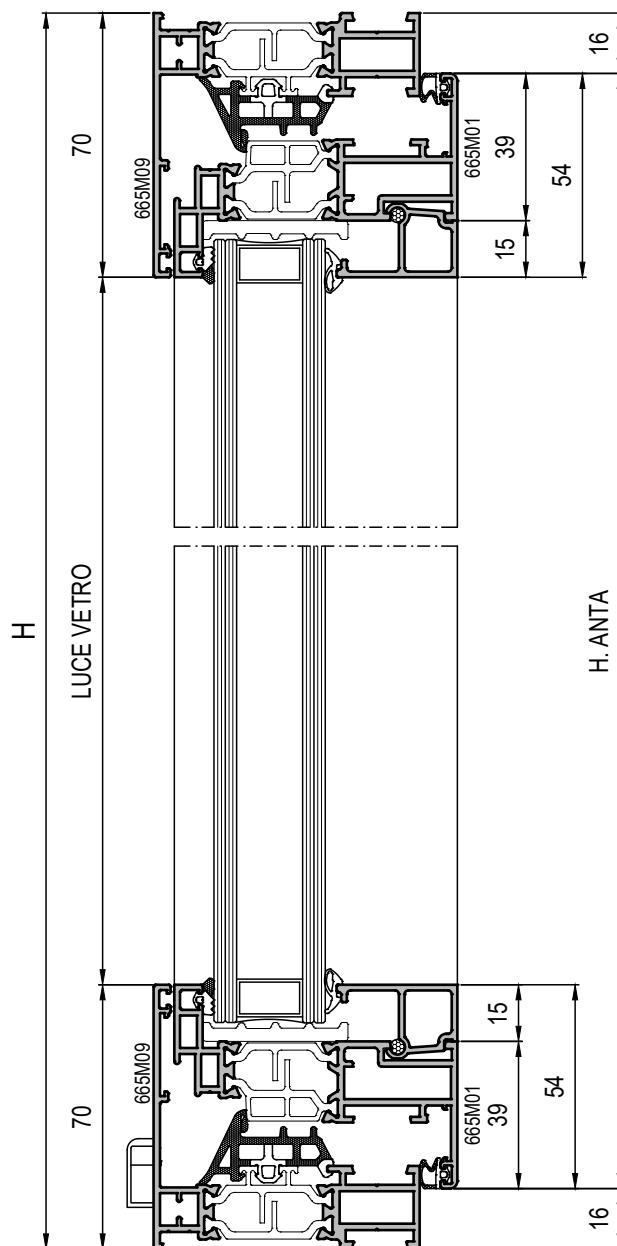









CODICE	DESCRIZIONE	N°
TG176	ANGOLO VULCANIZZATO	4 Pz.
TG175	GUARNIZIONE DI TENUTA CENTRALE	2L+2H
TG031	GUARNIZIONE DI BATTUTA	2L+2H
	GUARNIZIONE CINGIVETRO ESTERNA	2L+2H
	GUARNIZIONE CINGIVETRO INTERNA	2L+2H
TG307	SOTTOVETRO ISOLANTE	2L+2H
Z119	GUARNIZIONE ISOLANTE	L+2H
* IN ALTERNATIVA		



FINESTRA A DUE ANTE A SCOMPARSA

GIUNTO APERTO APERTURA INTERNA CAMERA EUROPEA

DISTINTA PROFILATI

CODICE	PROFILATO	DESCRIZIONE	MISURA TAGLIO	TAGLIO	N°
665M09		TELAIO Z	L		2
			H		2
665M01		ANTA Z CAMERA EUROPEA	(L/2) - 18.5		4
			H - 32		4
665M10		RIPORTO CENTRALE	H - 150		1
665332		FERMAVETRO	(L/2) - 96.5		4
			H - 140		4
6405		ASTINA DI COMANDO	DIPENDE DA ACCESSORIO DI COMANDO		DIPENDE DA ACCESSORIO DI COMANDO

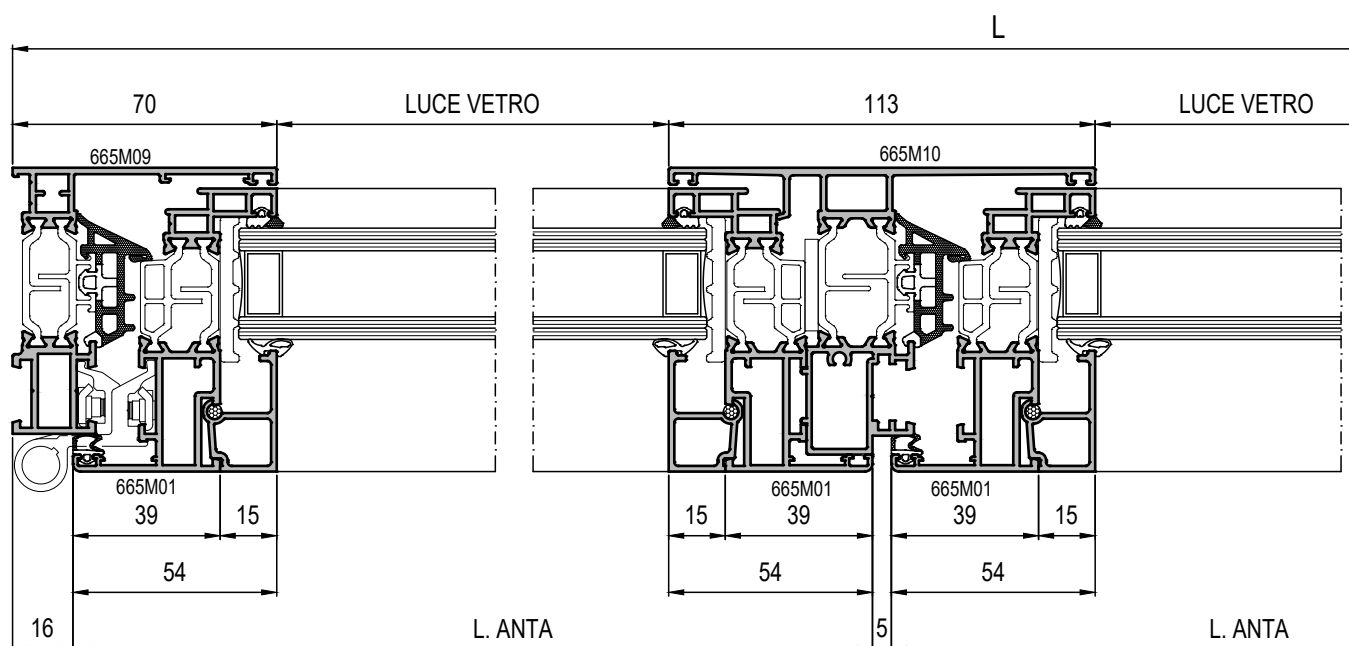
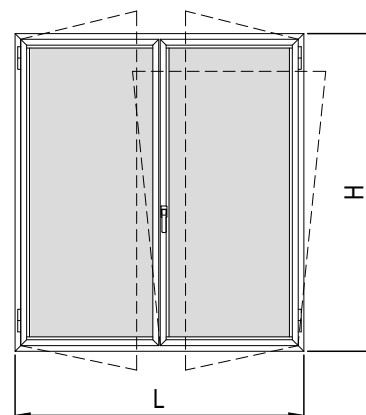

DISTINTA ACCESSORI

CODICE	DESCRIZIONE	N°
TA089	REGOLO TELAIO CAMERA SEMPLICE	TABELLA
TS204	SQUADRETTA INTERNA TELAIO	4
TS205	SQUADRETTA INTERNA ANTA	8
TS206	SQUADRETTA ESTERNA TELAIO / ANTA	24
S810	SPINA D8 PER SQUADRETTE INTERNE TELAIO / ANTA	24
S3001	SPINA D3 ACCIAIO PER SQUADRETTE ESTERNE TELAIO / ANTA	48
G266 *	SPINA D3 ALLUM. PER SQUADRETTE ESTERNE TELAIO / ANTA	
G501N	SQUADRETTA A CAMME PER TELAIO	4
TT089	TAPPO RIPORTO CENTRALE	1
G112	SQUADRETTA INOX DI ALLINEAMENTO ANGOLI	10
G269	SQUADRETTA ALLINEAMENTO ANTE	6
G101	CAPPETTA DRENAGGIO ACQUA	2 ... 3
* IN ALTERNATIVA		

N.B. : PER GLI ACCESSORI DI CHIUSURA, MOVIMENTAZIONE E LIMITI PRESTAZIONALI CONSULTARE IL MANUALE DEL FORNITORE DEGLI ACCESSORI.

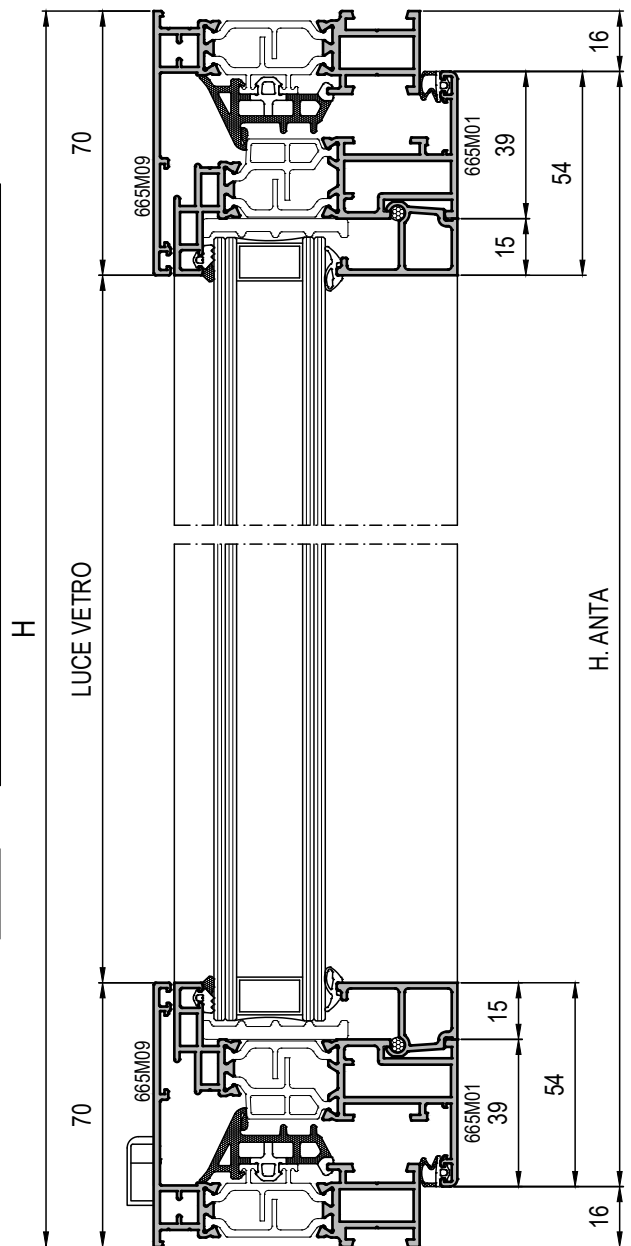
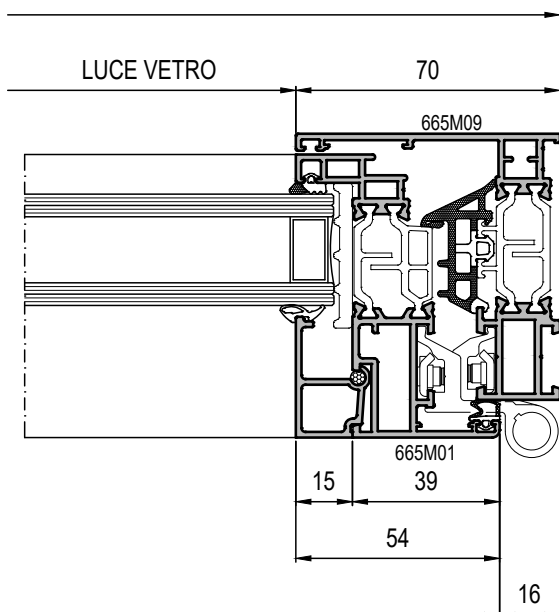

DISTINTA GUARNIZIONI

CODICE	DESCRIZIONE	N°
TG176	ANGOLO VULCANIZZATO	4 Pz.
TG175	GUARNIZIONE DI TENUTA CENTRALE	2L+3H
TG031	GUARNIZIONE DI BATTUTA	2L+4H
	GUARNIZIONE CINGIVETRO ESTERNA	2L+4H
	GUARNIZIONE CINGIVETRO INTERNA	2L+4H
TG307	SOTTOVETRO ISOLANTE	2L+4H
Z119	GUARNIZIONE ISOLANTE	L+2H
* IN ALTERNATIVA		



Nodi Scala 1:1 

FISSO

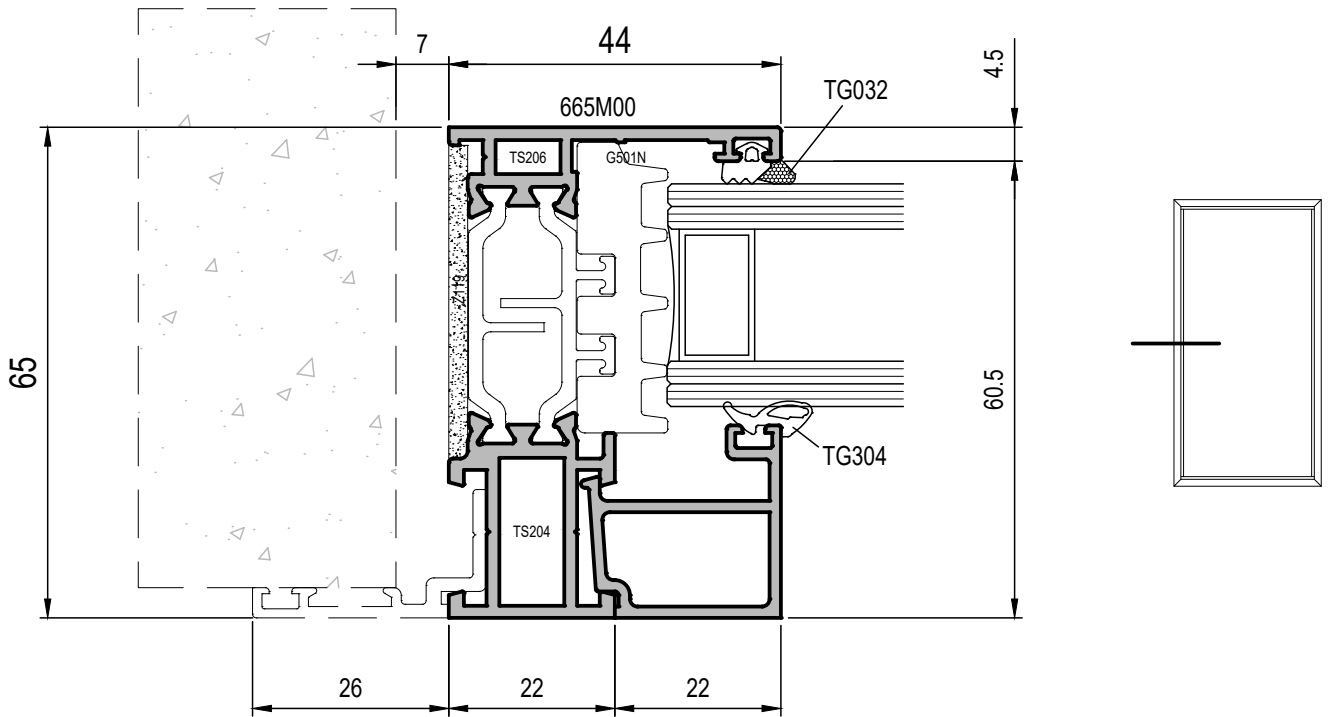

APERTURA INTERNA

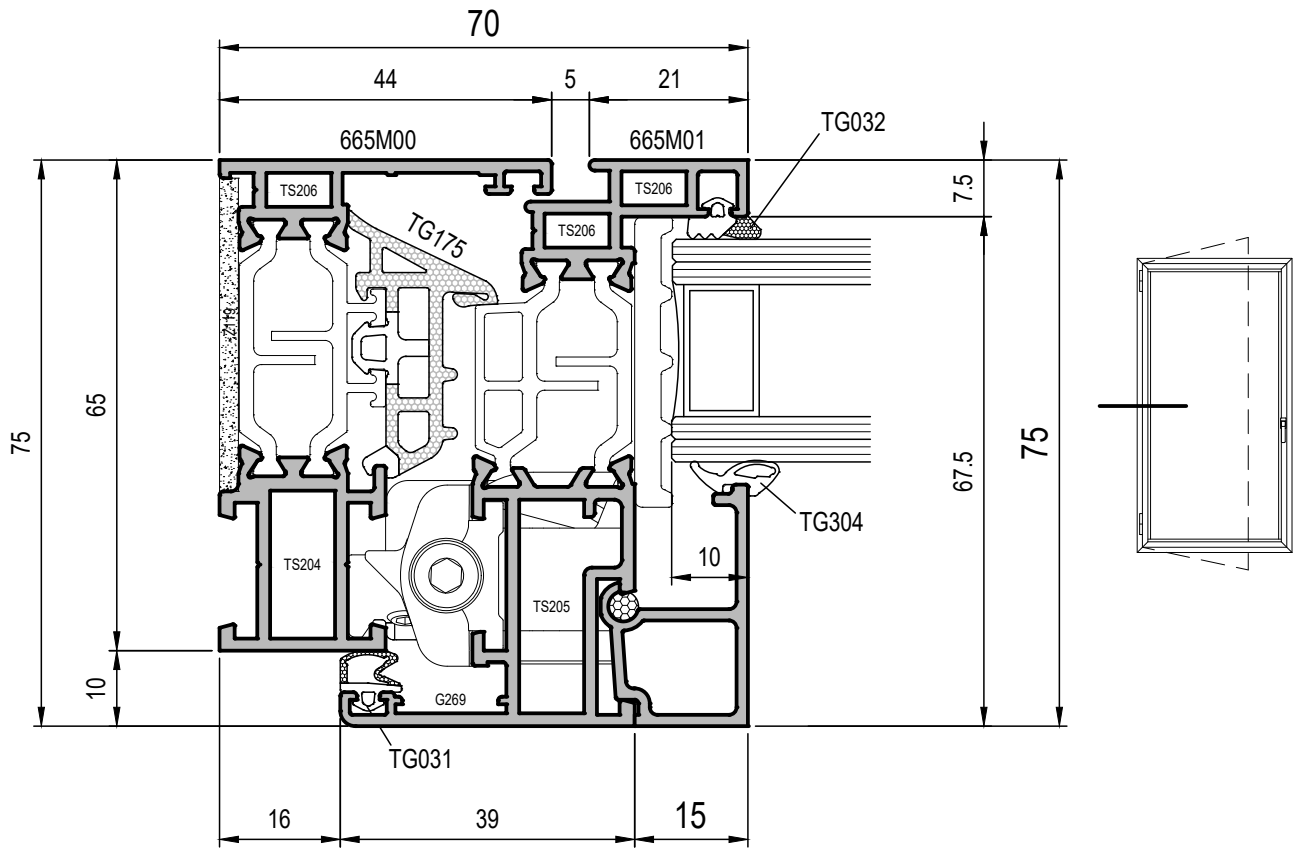

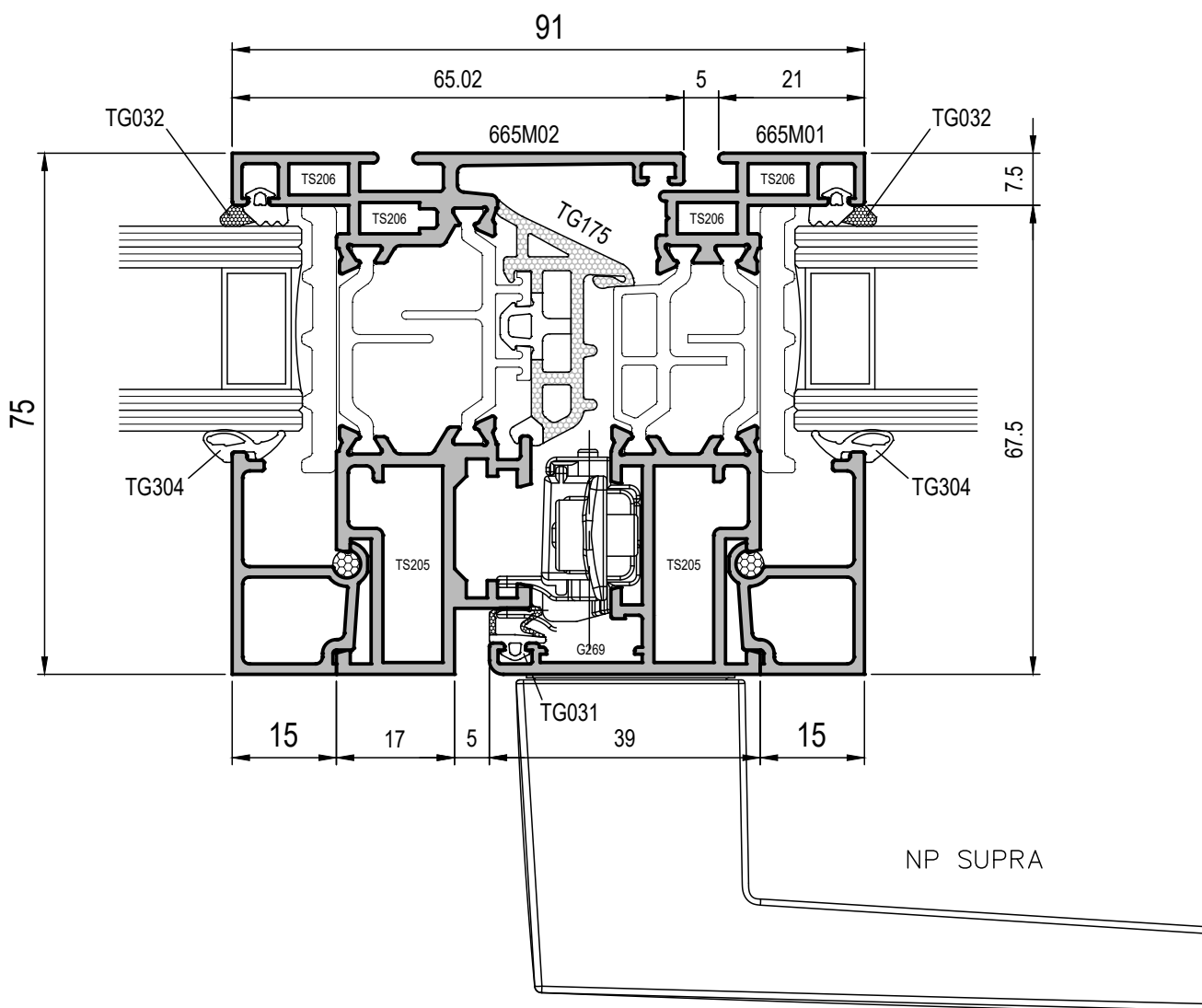
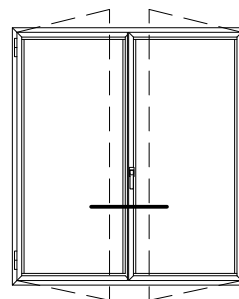

FERRAMENTA FAPIM

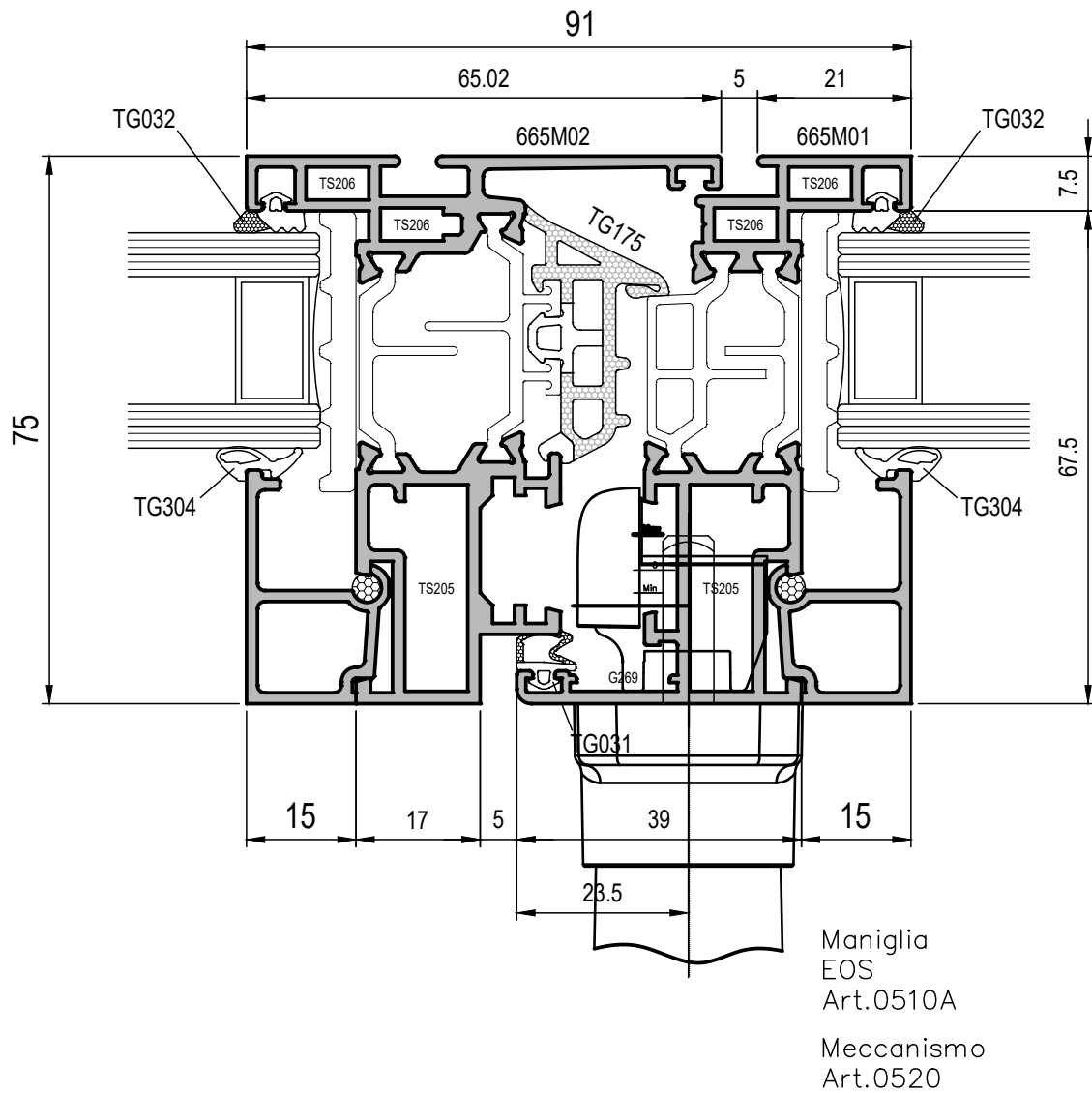
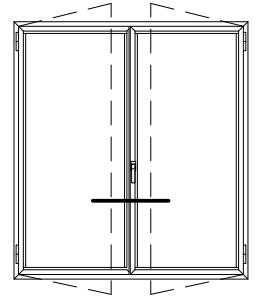

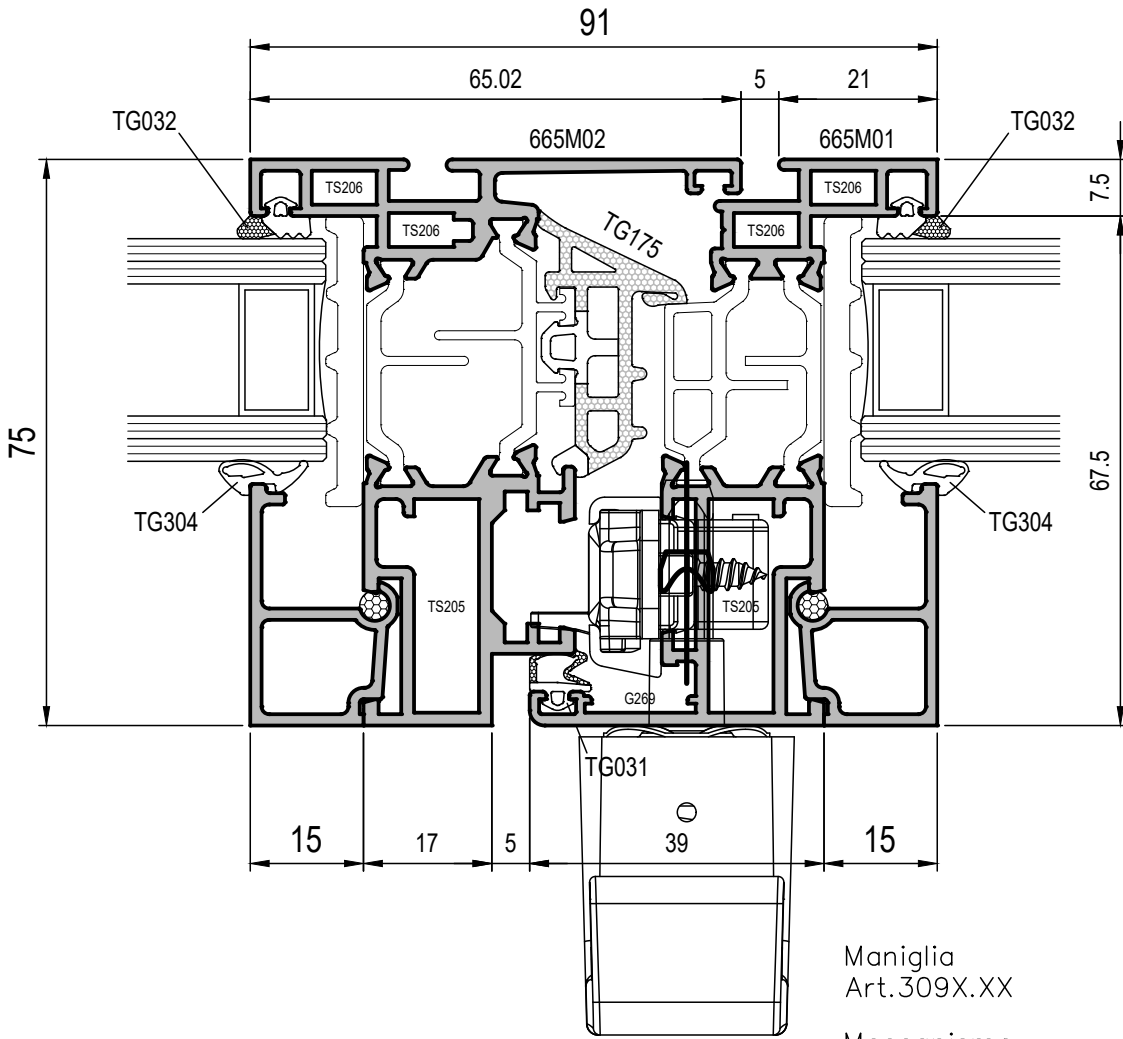
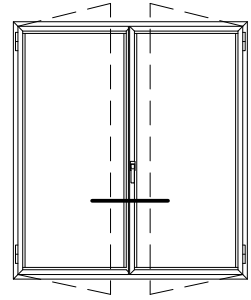

Maniglia
Art.309X.XX

Meccanismo
Art.3636.XX

INFERIORE CAMERA EUROPEA

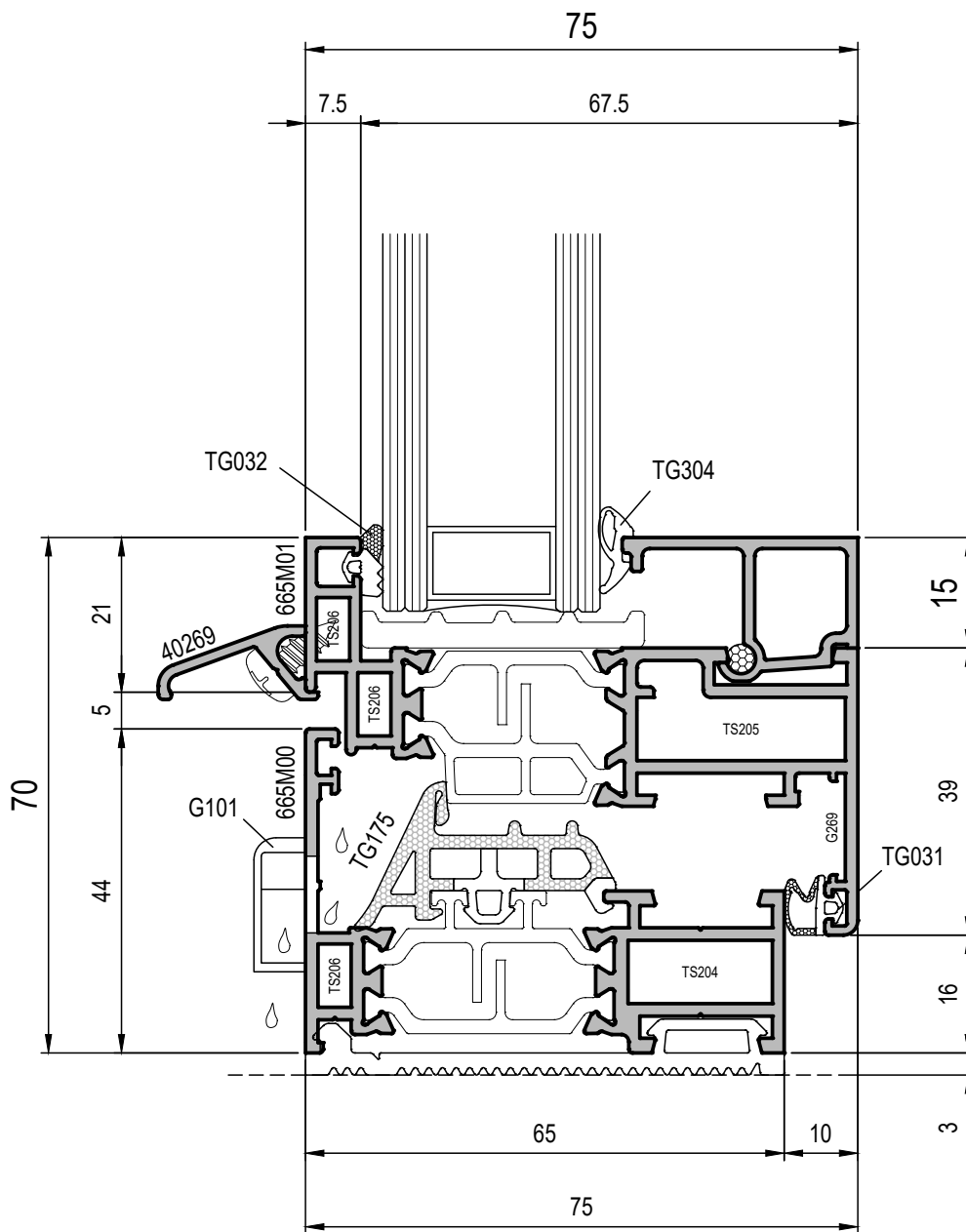
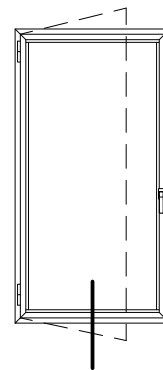

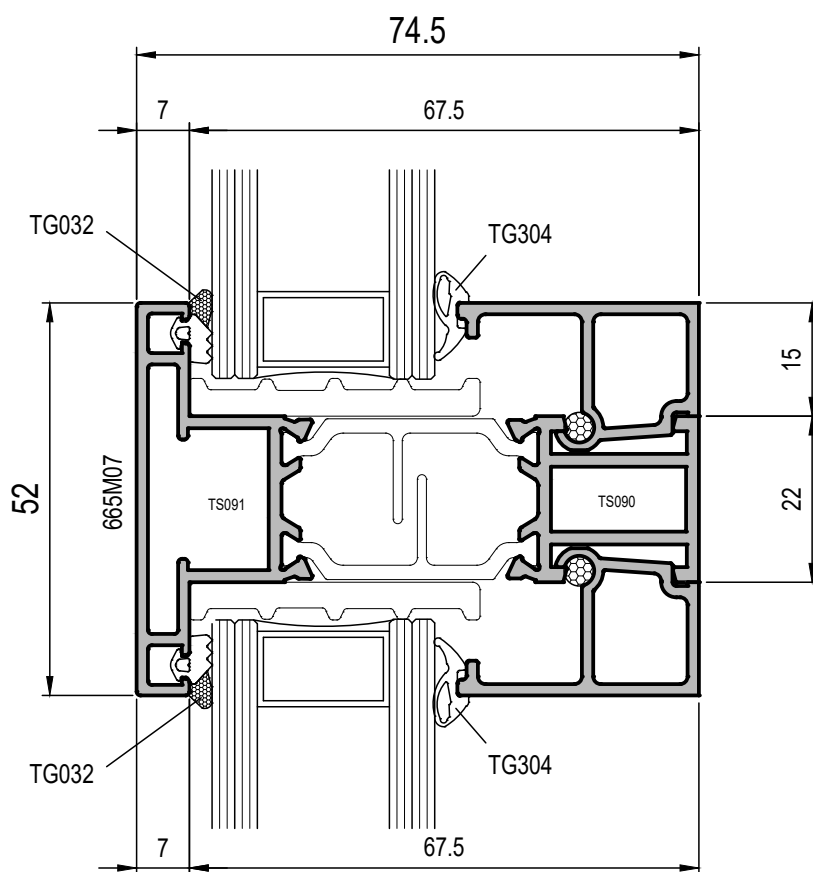
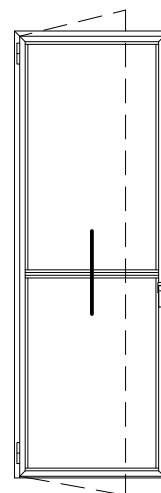

INFERIORE CON ZOCCOLO RIPORTATO E SOGLIA RIBASSATA

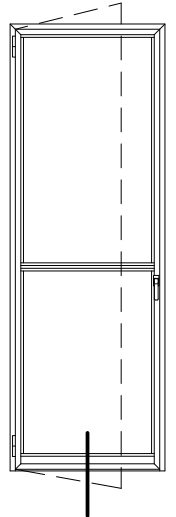
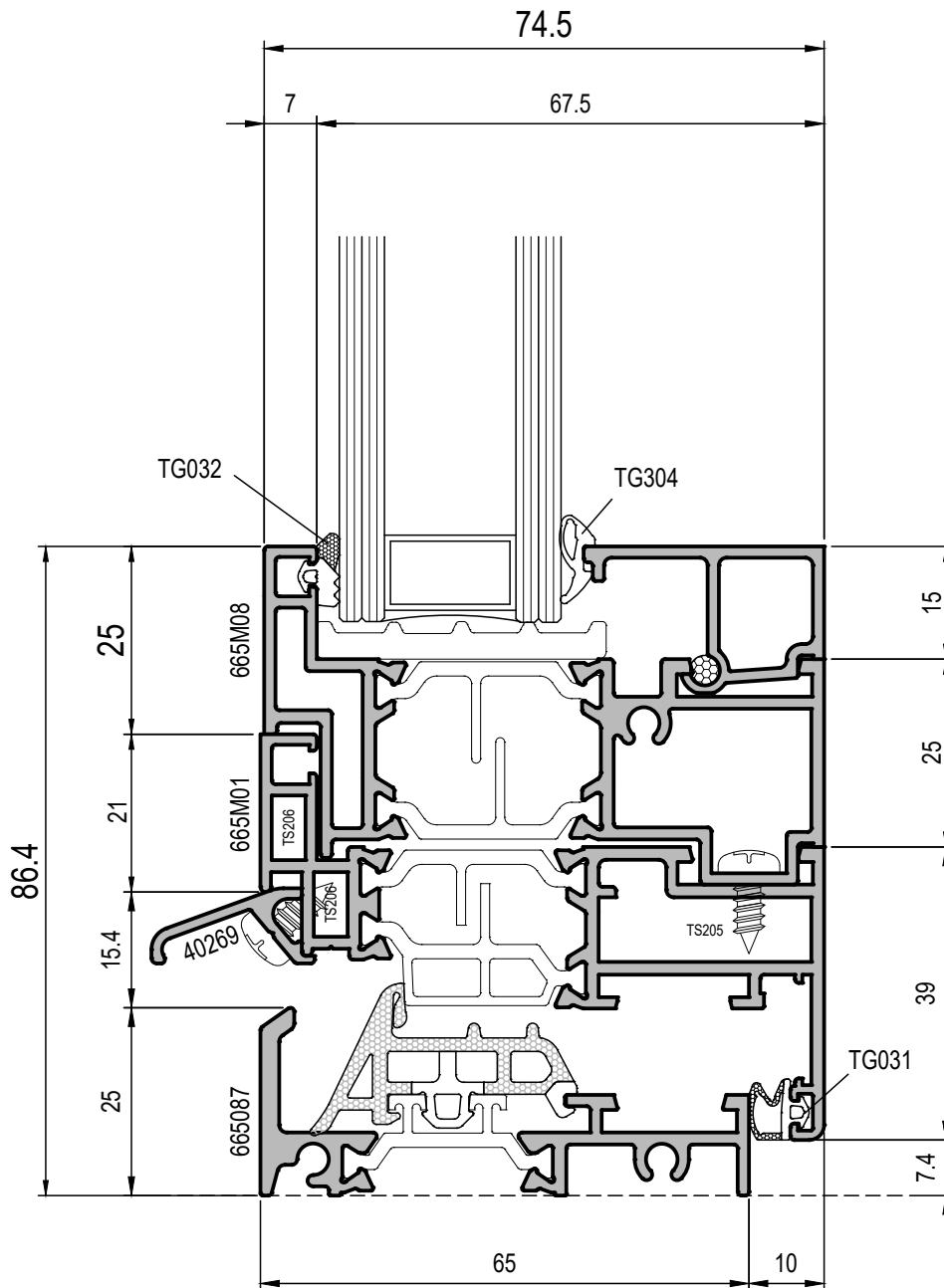

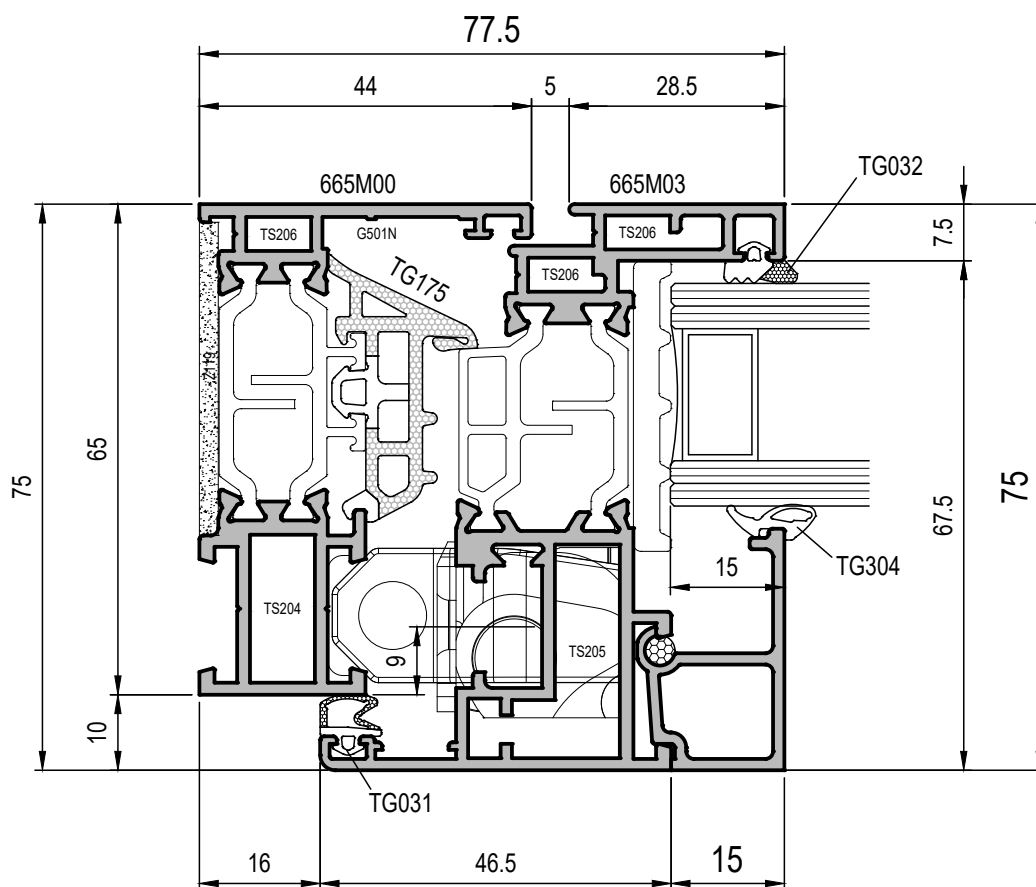
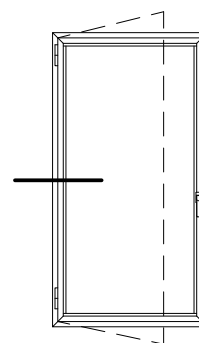

INFERIORE PISTA 16 INT.9

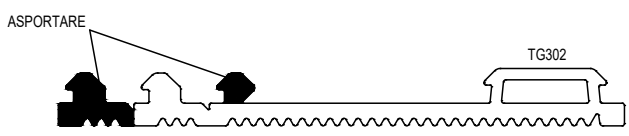
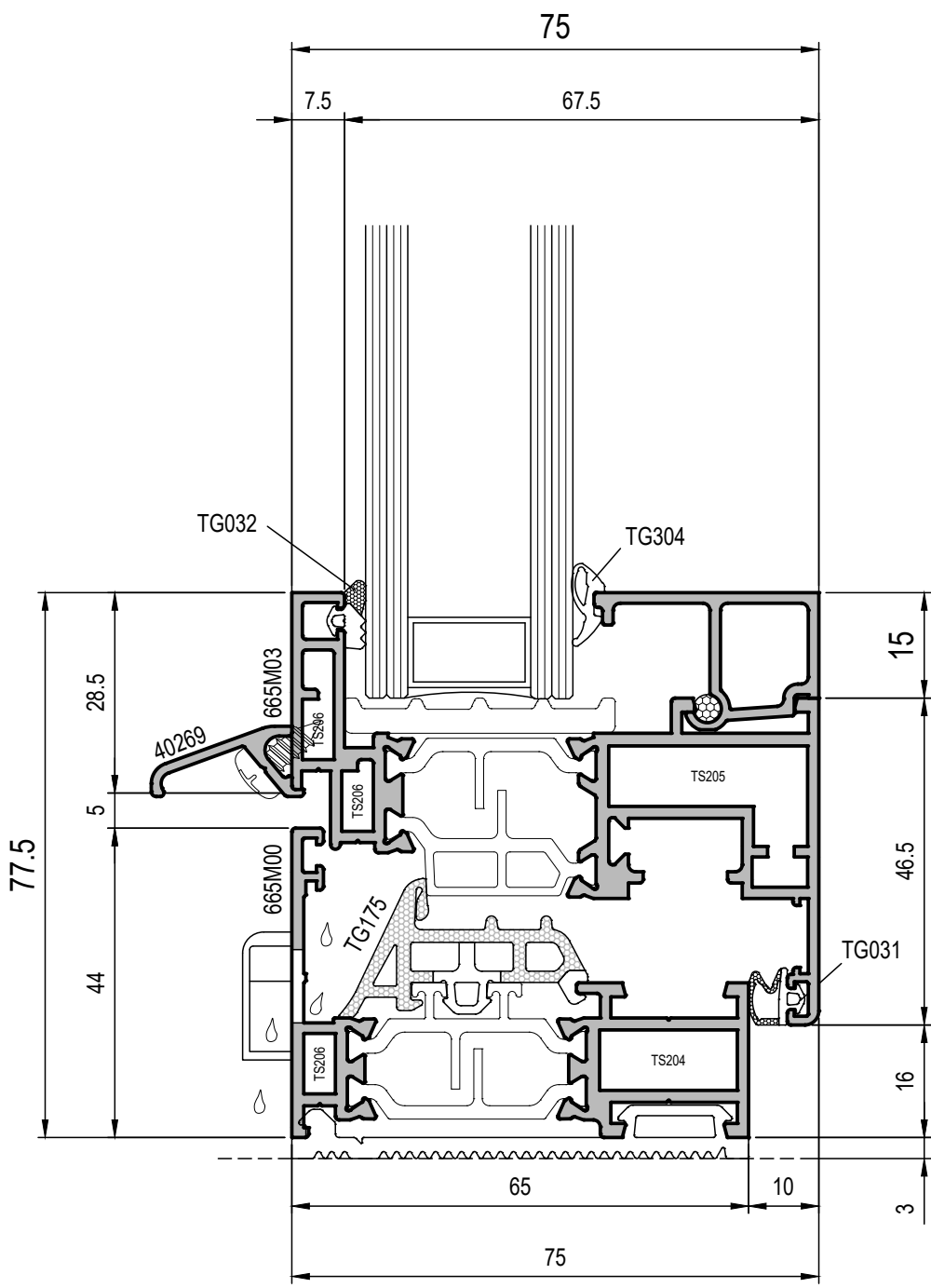
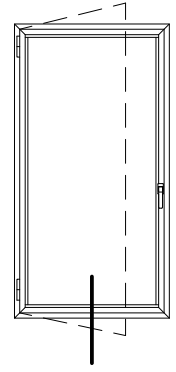



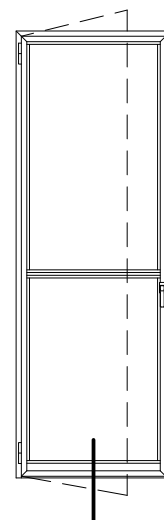
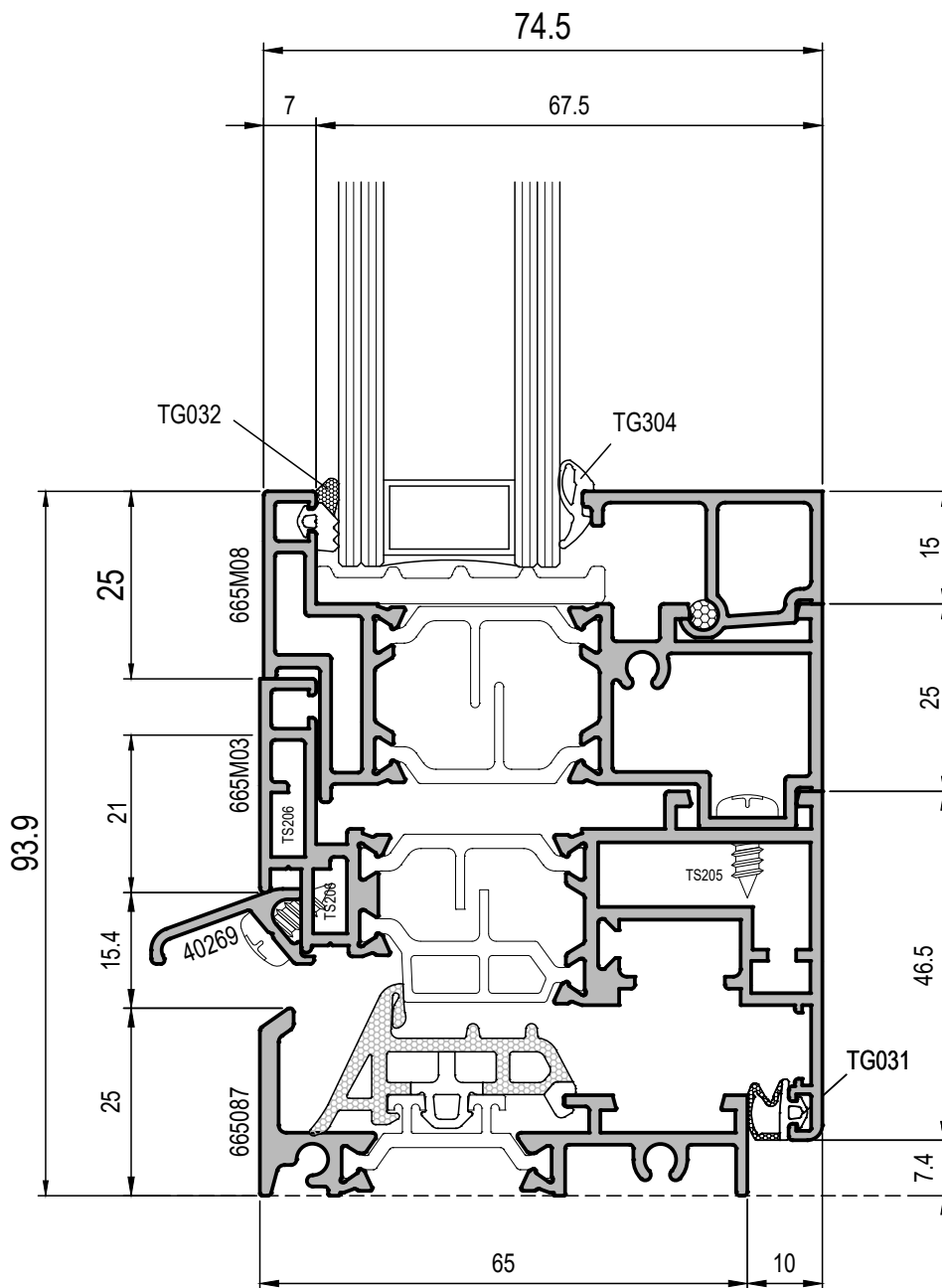

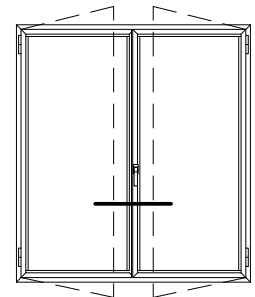
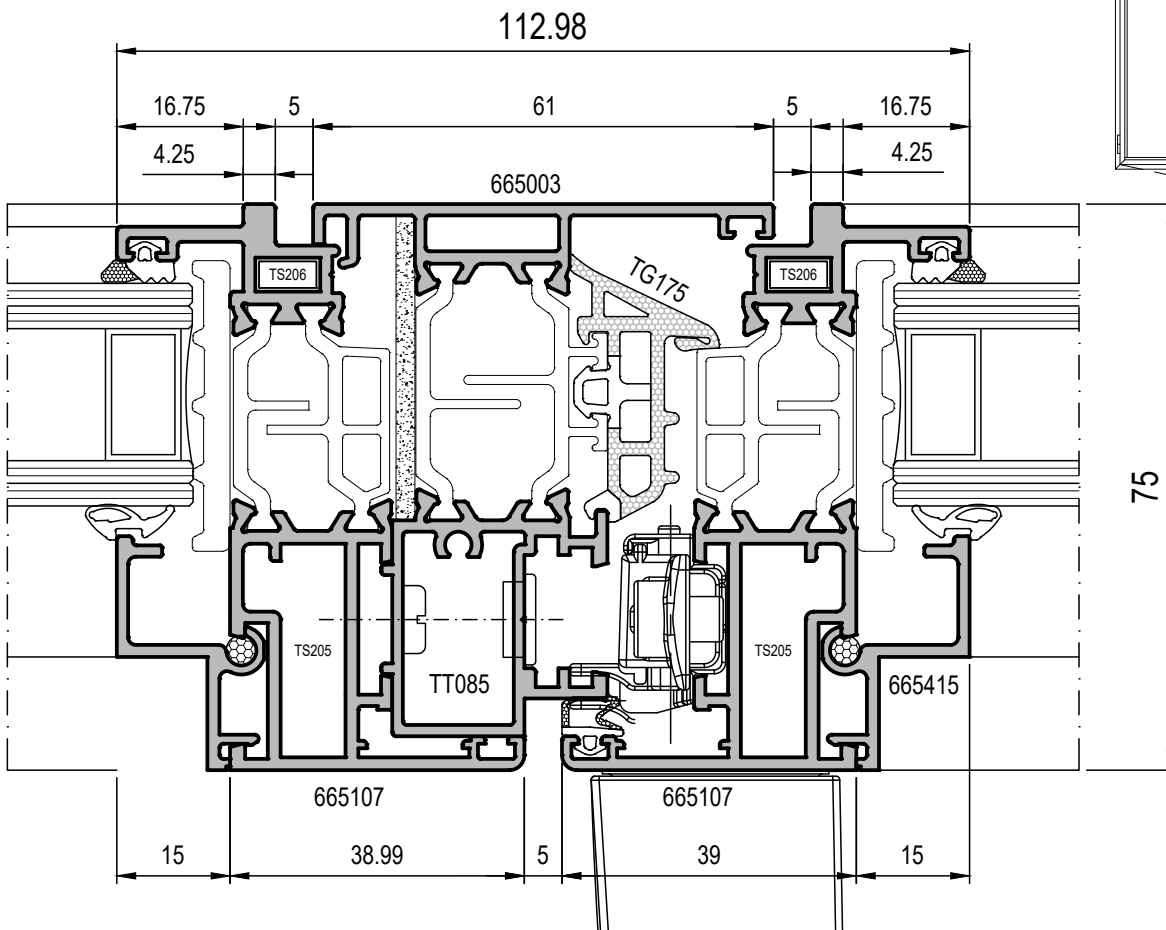
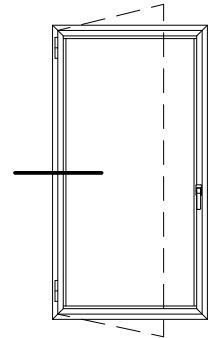
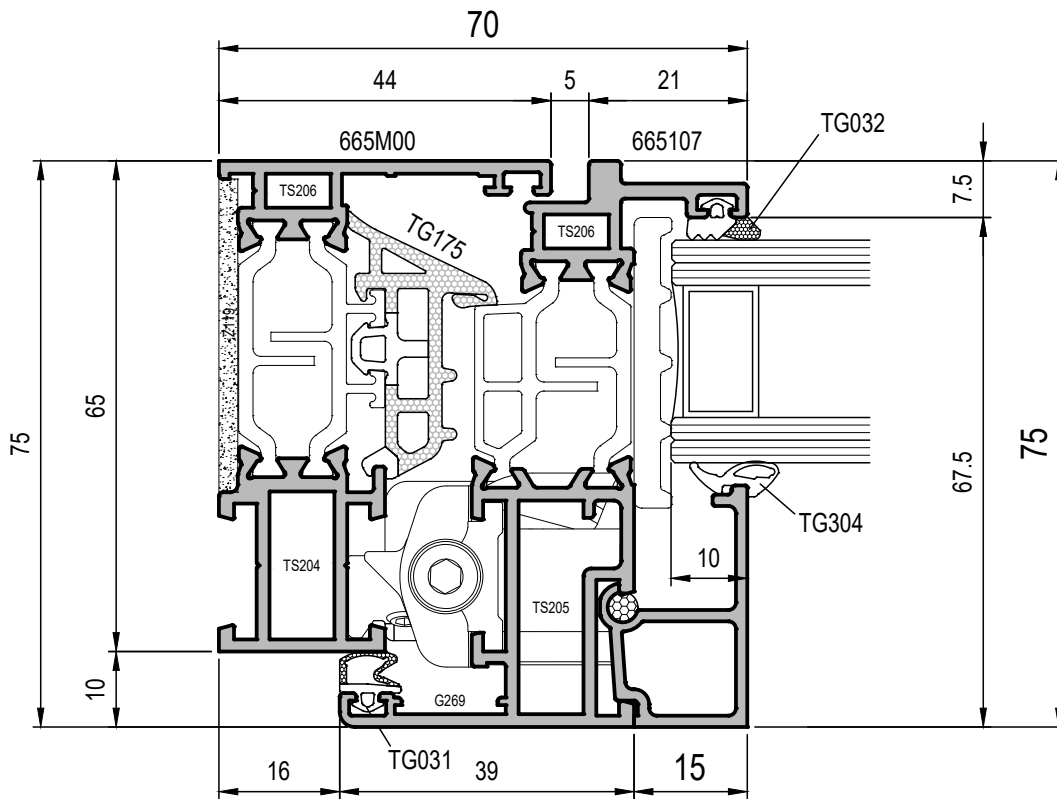
INFERIORE CON ZOCCOLO RIPORTATO
E SOGLIA RIBASSATA PISTA 16 INT.9



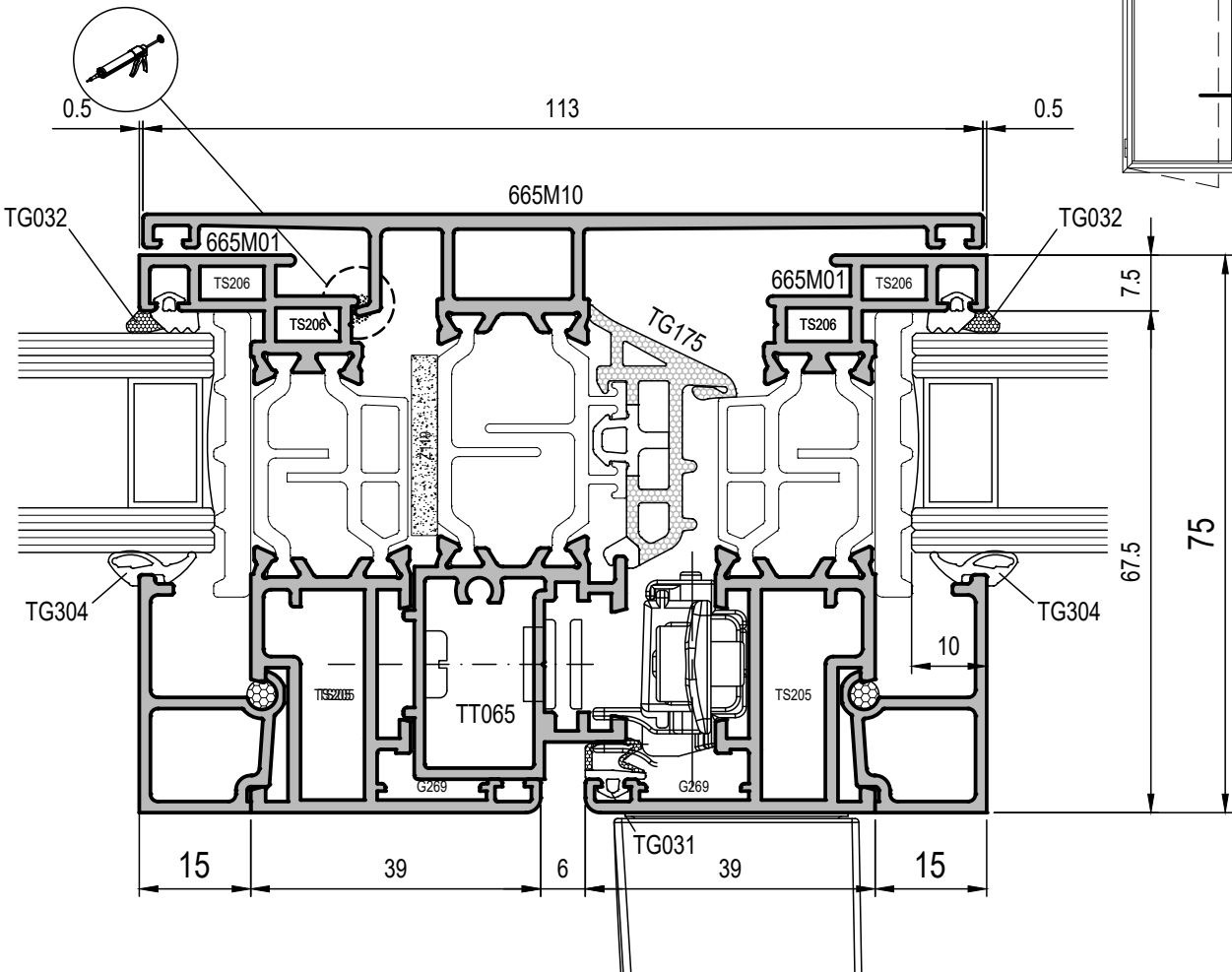
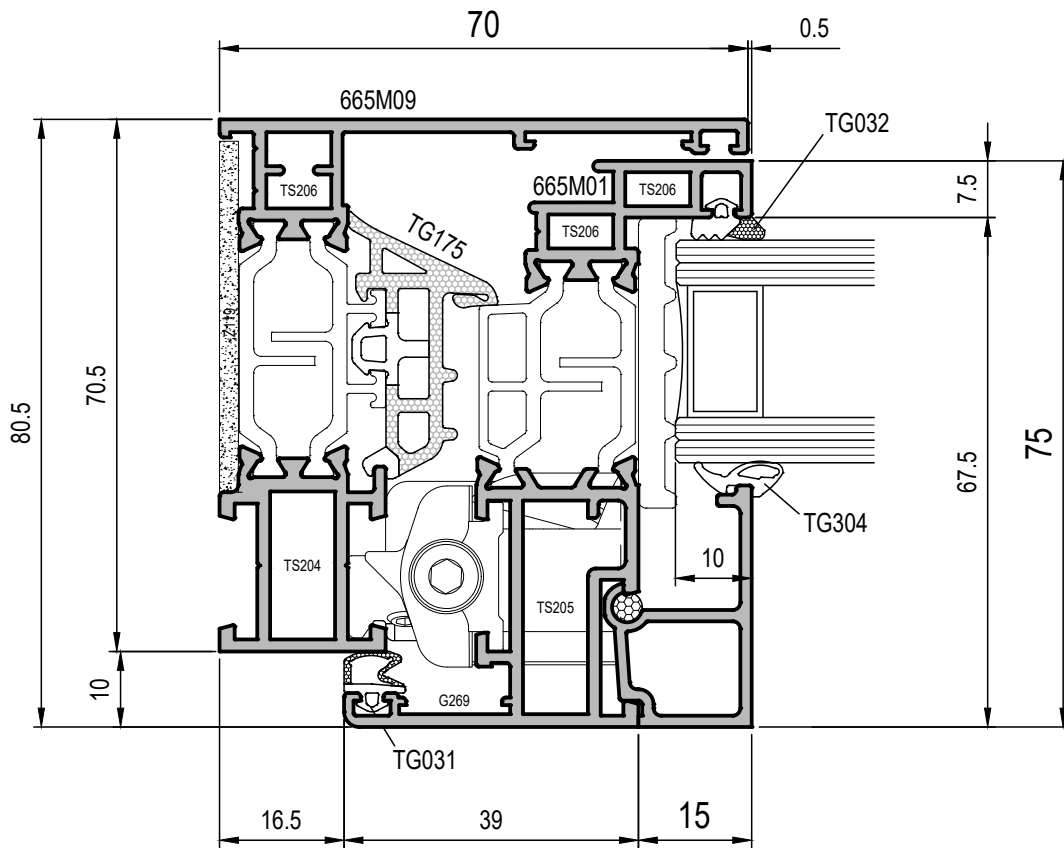





LATERALE E CENTRALE A SCOMPARSA

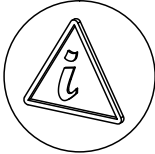
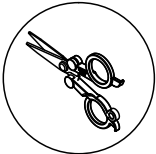
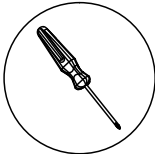
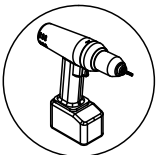
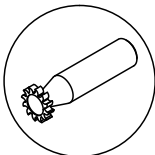
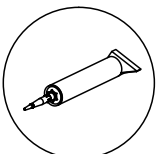

Icône Lavorazioni 
Tipologie Realizzabili 
Schemi Applicazione Accessori 

ICONE LAVORAZIONI

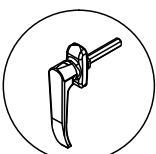
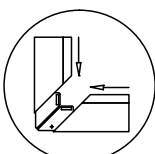
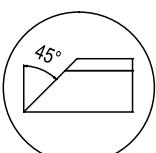
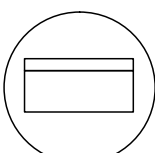
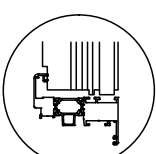

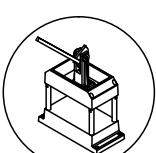
SIMBOLI	DESCRIZIONE	SIMBOLI	DESCRIZIONE
	IMPORTANTE		INFORMAZIONI
	TAGLIARE		AVVITARE / SVITARE
	FORARE		TRANCIARE/ FRESARE
	INCOLLARE		SIGILLARE
	FERRAMENTA		COLLEGARE ANGOLI
	TAGLIARE A 45°		TAGLIARE A 90°
	INTESTARE PROFILATO		PULIRE PERIODICAMENTE CON PANNO
	PUNZONATRICE		

SQUADRETTE DI ASSEMBLAGGIO/ALLINEAMENTO PER PROFILATI CAMERA EUROPEA

SQUADRETTA DI ASSEMBLAGGIO INTERNA:
DISPONIBILE, SIA PER I TELAI CHE PER LE ANTE, NELLA VERSIONE A SPINO-CIANFRINARE (TS204 - TS205).

SQUADRETTA DI ASSEMBLAGGIO INTERNA:
DISPONIBILE, SIA PER I TELAI CHE PER LE ANTE, NELLA VERSIONE A CIANFRINARE (TS206)

SQUADRETTA DI ALLINEAMENTO:
DISPONIBILE, PER I TELAI CON CAMME DI BLOCCAGGIO (G501N).
PER LE ANTE NELLA CAMERA PIÙ ESTERNA INSERIRE LA TS206
PER L'ALETTA INTERNA DELLE ANTE E I TELAI E' DISPONIBILE LA SQUADRETTA IN ACCIAIO G269.

N.B. NELLE SEDI PORTAGUARNIZIONI E' CONSIGLIABILE INSERIRE SEMPRE LA SQUADRETTA DI ALLINEAMENTO IN ACCIAIO G112.



N.B. : INCOLLARE ACCURATAMENTE LE SQUADRETTE

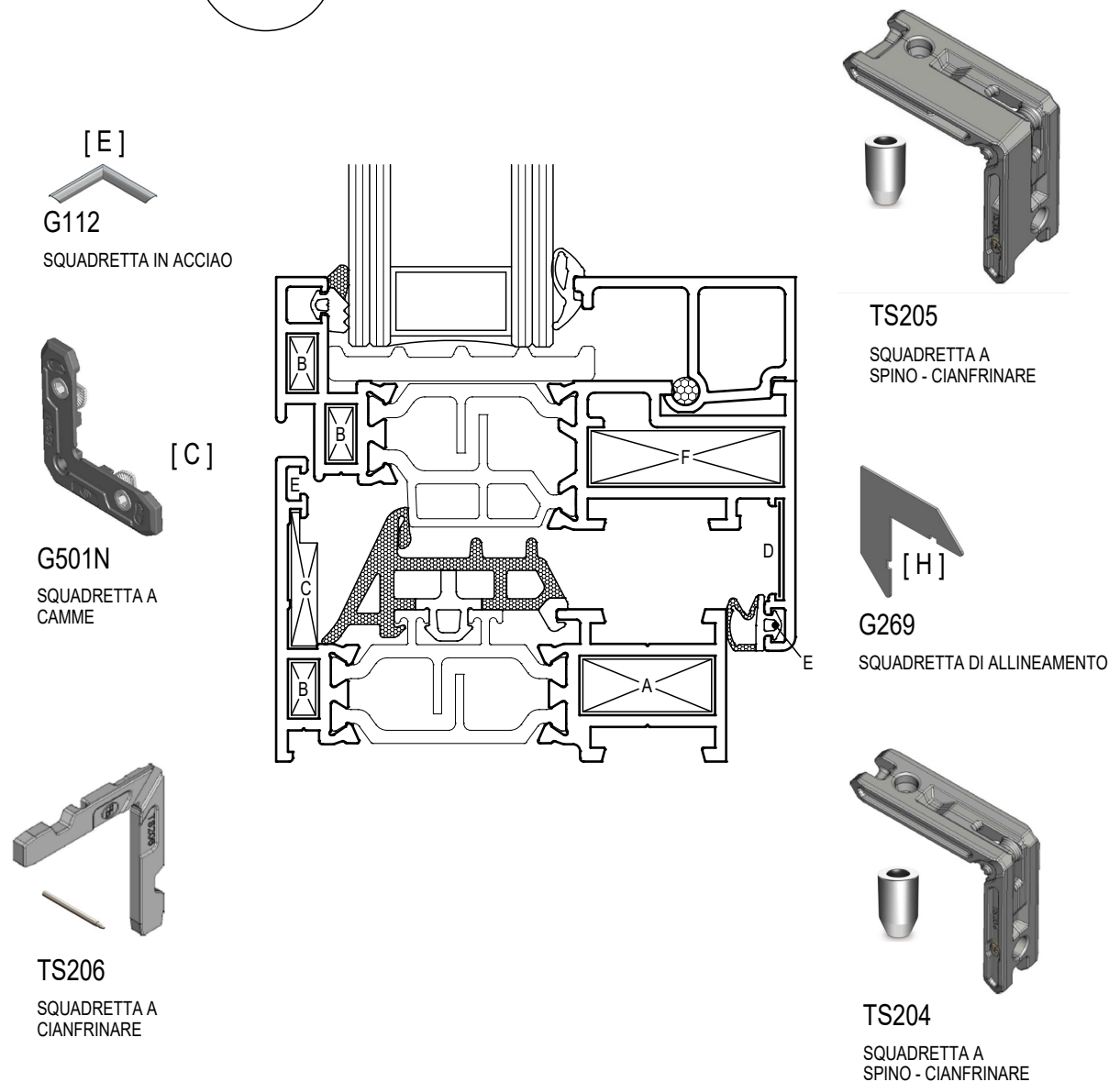

SQUADRETTE DI ASSEMBLAGGIO/ALLINEAMENTO PER PROFILATI PISTA 16



SQUADRETTA DI ASSEMBLAGGIO INTERNA:

DISPONIBILE, SIA PER I TELAI CHE PER LE ANTE, NELLA VERSIONE A SPINO-CIANFRINARE (TS204 - TS205).

SQUADRETTA DI ASSEMBLAGGIO INTERNA:

DISPONIBILE, SIA PER I TELAI CHE PER LE ANTE, NELLA VERSIONE A CIANFRINARE (TS206)

SQUADRETTA DI ALLINEAMENTO:

DISPONIBILE, PER I TELAI CON CAMME DI BLOCCAGGIO (G501N).

PER LE ANTE NELLA CAMERA PIÙ ESTERNA INSERIRE LA TS206

PER L'ALETTA INTERNA DEI TELAI E' DISPONIBILE LA SQUADRETTA IN ACCIAIO G269.

N.B. NELLE SEDI PORTAGUARNIZIONI E' CONSIGLIABILE INSERIRE SEMPRE LA SQUADRETTA DI ALLINEAMENTO IN ACCIAIO G112.

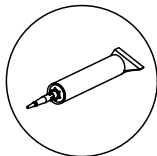

N.B. : INCOLLARE ACCURATAMENTE LE SQUADRETTE

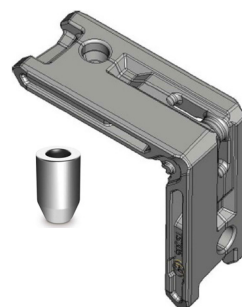
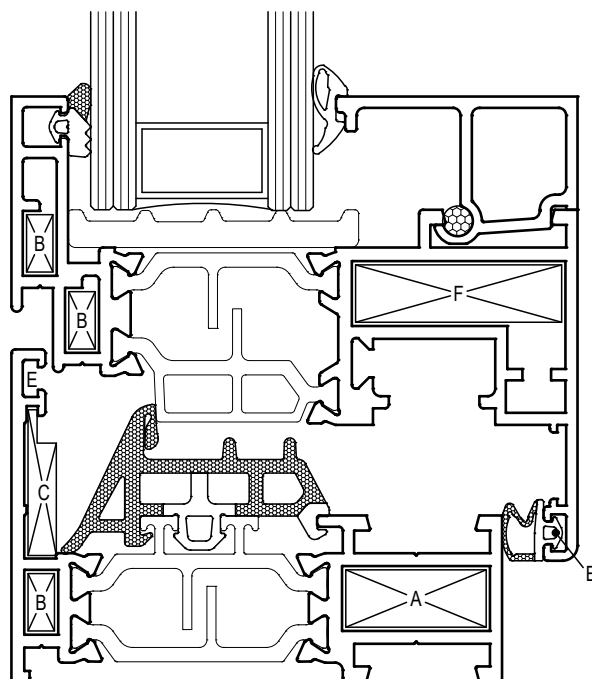
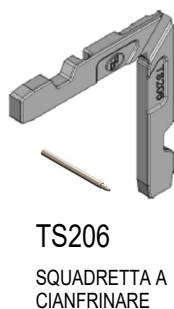

TS205
SQUADRETTA A
SPINO - CIANFRINARE



TS204
SQUADRETTA A
SPINO - CIANFRINARE

INDICAZIONI PER IL TAGLIO DEI PROFILATI

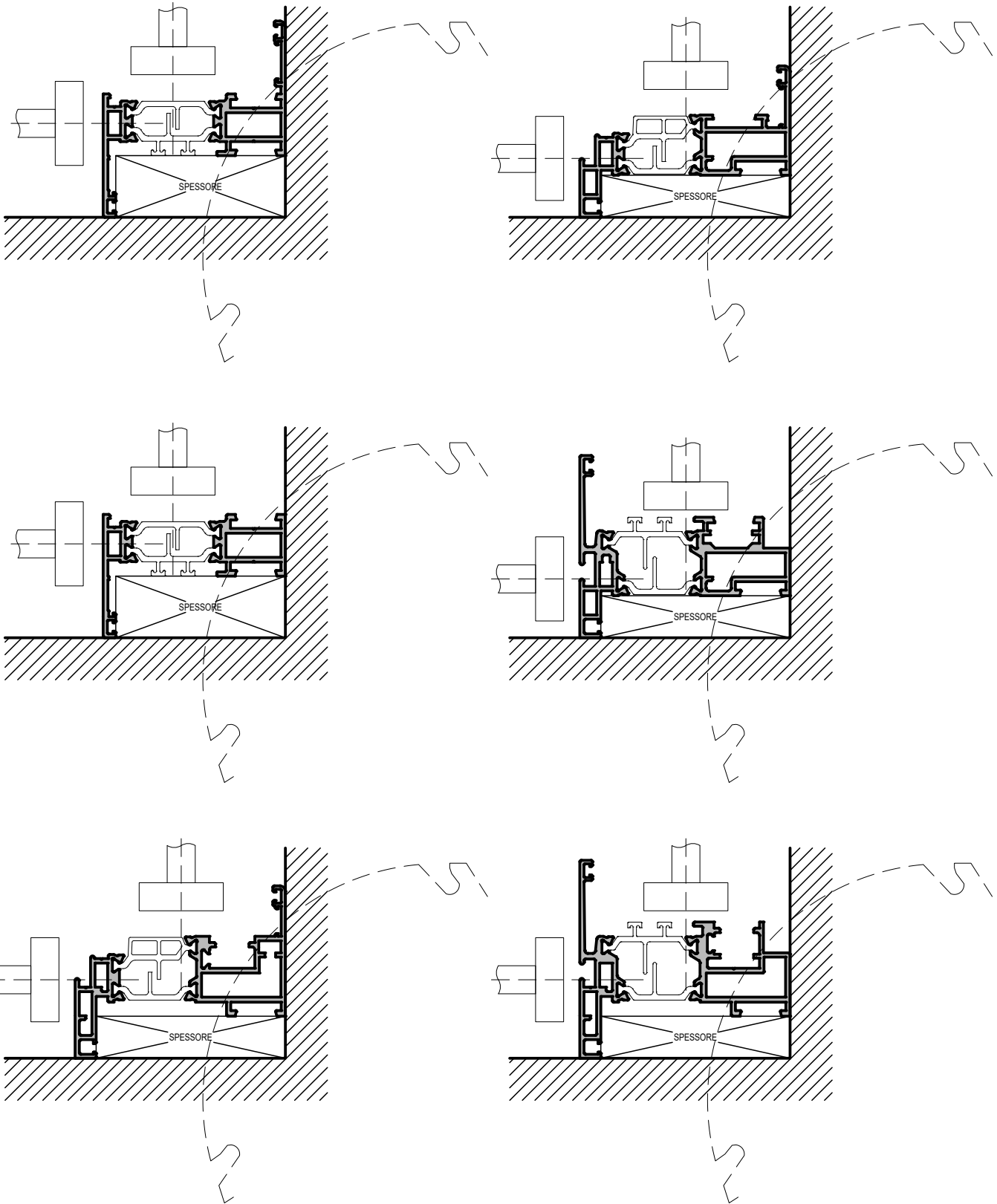

PRECAUZIONI PER LA REALIZZAZIONE DI UN BUON ANGOLO :

- CURARE IL POSIZIONAMENTO DEI PROFILATI ASSICURANDOSI CHE LE SUPERFICI DI APPOGGIO SIANO PULITE.
- UTILIZZARE DEI SUPPORTI PER IL CORRETTO POSIZIONAMENTO DEI PROFILATI SUI PIANI DI LAVORO.
- ASSICURARSI DI APPLICARE LA GIUSTA PRESSIONE AI PISTONI DI SERRAGGIO ACCERTANDOSI CHE IL PROFILO NON SI SPOSTI O ROUTI.



Lavorazioni 

TA089 REGOLO FISSAGGIO TELAIO A MURO

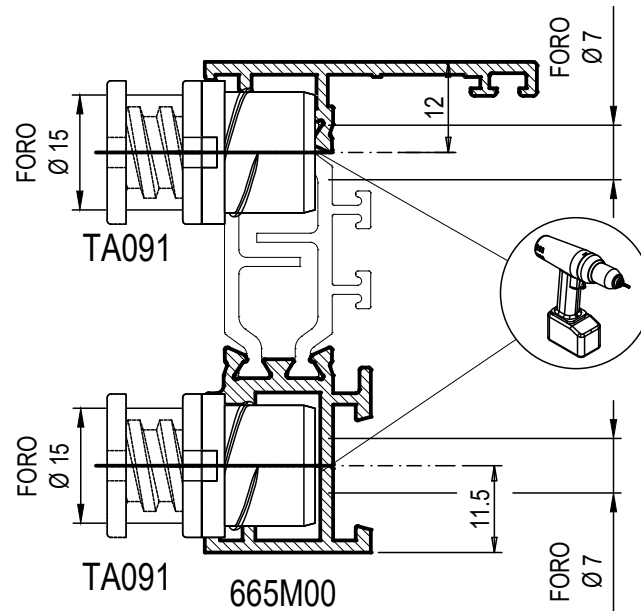

TA089 REGOLO FISSAGGIO CENTRALE TELAIO A MURO

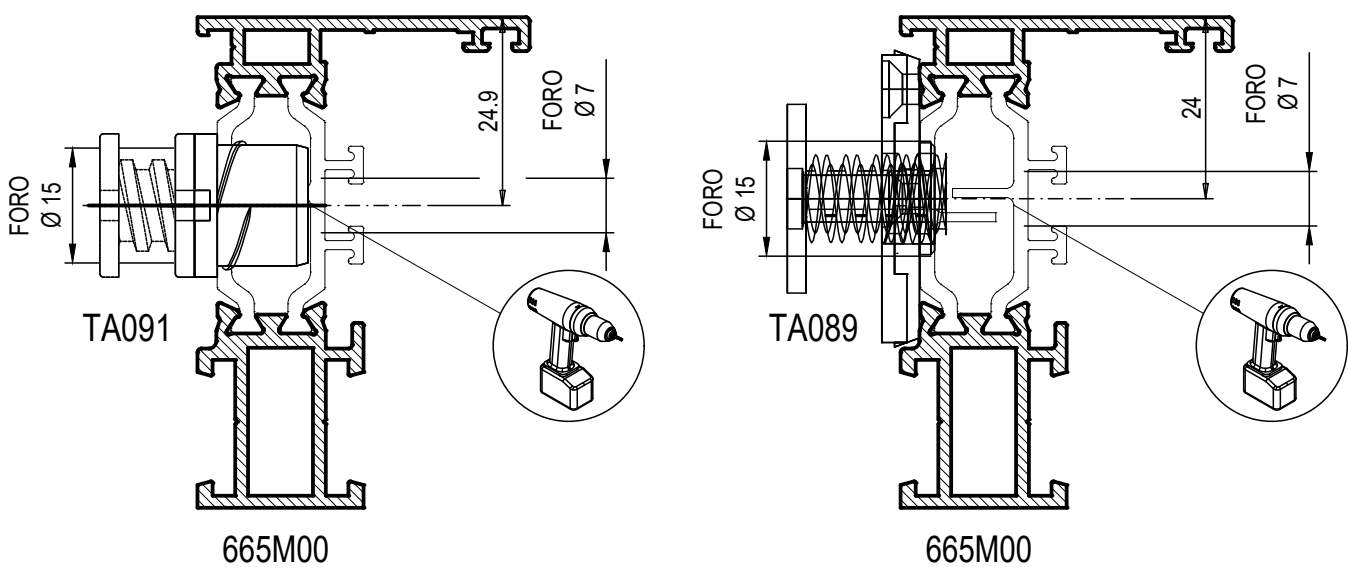

LAVORAZIONE PER SQUADRETTE TELAIO

DA ESEGUIRE CON TRACIANTE TI015 O DIMA GA119

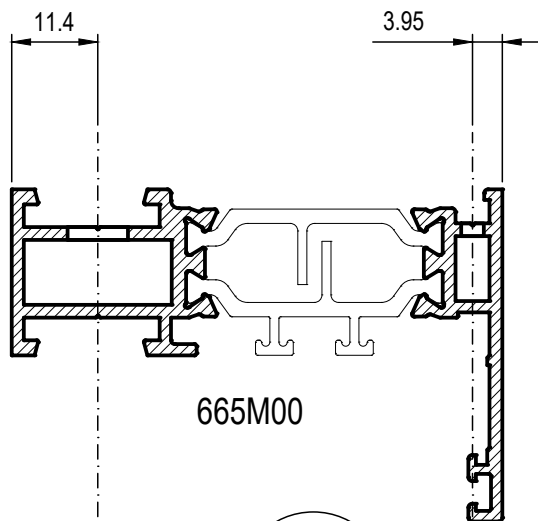

PER IL SERRAGGIO UTILIZZARE
SPINA S810

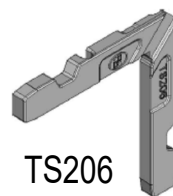

PER IL SERRAGGIO UTILIZZARE
SPINA G266 O SPINA S3001

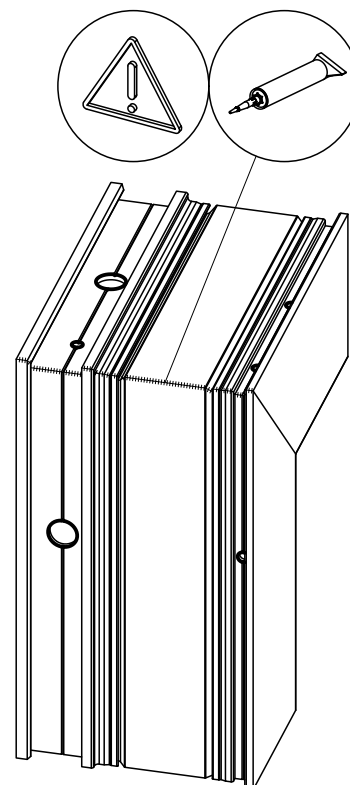
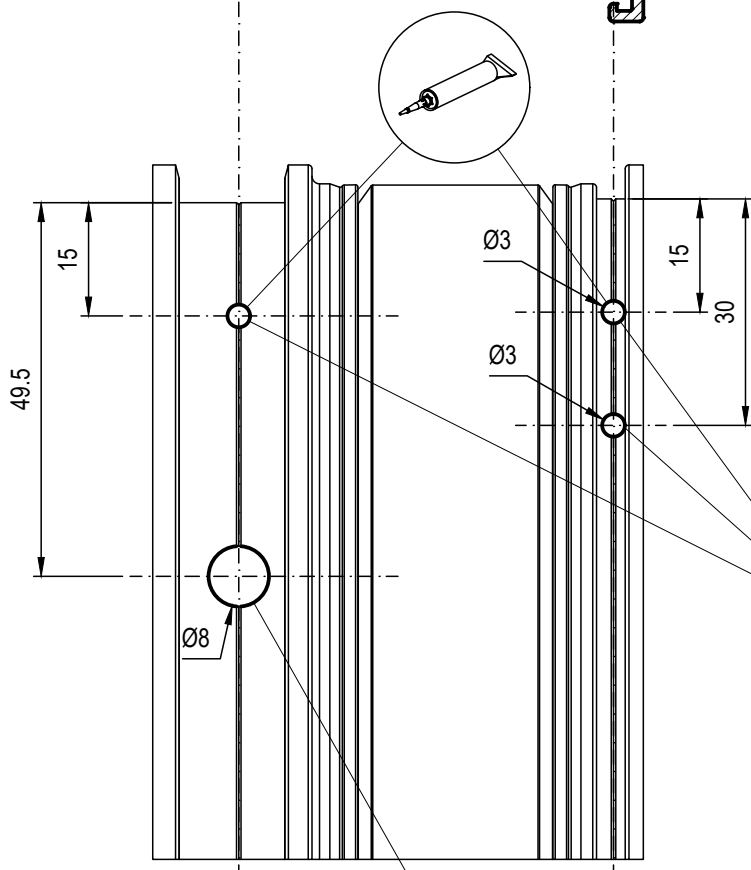

VALIDA ANCHE PER ANTA 665M09 - 665M11

LAVORAZIONE PER SQUADRETTE ANTA Z CAMERA EUROPEA

DA ESEGUIRE CON TRACIANTE TI015 O DIMA GA118



PER IL SERRAGGIO UTILIZZARE
SPINA S810

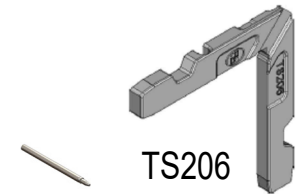

PER IL SERRAGGIO UTILIZZARE
SPINA G266 O SPINA S3001

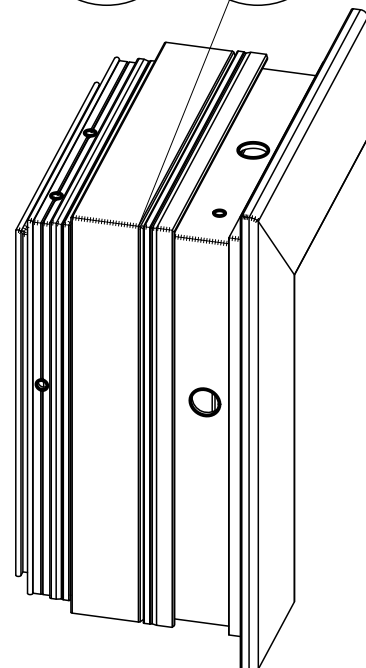
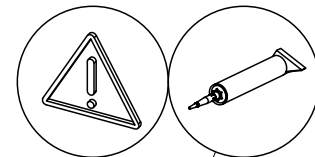
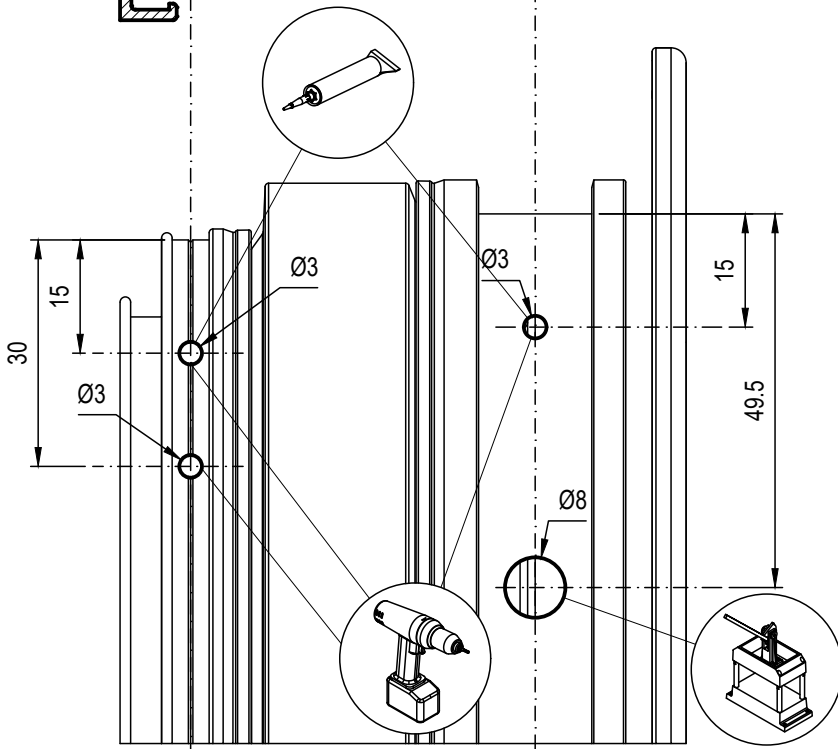
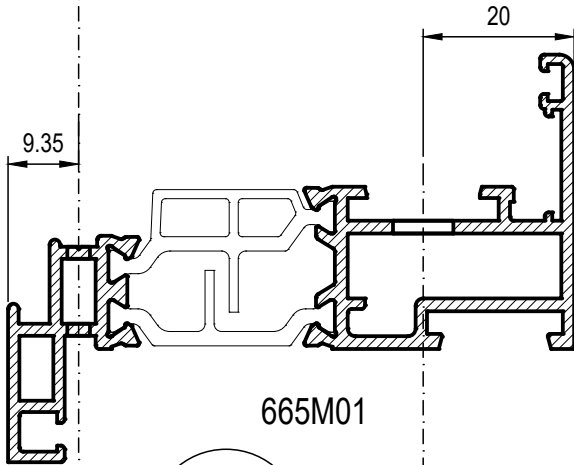

VALIDA ANCHE PER ANTA 665M07



LAVORAZIONE PER SQUADRETTE ANTA T CAMERA EUROPEA

DA ESEGUIRE CON TRACIANTE TI015 O DIMA GA118

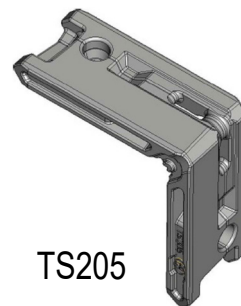
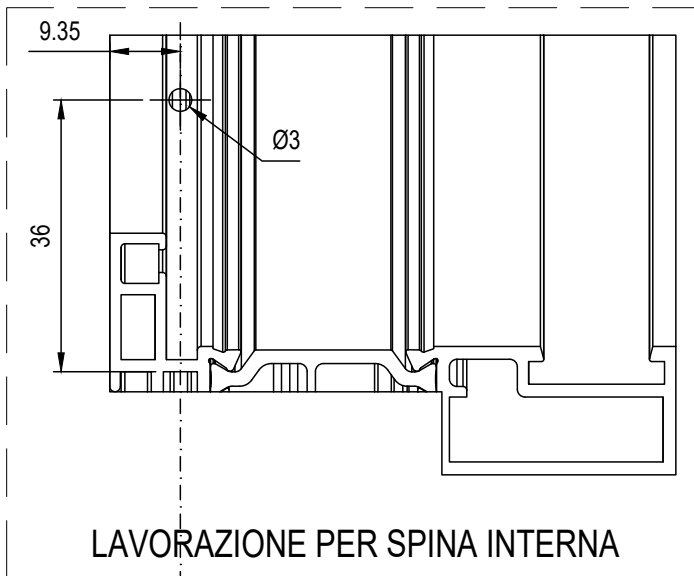

TS205



PER IL SERRAGGIO UTILIZZARE
SPINA S810

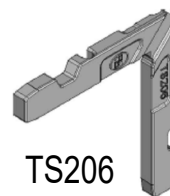

TS206

PER IL SERRAGGIO UTILIZZARE
SPINA G266 O SPINA S3001

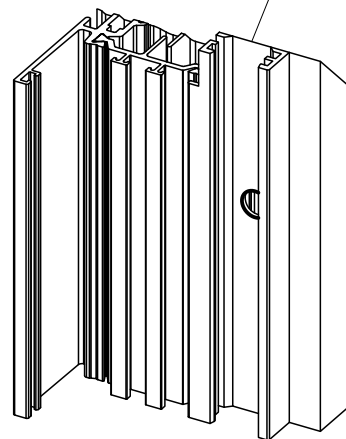
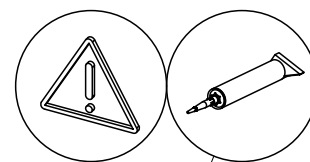
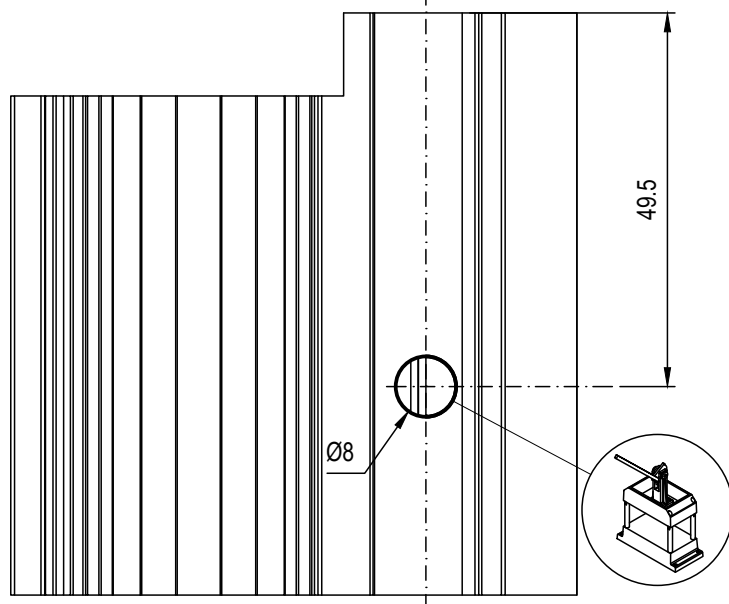
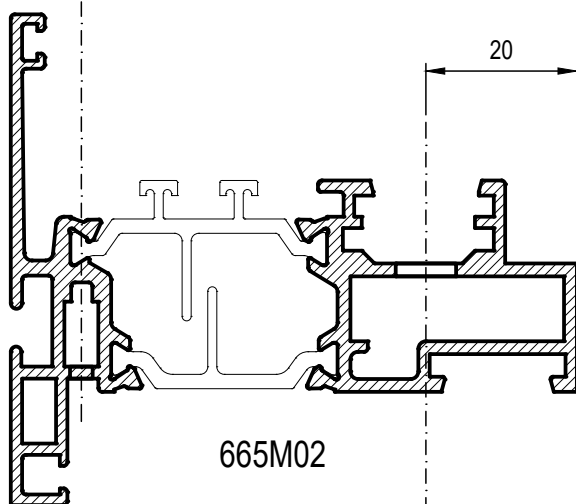

LAVORAZIONE PER SQUADRETTE ANTA Z PISTA 16 INT.9

DA ESEGUIRE CON TRACIANTE TI015 O DIMA GA120

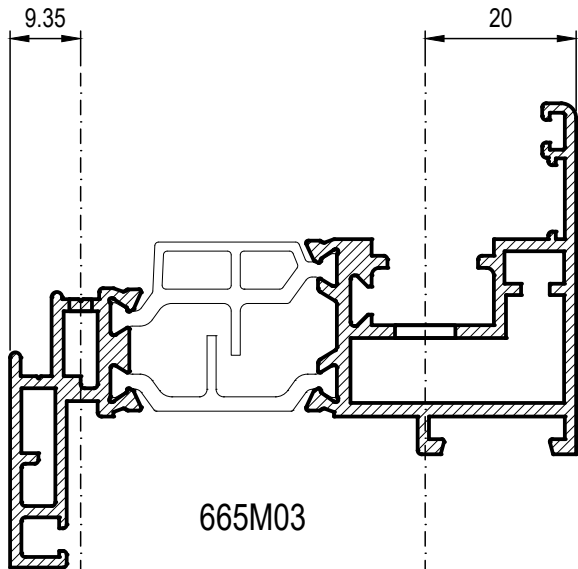

665M03



TS205



PER IL SERRAGGIO UTILIZZARE
SPINA S810

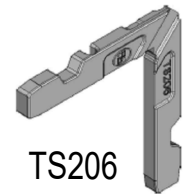

TS206

PER IL SERRAGGIO UTILIZZARE
SPINA G266 O SPINA S3001

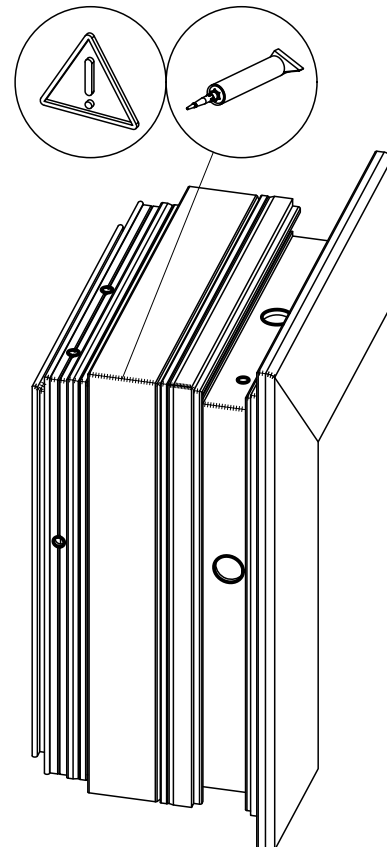
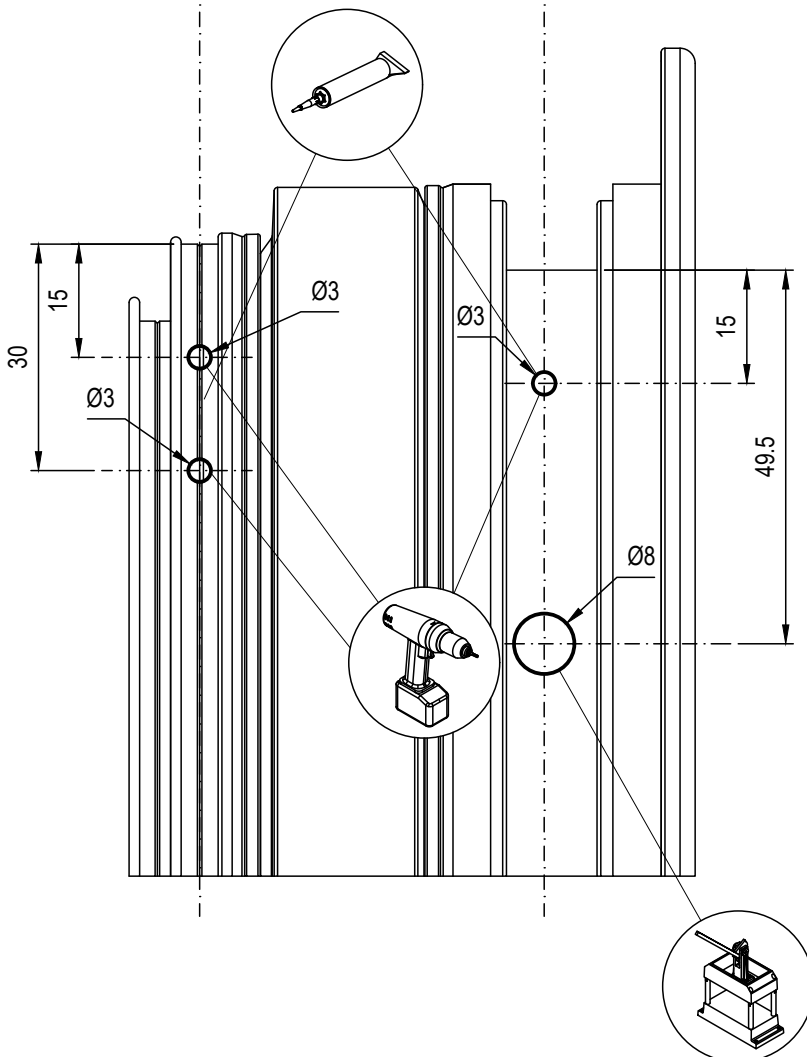

LAVORAZIONE PER SQUADRETTE ANTA T PISTA 16 INT.9

DA ESEGUIRE CON TRACIANTE TI015 O DIMA GA120

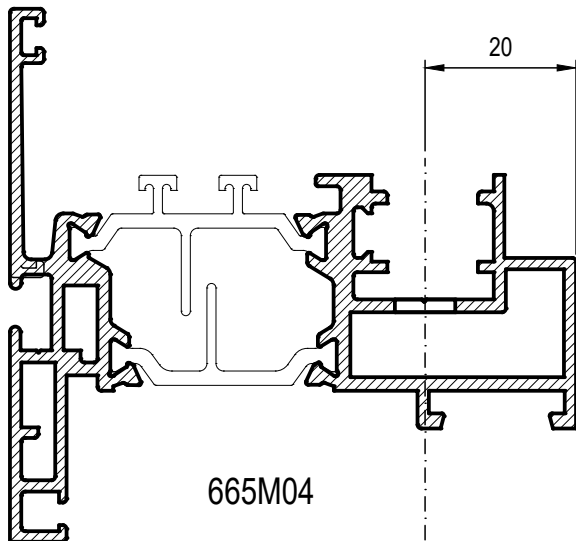

PER IL SERRAGGIO UTILIZZARE
SPINA S810



PER IL SERRAGGIO UTILIZZARE
SPINA G266 O SPINA S3001

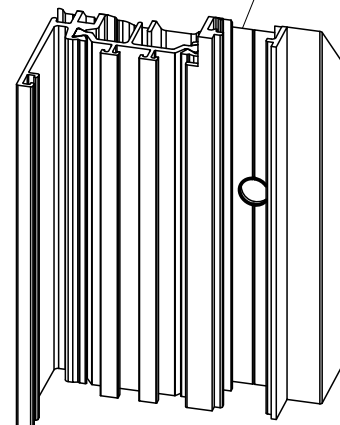
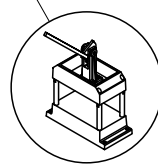
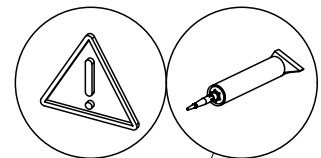
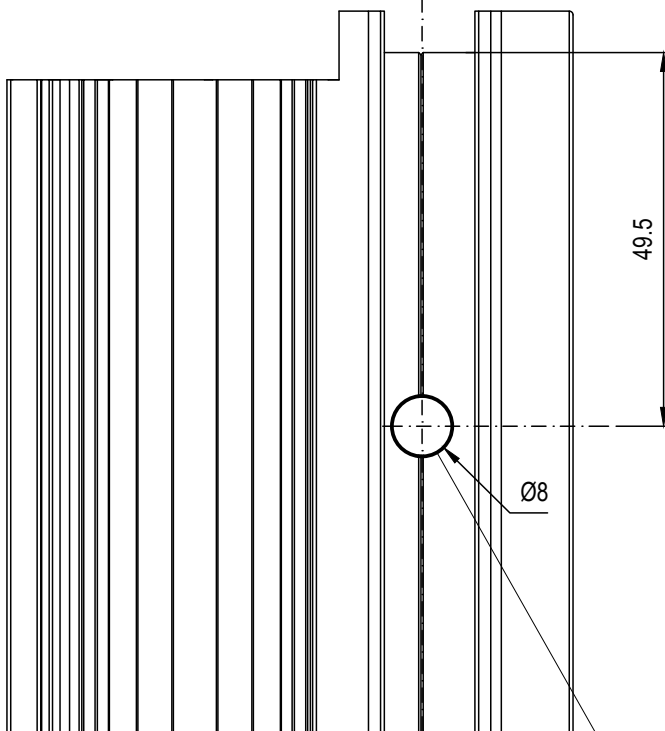

LAVORAZIONE PER INCONTRO CENTRALE SOLUZIONE T-Z CAMERA EUROPEA DA ESEGUIRE CON GRUPPO FRESA GFDTZ1

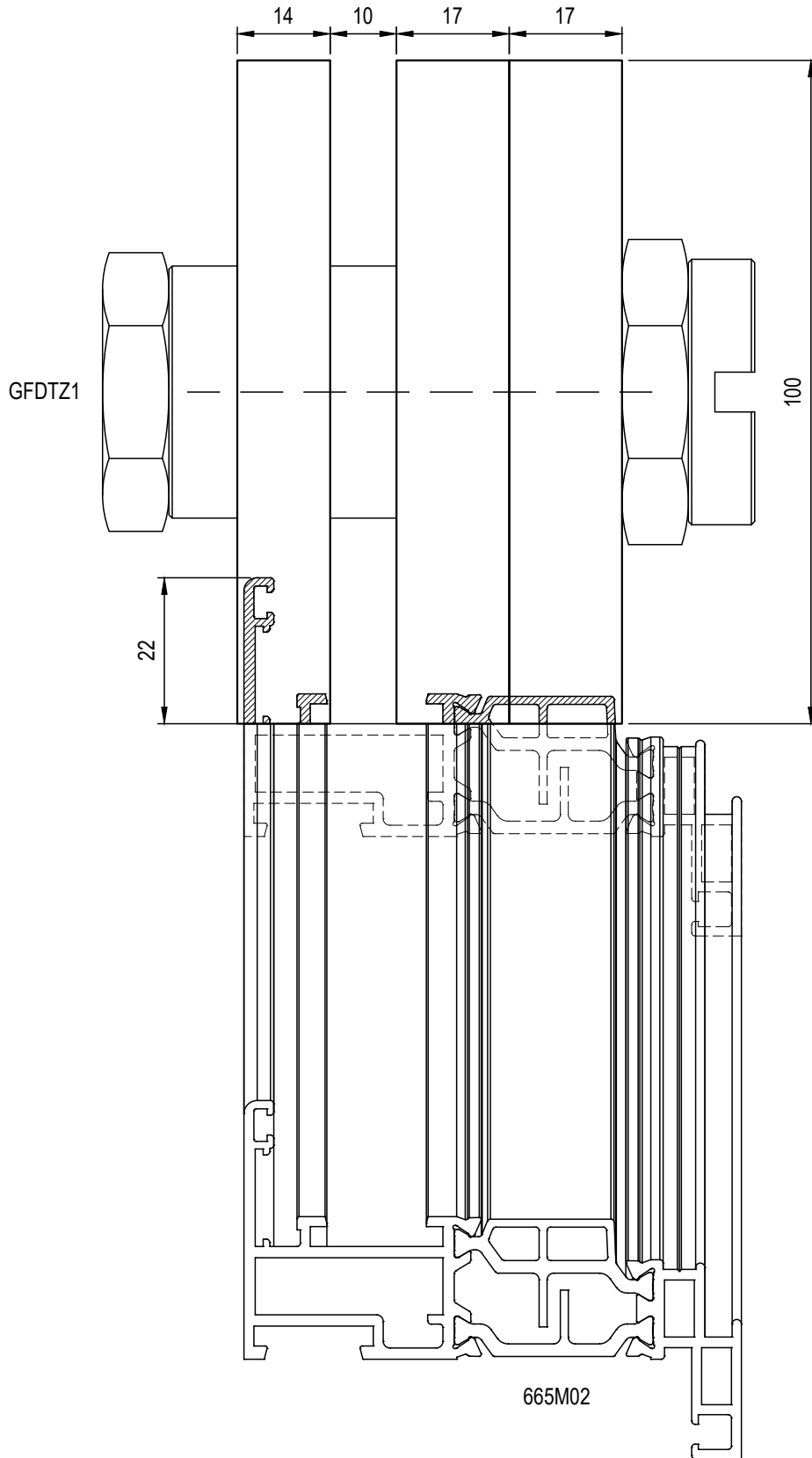

LAVORAZIONE PER INCONTRO CENTRALE
SOLUZIONE T-Z CAMERA EUROPEA
DA ESEGUIRE CON GRUPPO FRESA GFDTZ3

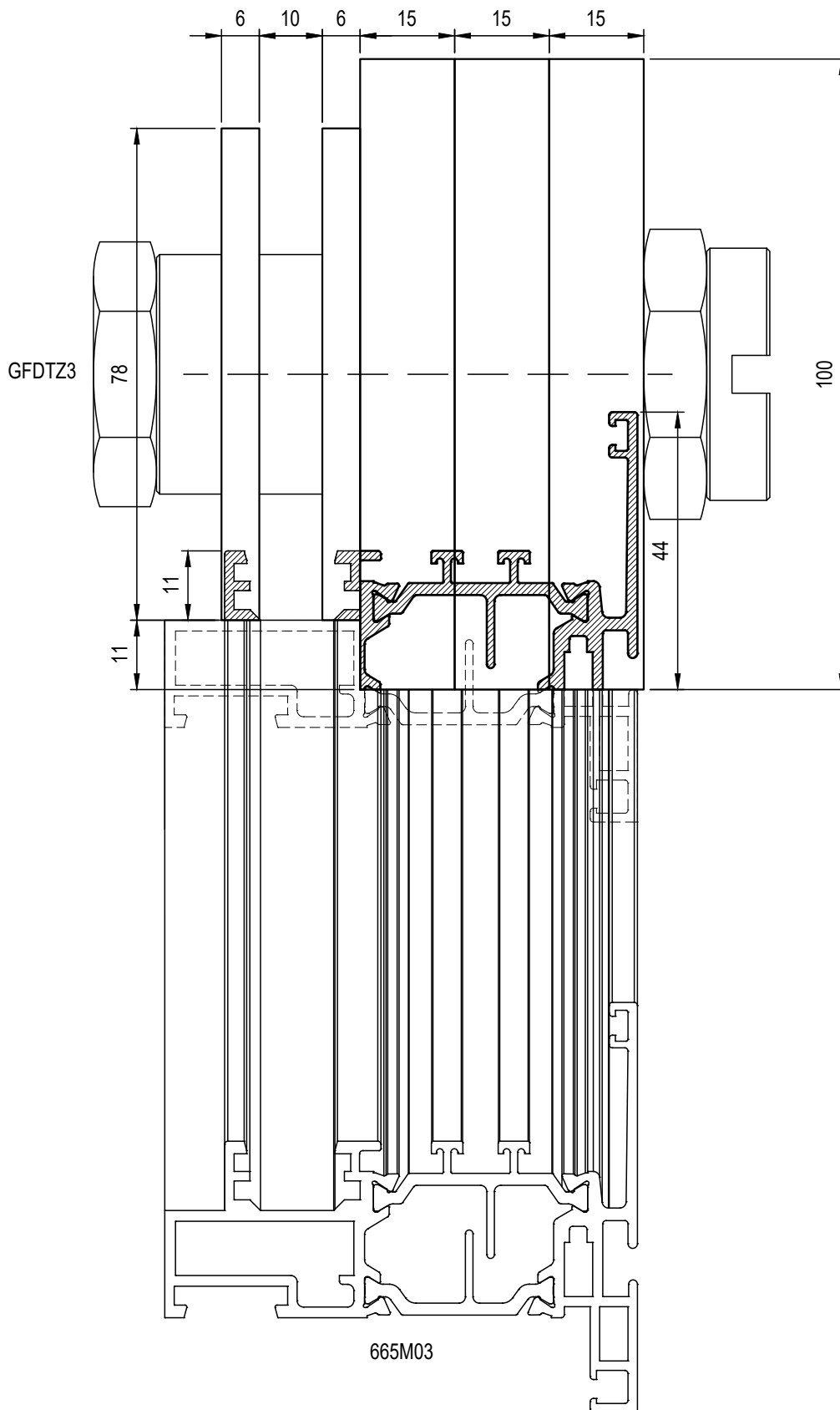

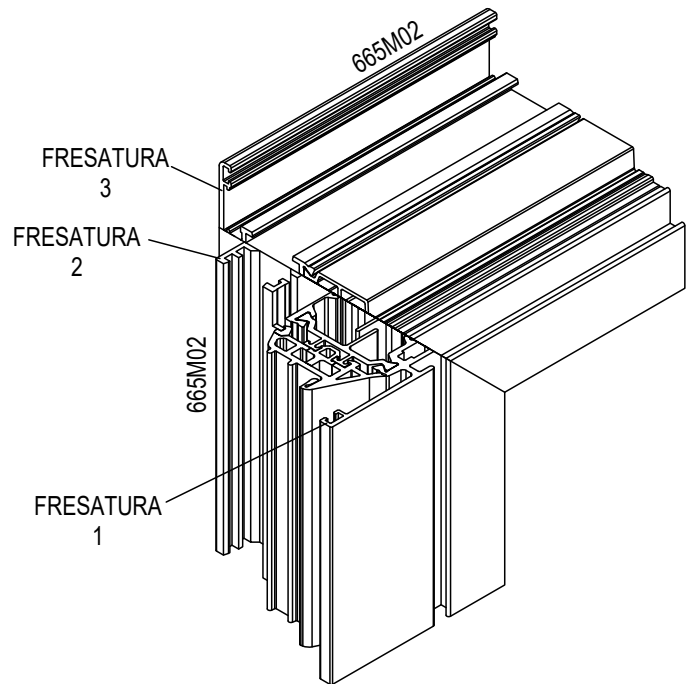
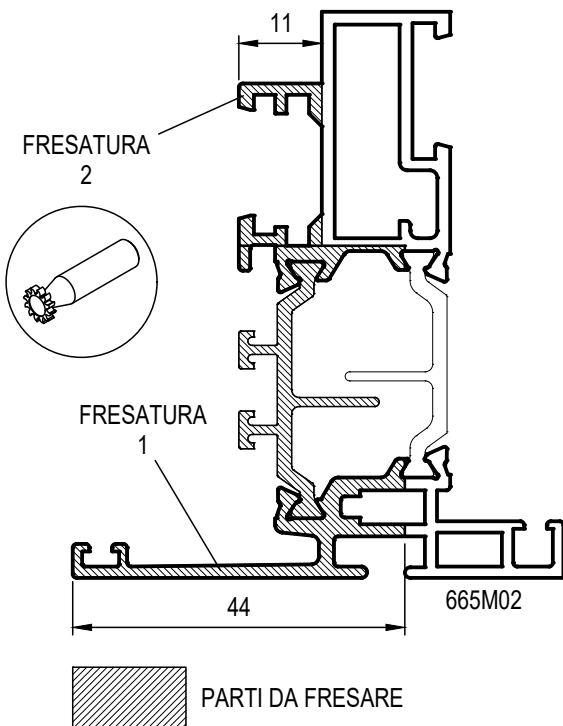
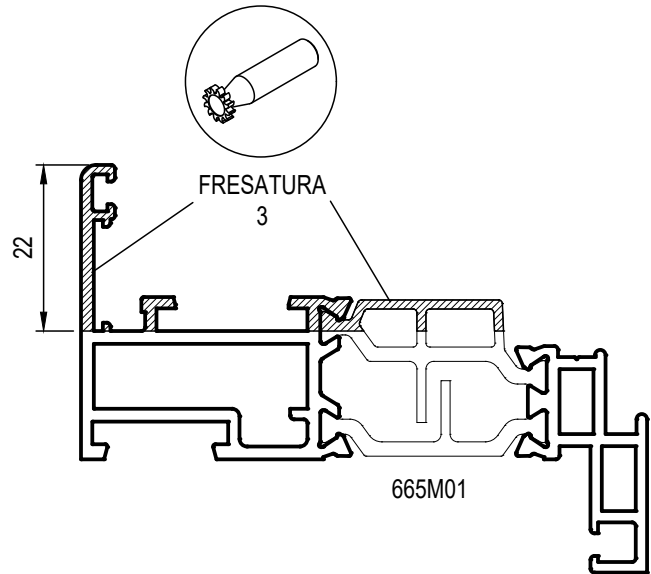
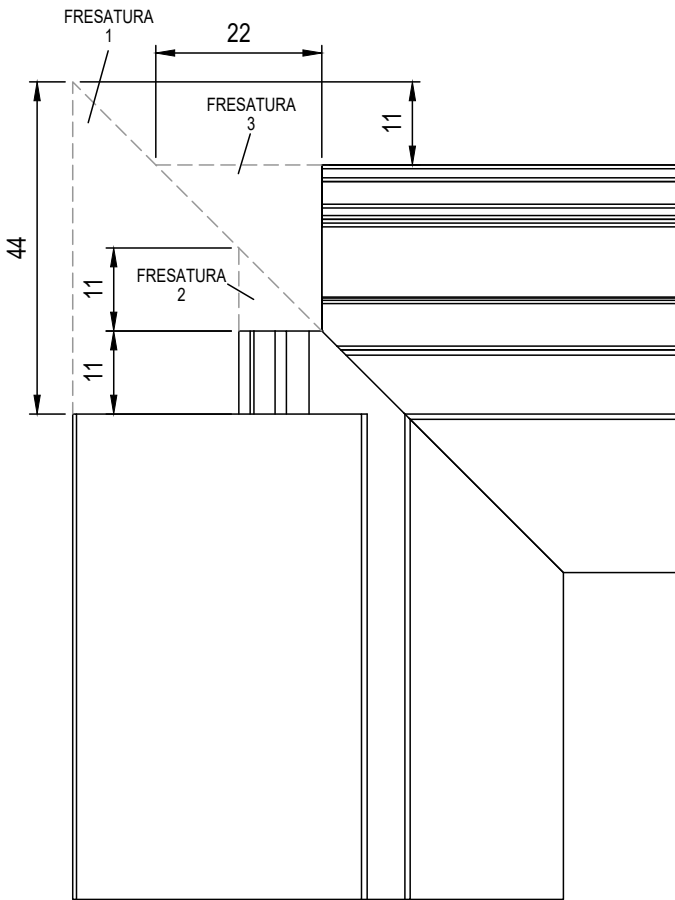

LAVORAZIONE PER INCONTRO CENTRALE T-Z CAMERA EUROPEA

ELENCO FRESATURE

- FRESATURA 1 ALETTA ESTERNA PROFILATO A "T" 665M02,
BARRETTA ISOLANTE,
DENTINI ESTERNI GOLA CAMERA EUROPEA
SU PROFILATO "T" 665M02
- FRESATURA 2 DENTINI INTERNI GOLA CAMERA EUROPEA
SU PROFILATO "T" 665M02,
- FRESATURA 3 ALETTA DI BATTUTA PROFILO "Z" 665M01,
DENTINI CAMERA EUROPEA PROFILATO "Z",
BARRETTA ISOLANTE PROFILATO "Z"

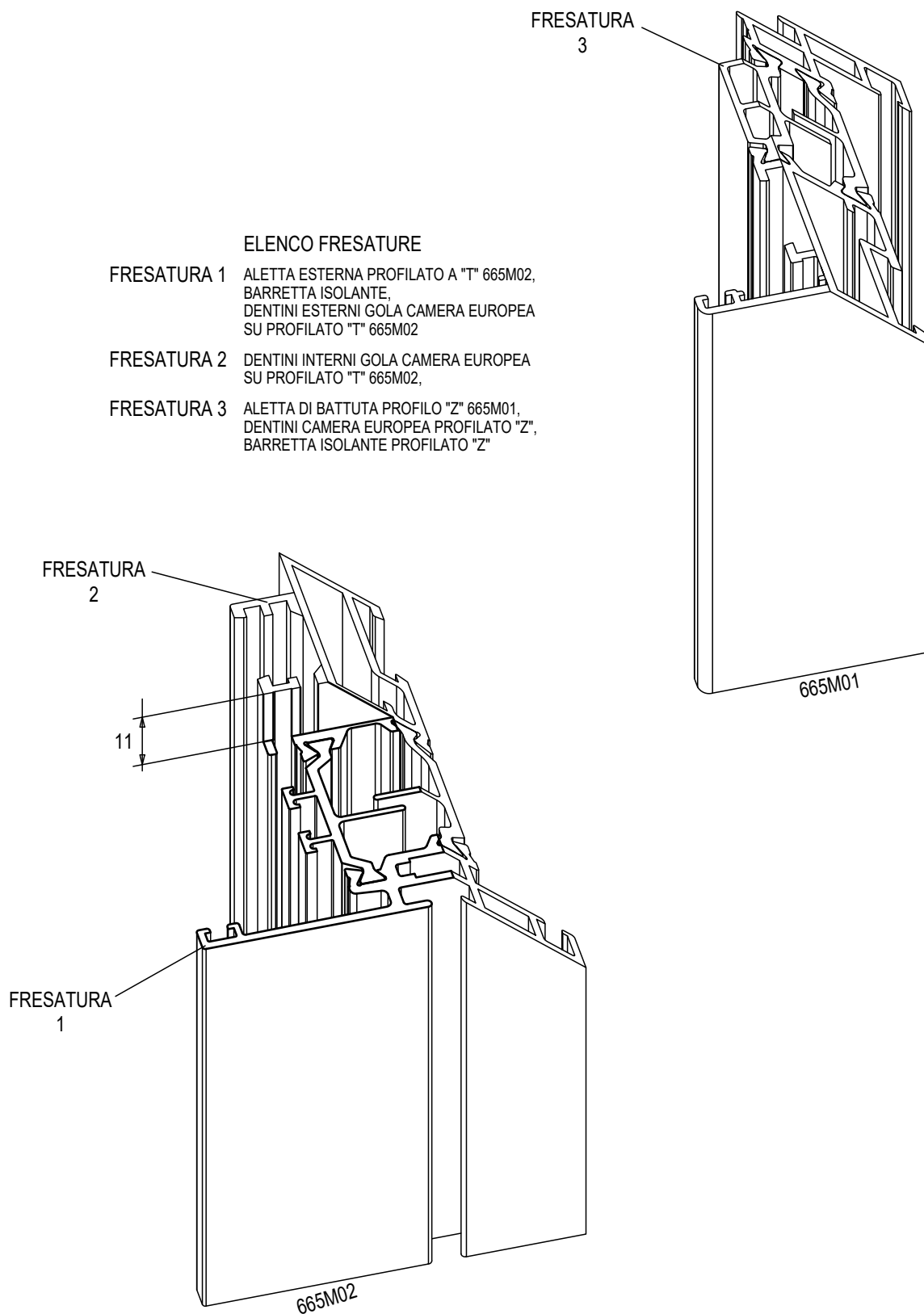

ASSEMBLAGGIO INCONTRO CENTRALE T-Z CAMERA EUROPEA

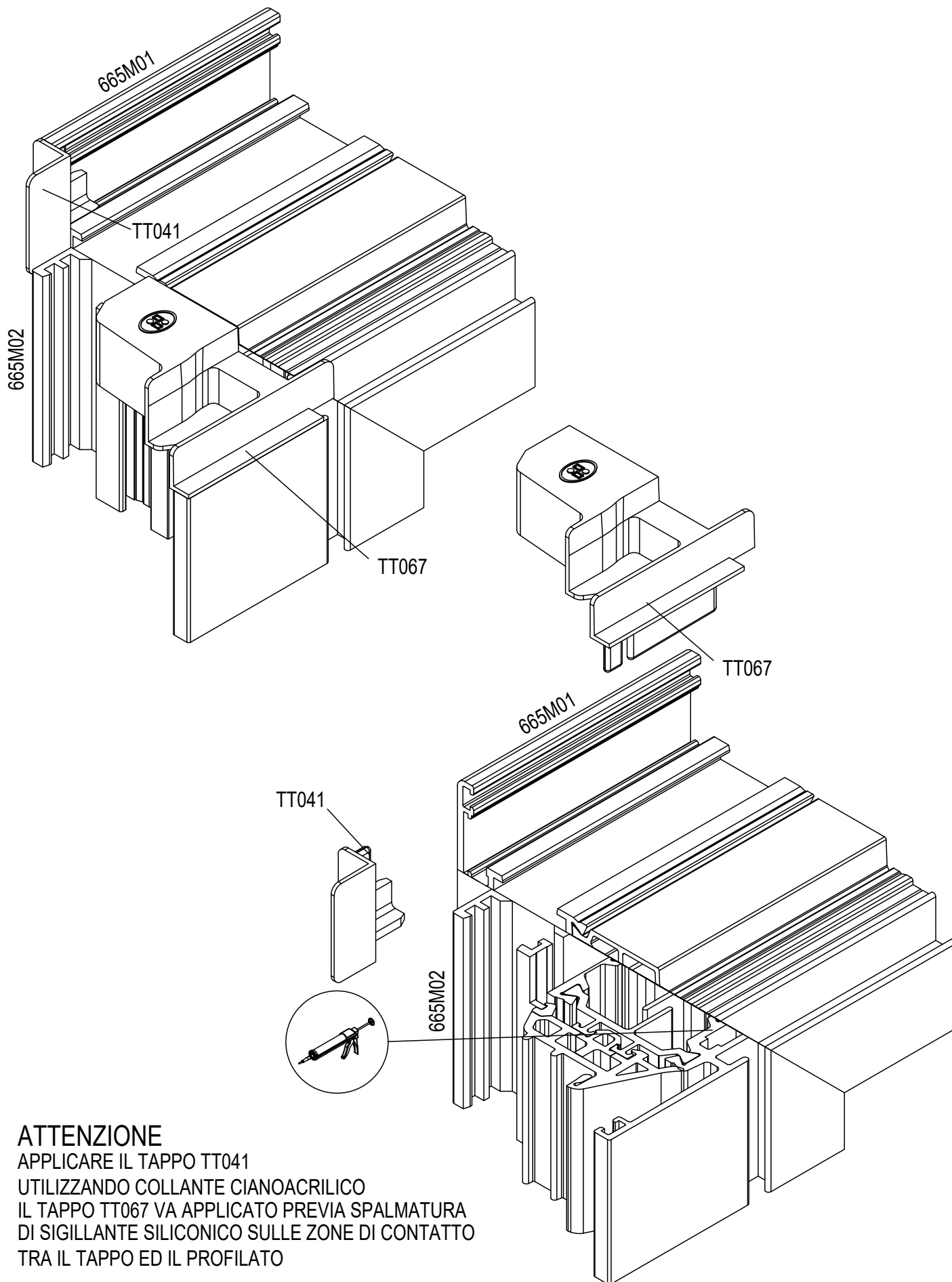

ATTENZIONE

APPLICARE IL TAPPO TT041
UTILIZZANDO COLLANTE CIANOACRILICO
IL TAPPO TT067 VA APPLICATO PREVIA SPALMATURA
DI SIGILLANTE SILICONICO SULLE ZONE DI CONTATTO
TRA IL TAPPO ED IL PROFILATO

LAVORAZIONE PER INCONTRO CENTRALE
SOLUZIONE T-Z PISTA 16
DA ESEGUIRE CON GRUPPO FRESA GFDTZ1

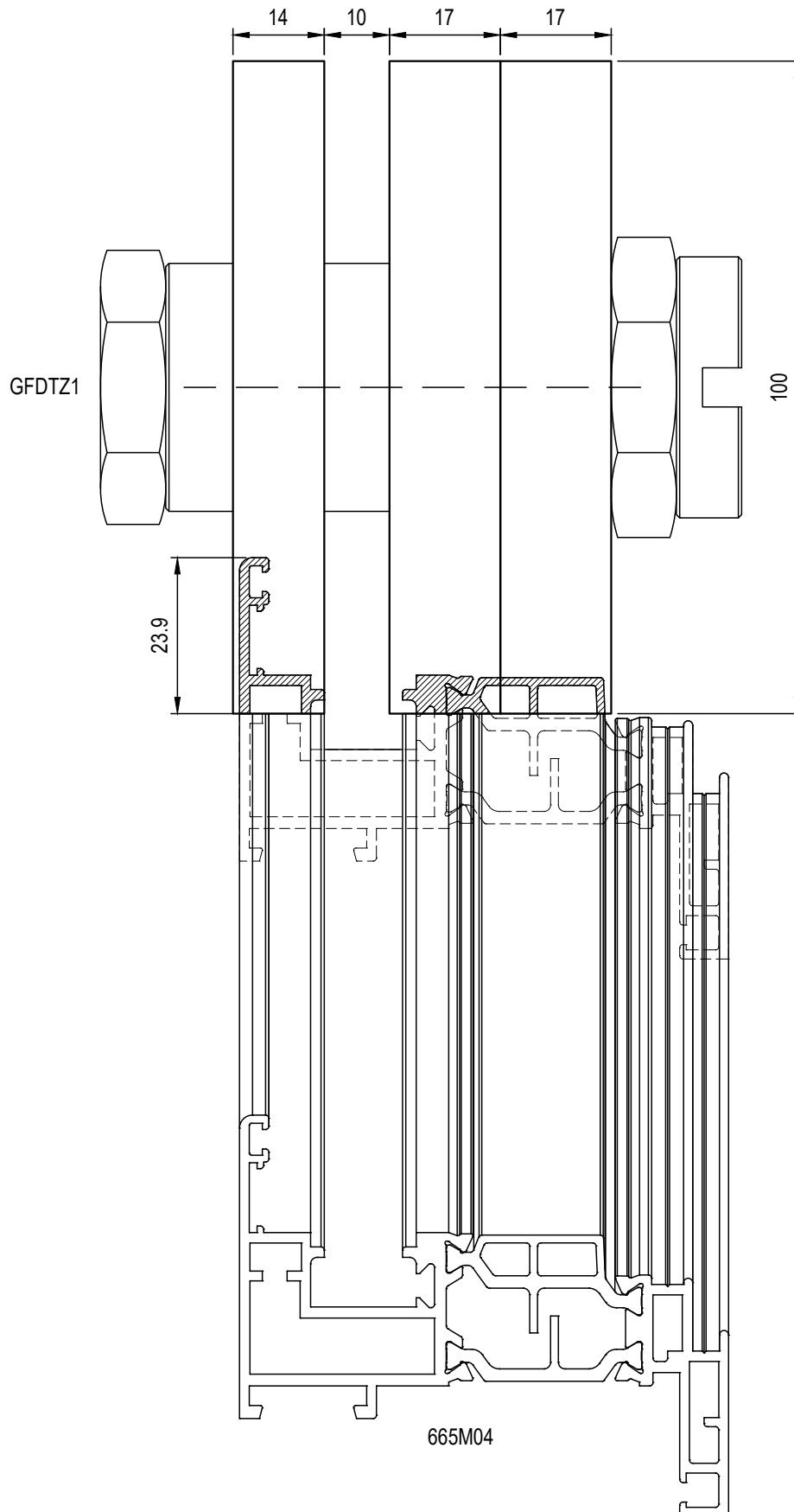

LAVORAZIONE PER INCONTRO CENTRALE
SOLUZIONE T-Z PISTA 16
DA ESEGUIRE CON GRUPPO FRESA GFDTZ4

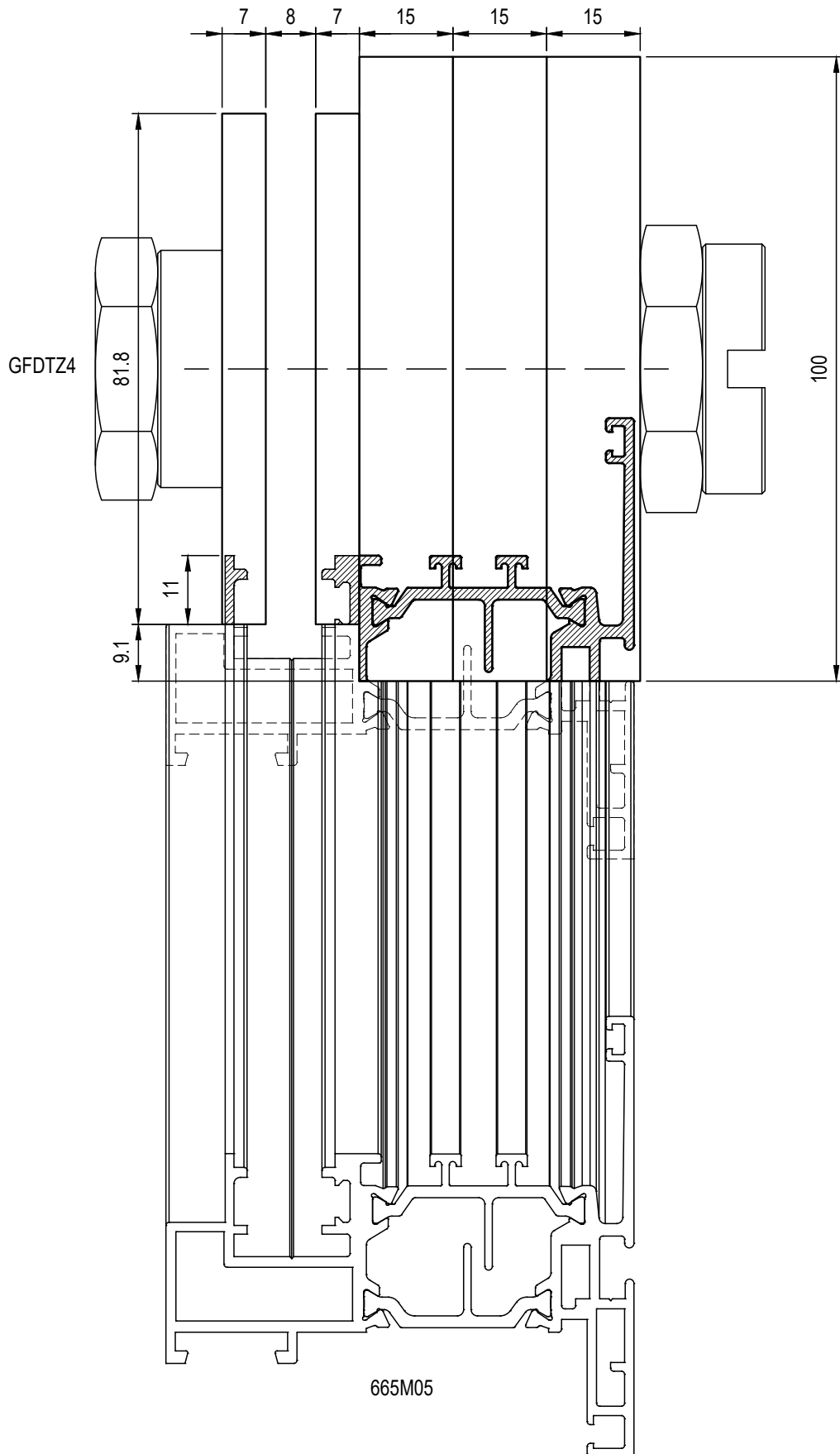

LAVORAZIONE PER INCONTRO CENTRALE T-Z PISTA 16

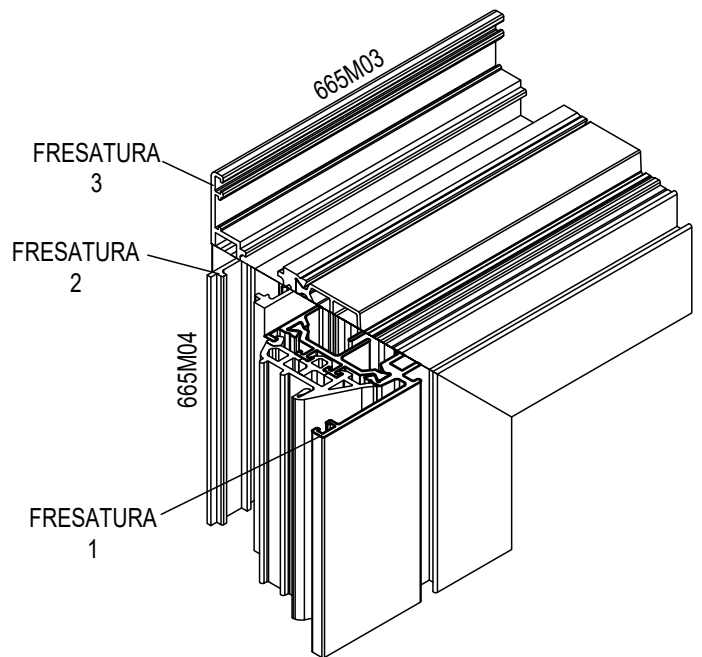
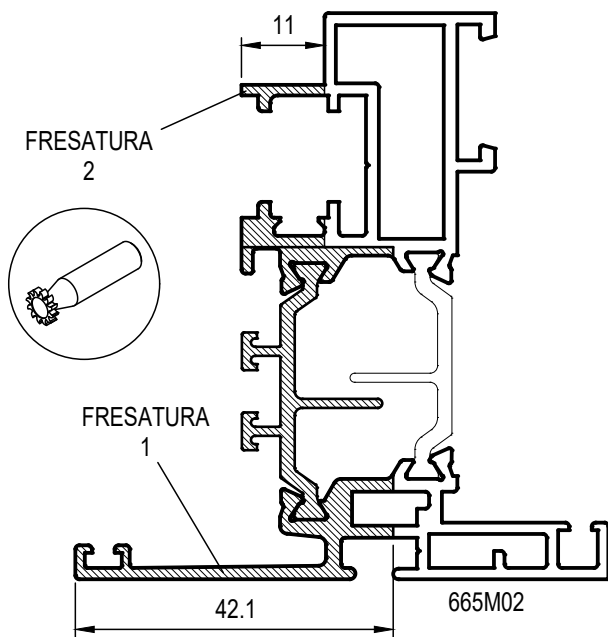
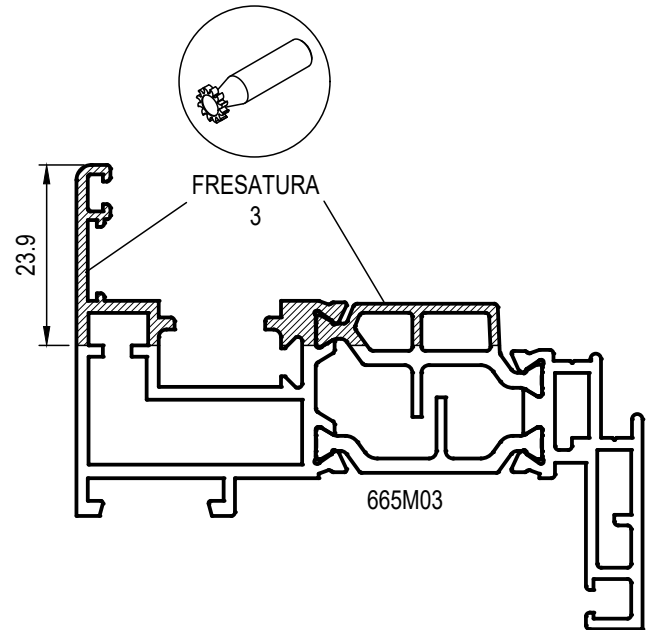
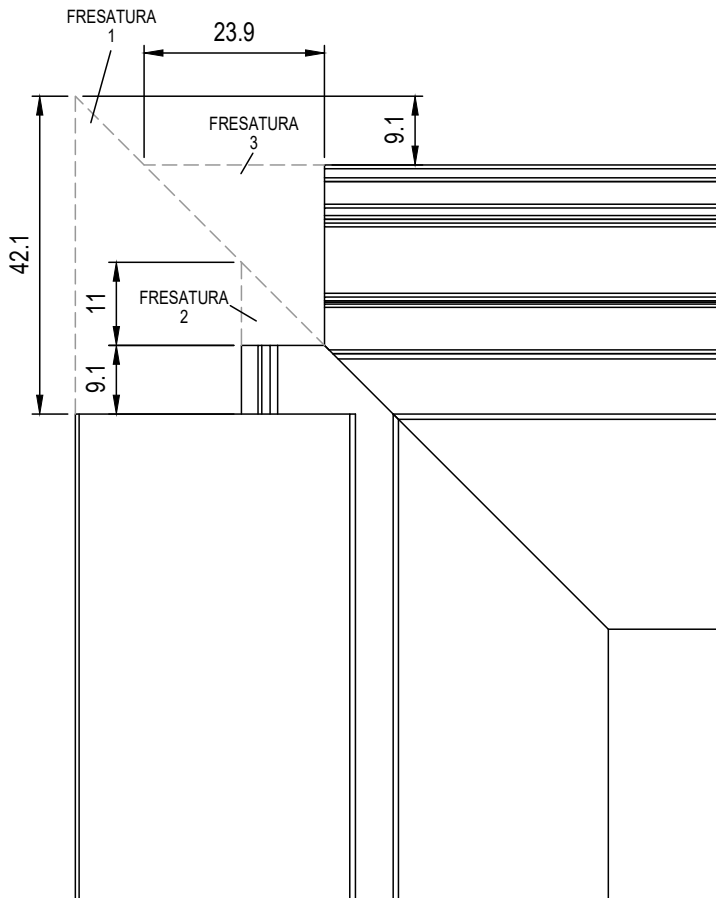

 PARTI DA FRESARE

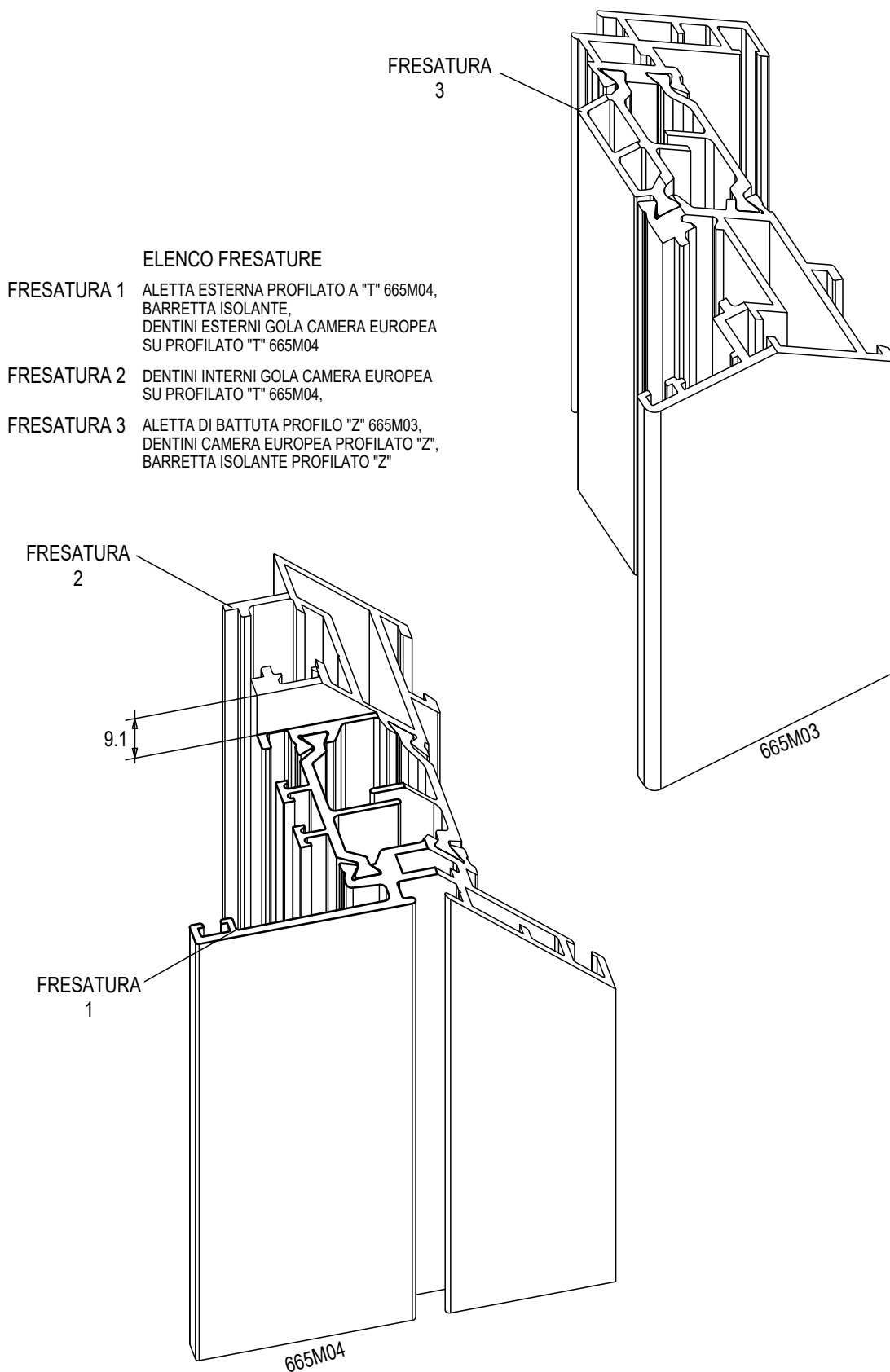

ASSEMBLAGGIO INCONTRO CENTRALE T-Z PISTA 16

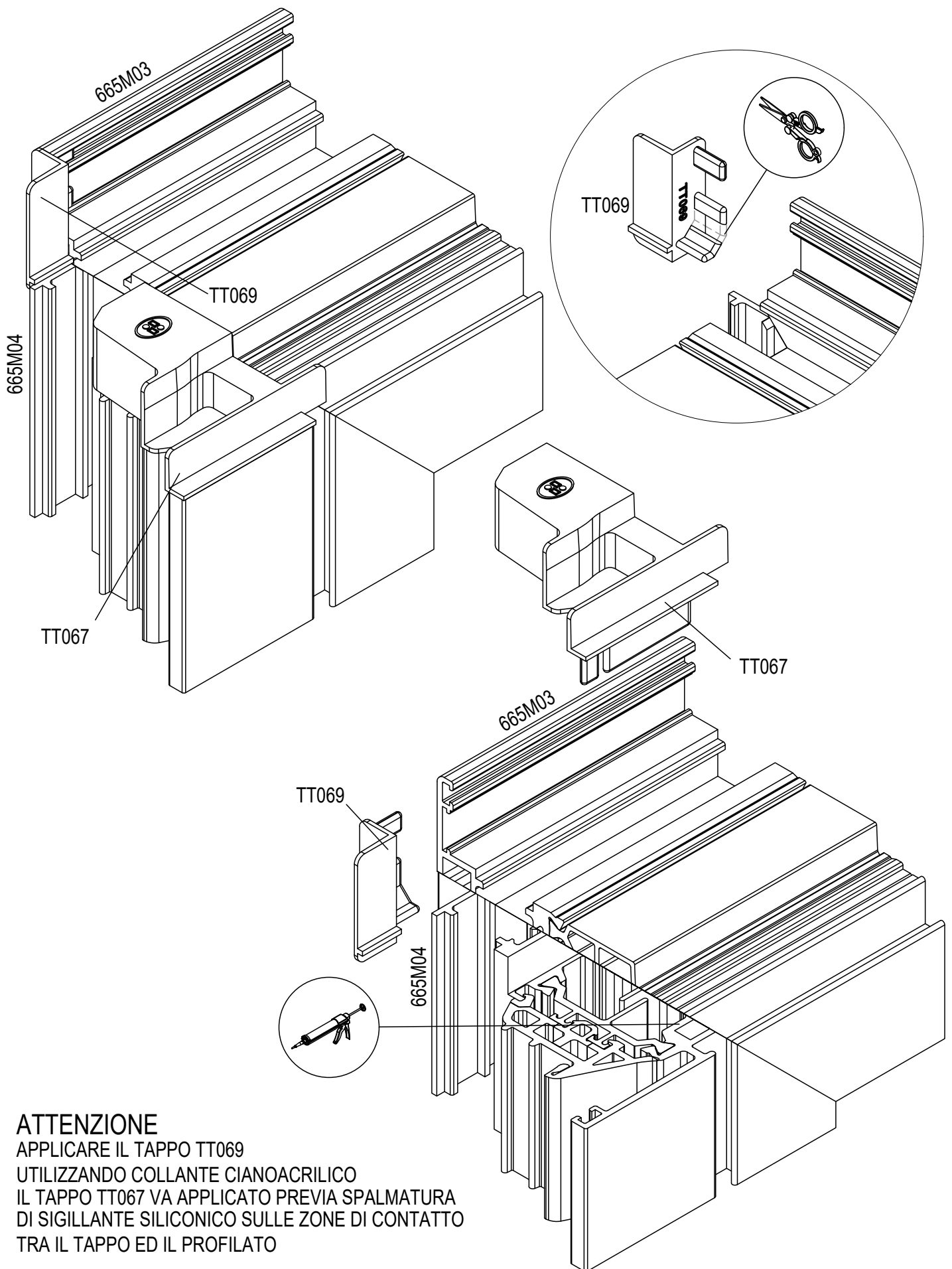

ATTENZIONE

APPLICARE IL TAPPO TT069
UTILIZZANDO COLLANTE CIANOACRILICO
IL TAPPO TT067 VA APPLICATO PREVIA SPALMATURA
DI SIGILLANTE SILICONICO SULLE ZONE DI CONTATTO
TRA IL TAPPO ED IL PROFILATO

FORO DI TESTA Ø8 E
INTERMEDIO Ø8 SU ASTINA
DI CHIUSURA

6405

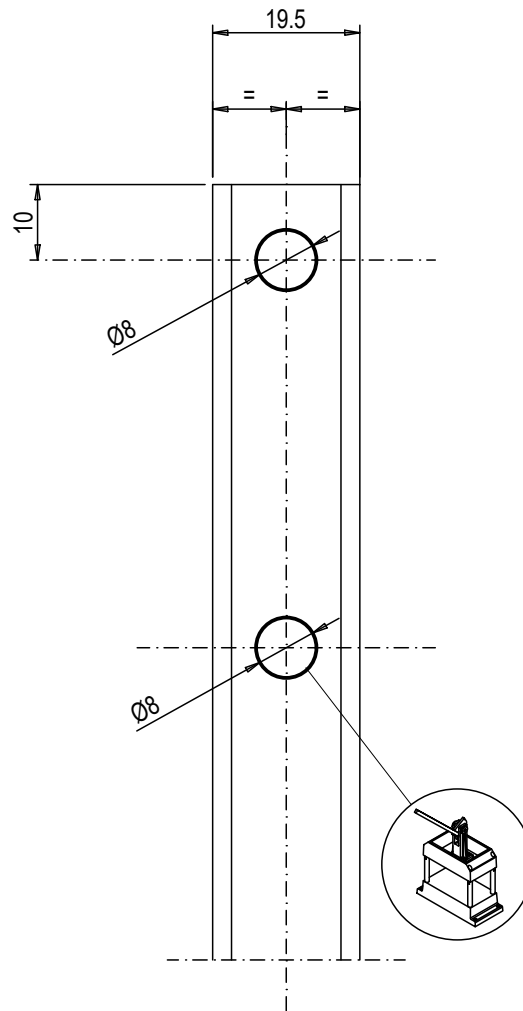

LAVORAZIONE DI SPUNTATURA ALETE
PER PASSAGGIO ASTINA
DA ESEGUIRE CON TRACIANTE T1004

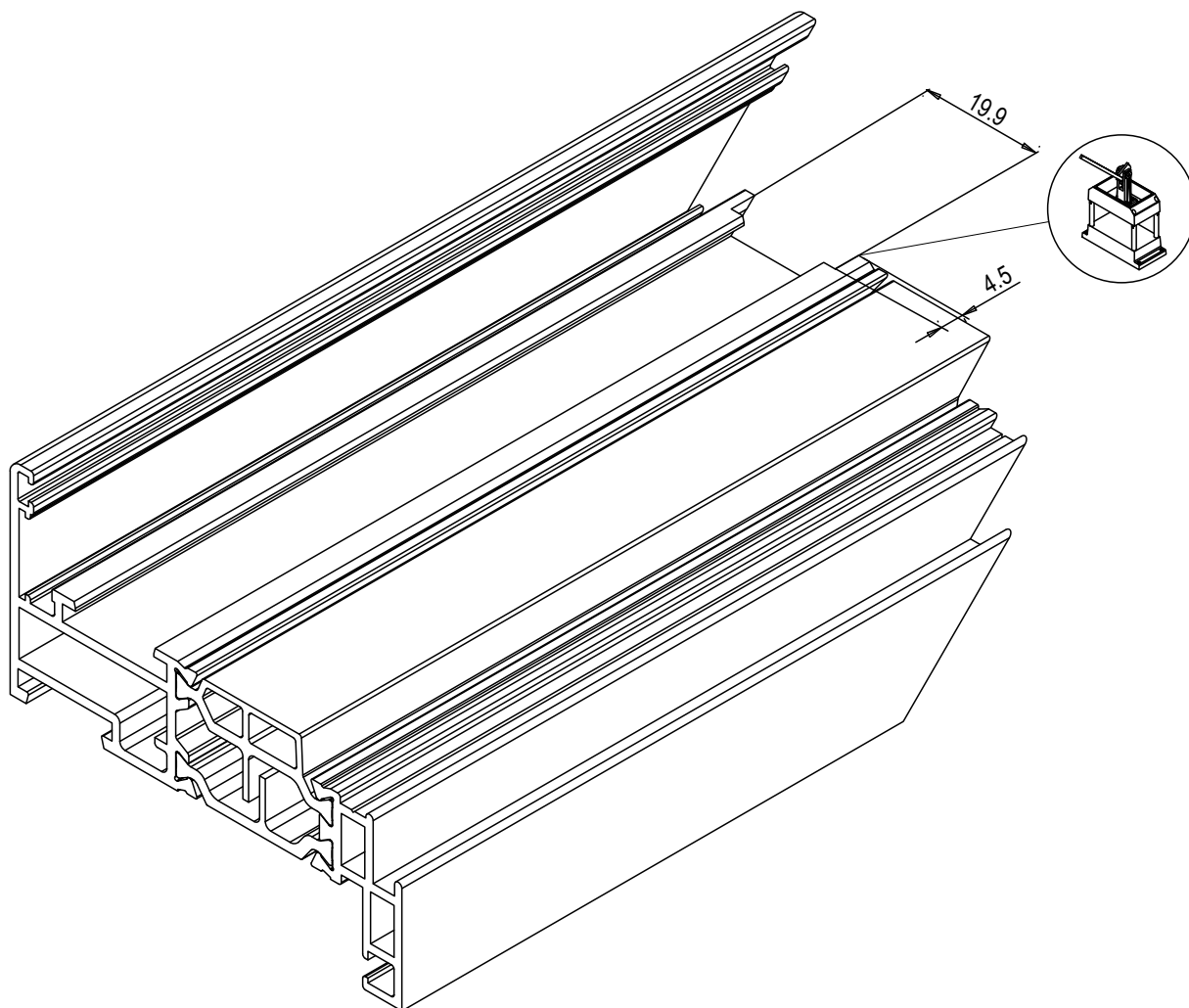

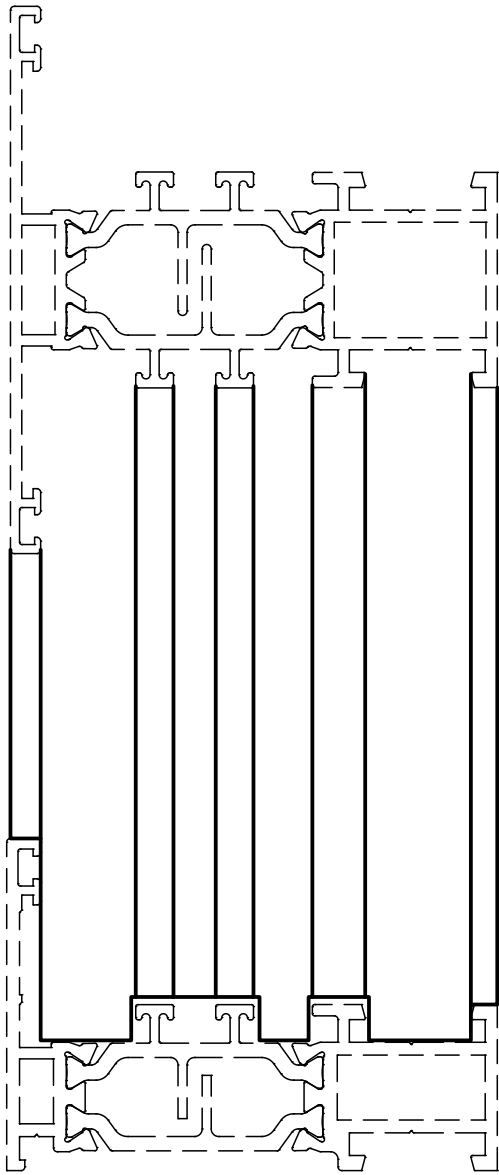

665M00

LAVORAZIONE VALIDA PER I PROFILATI

665M05

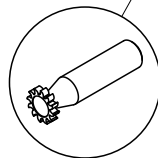
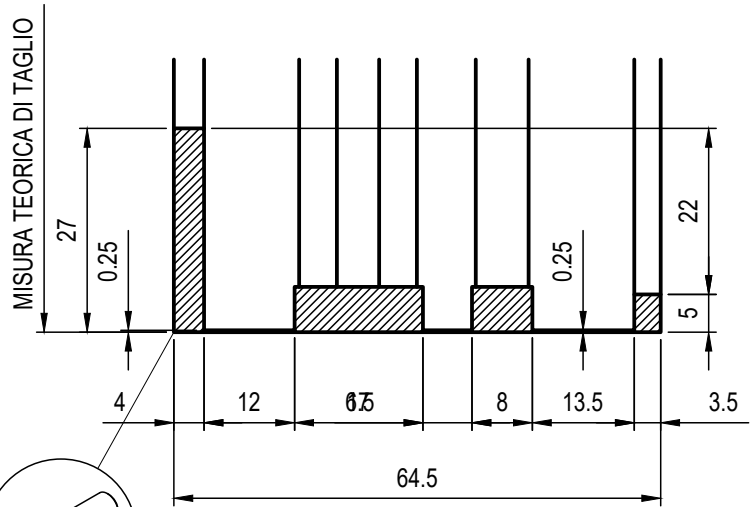
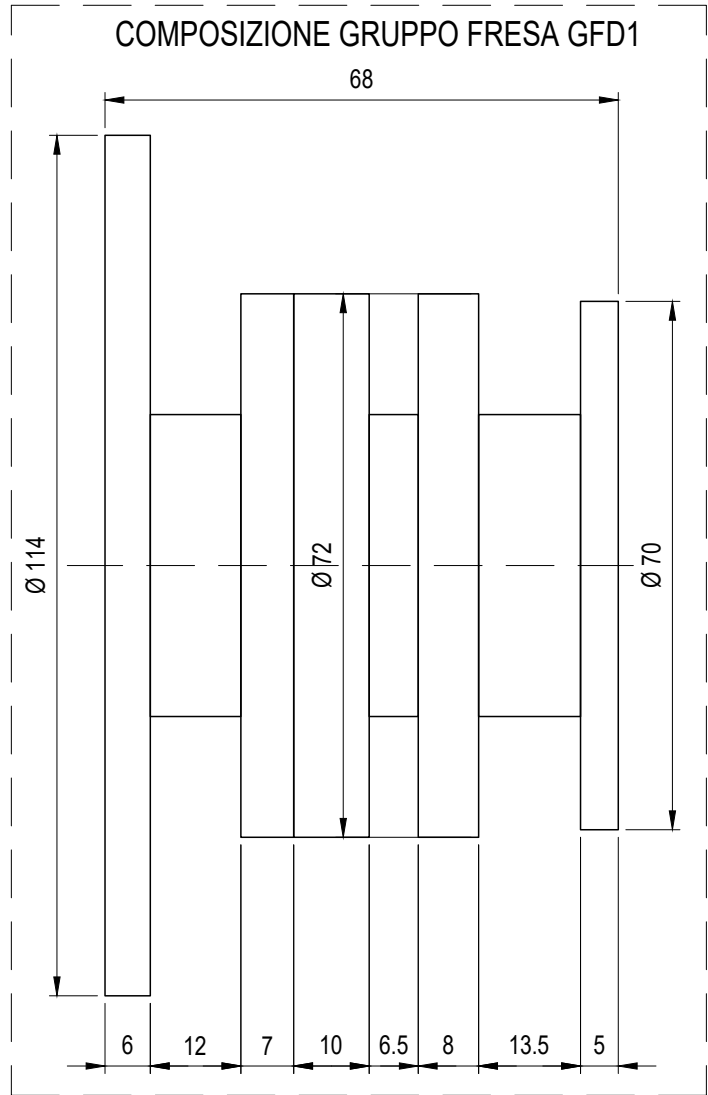

 MATERIALE DA ASPORTARE

LAVORAZIONE DI INTESTATURA TRAVERSO PER UNIONE CON ANTA CAMERA EUROPEA

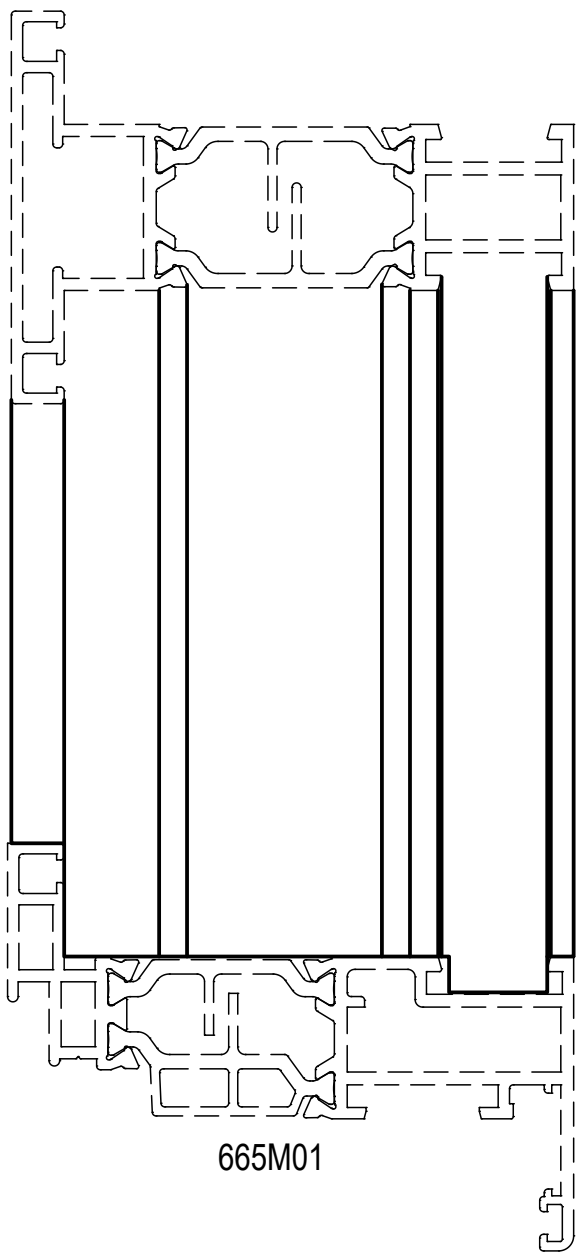

665M01

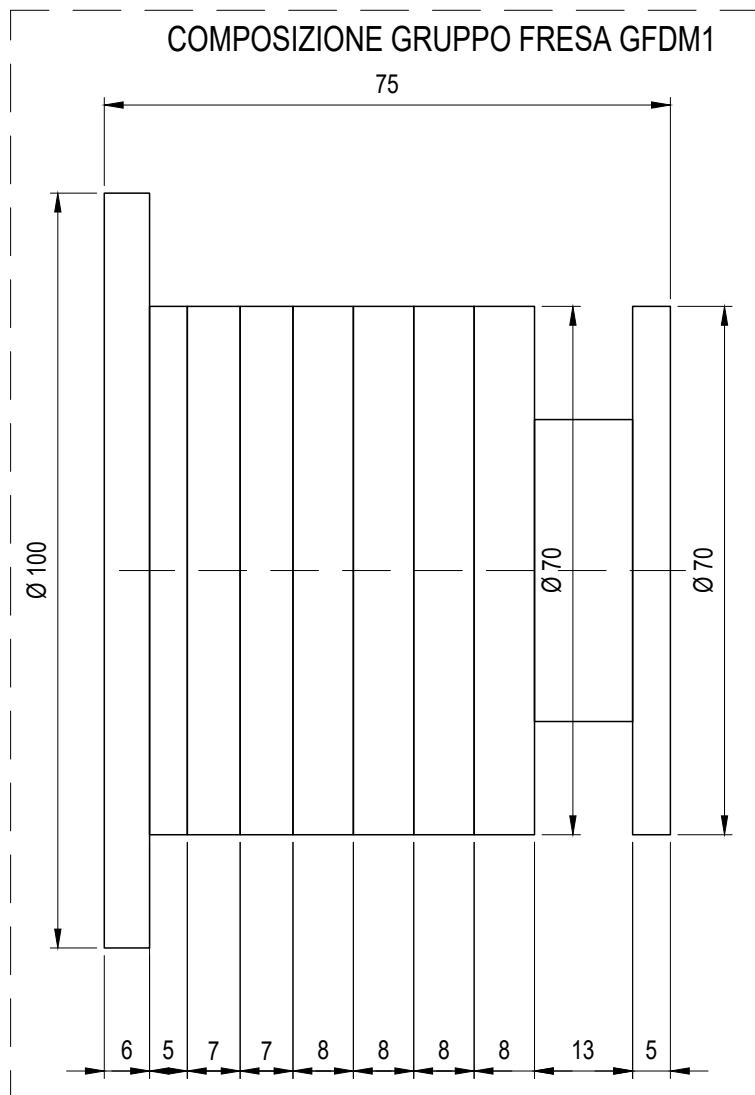

LAVORAZIONE VALIDA PER I PROFILATI

665M02

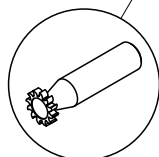
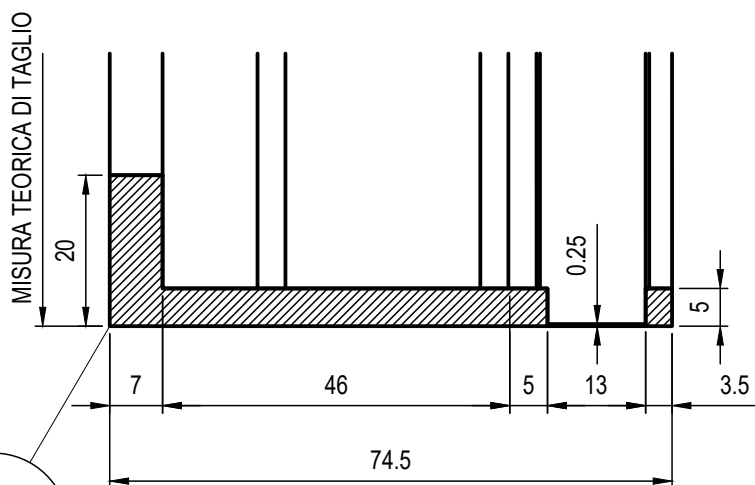

 MATERIALE DA ASPORTARE

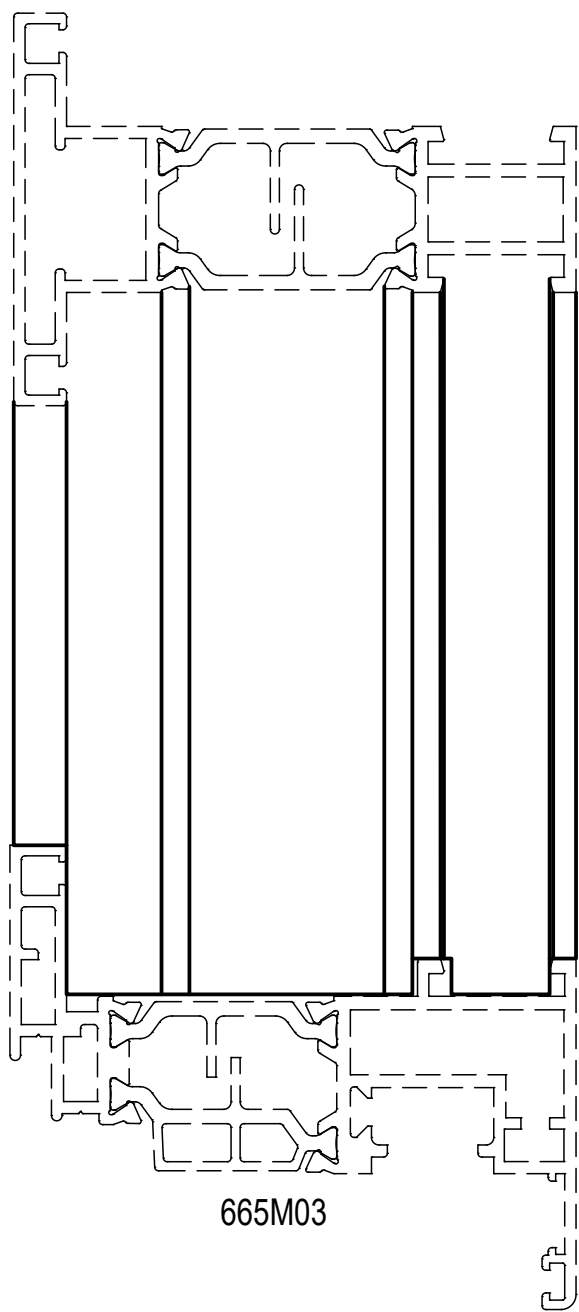

665M03

LAVORAZIONE VALIDA PER I PROFILATI

665M04

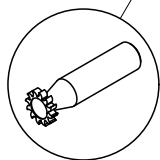
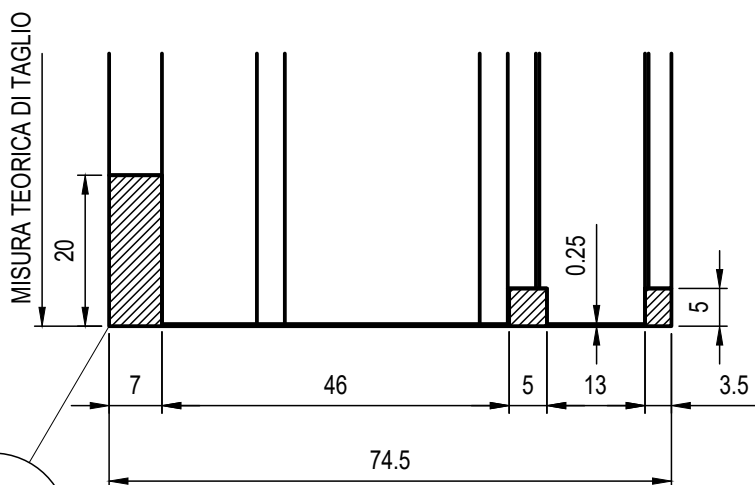
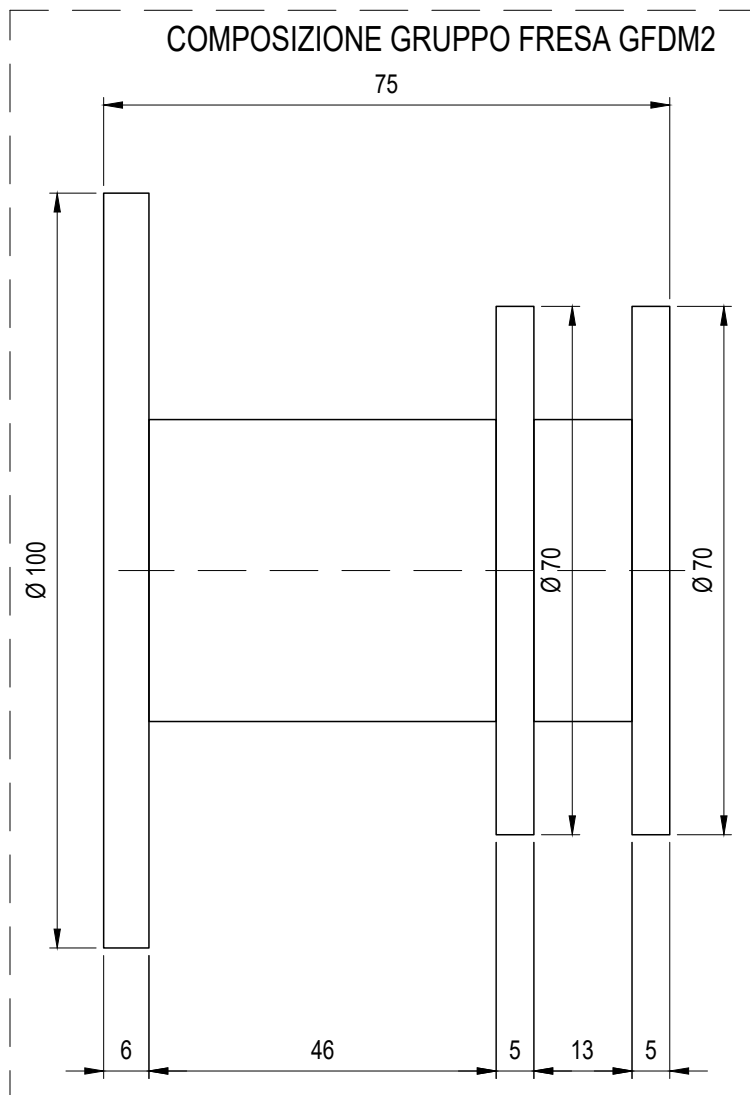

MATERIALE DA ASPORTARE

LAVORAZIONE TRAVERSO ART. 665020
 PER CAVALLOTTO INTERNO ART. G199
 DA ESEGUIRE CON TRACIANTE TI002 E DIMA GA108

FISSAGGIO CON VITE

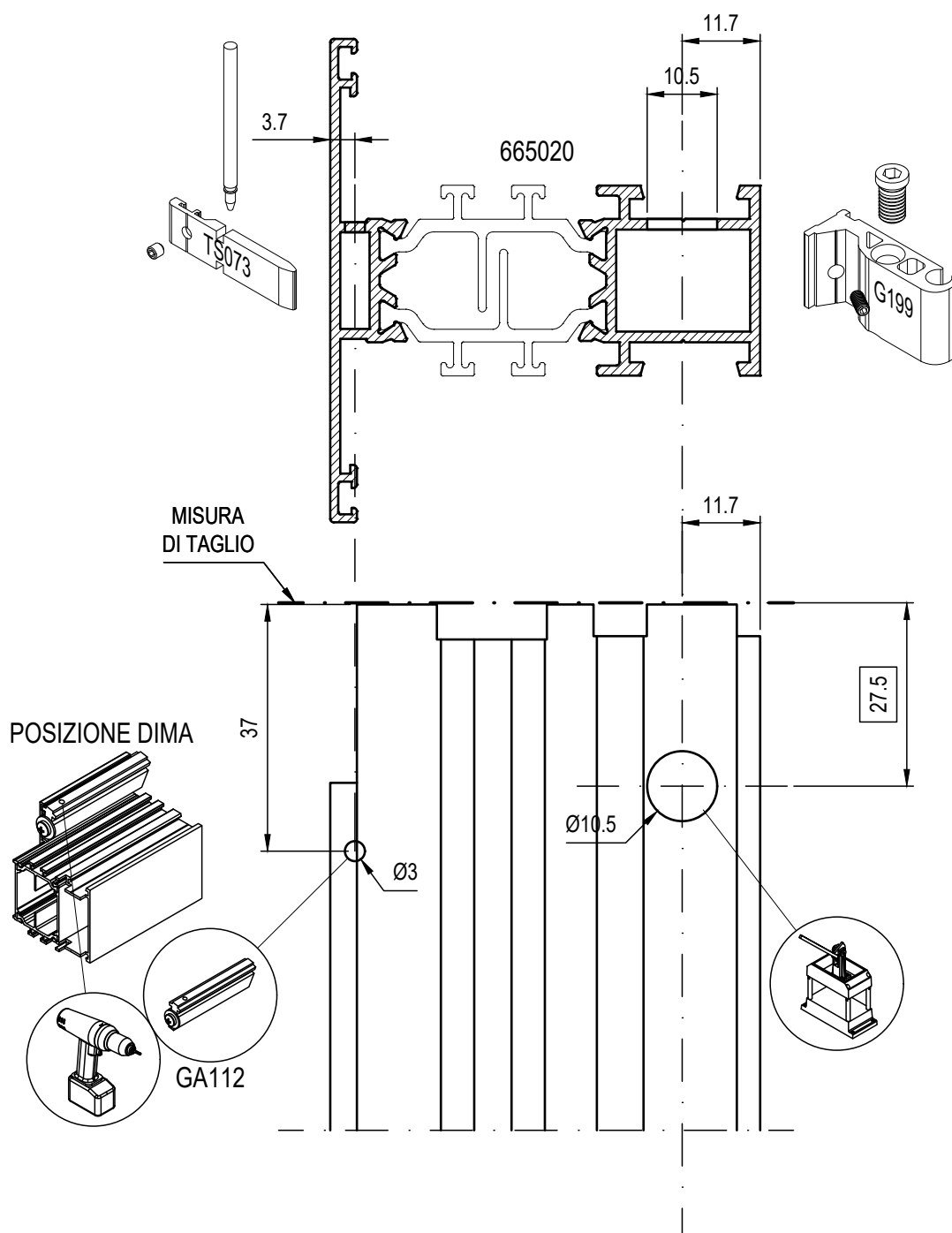

LAVORAZIONE TRAVERSO ART. 665020
 PER CAVALLOTTO INTERNO ART. G199
 DA ESEGUIRE CON TRACIANTE TI002 E DIMA GA108



FISSAGGIO CON SPINA

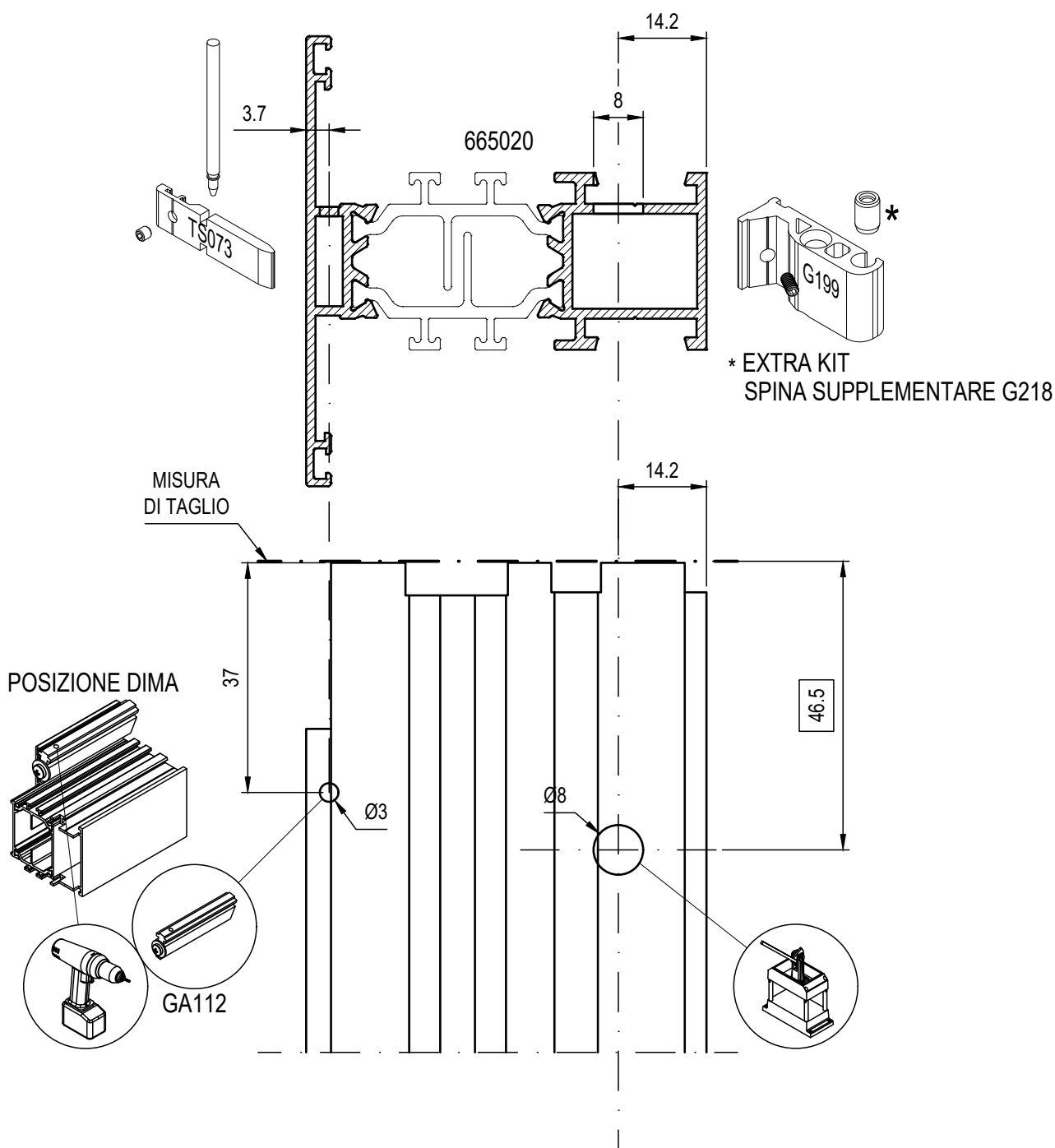

LAVORAZIONE TRAVERSO ART. 665M07
PER CAVALLOTTO INTERNO ART. TS090

FISSAGGIO CON VITE

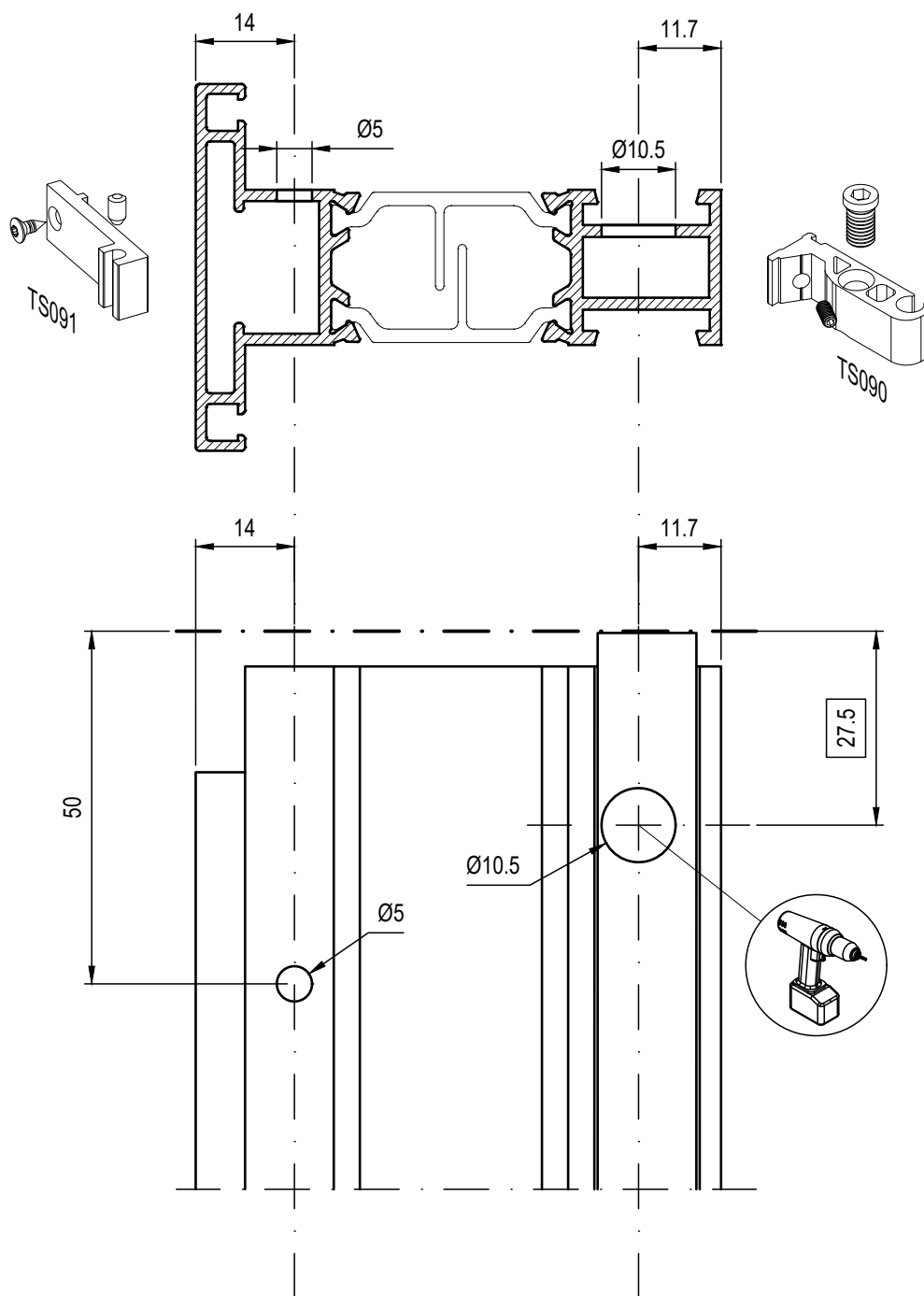

FISSAGGIO CON SPINA

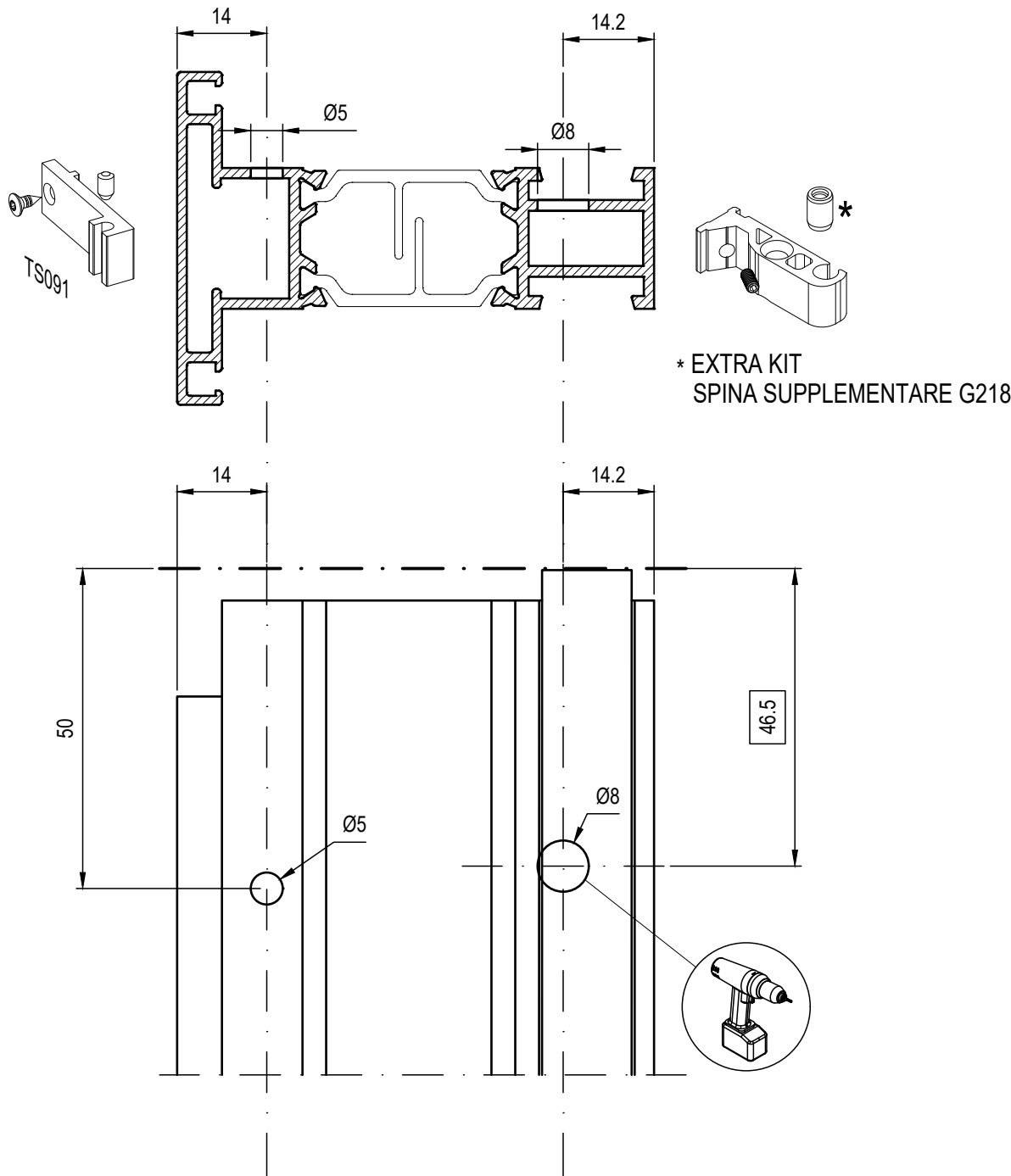

SCHEMA DI ASSEMBLAGGIO
TRAVERSO SU TELAIO

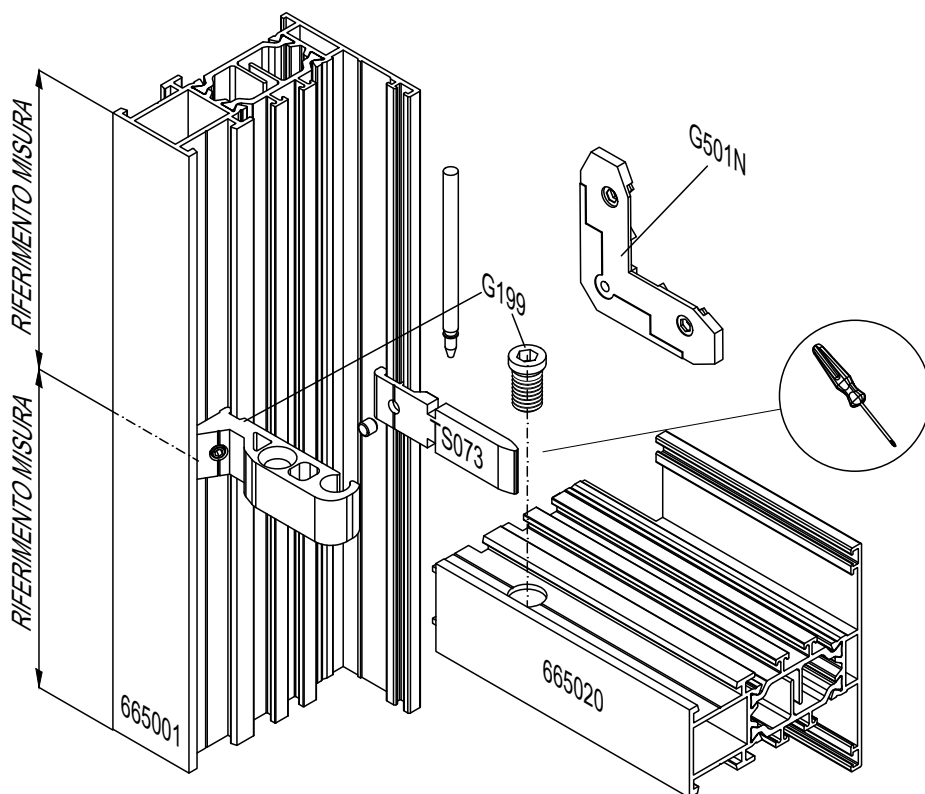

FISSAGGIO CON VITE

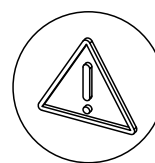
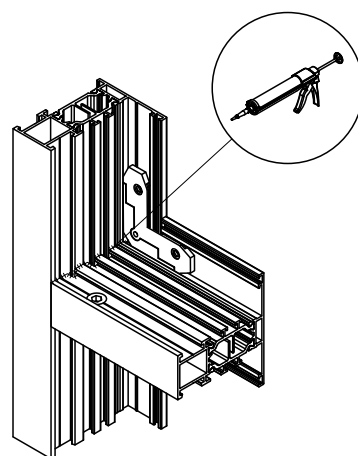

INSERIRE GUARNIZIONE
CINGIVETRO ESTERNA

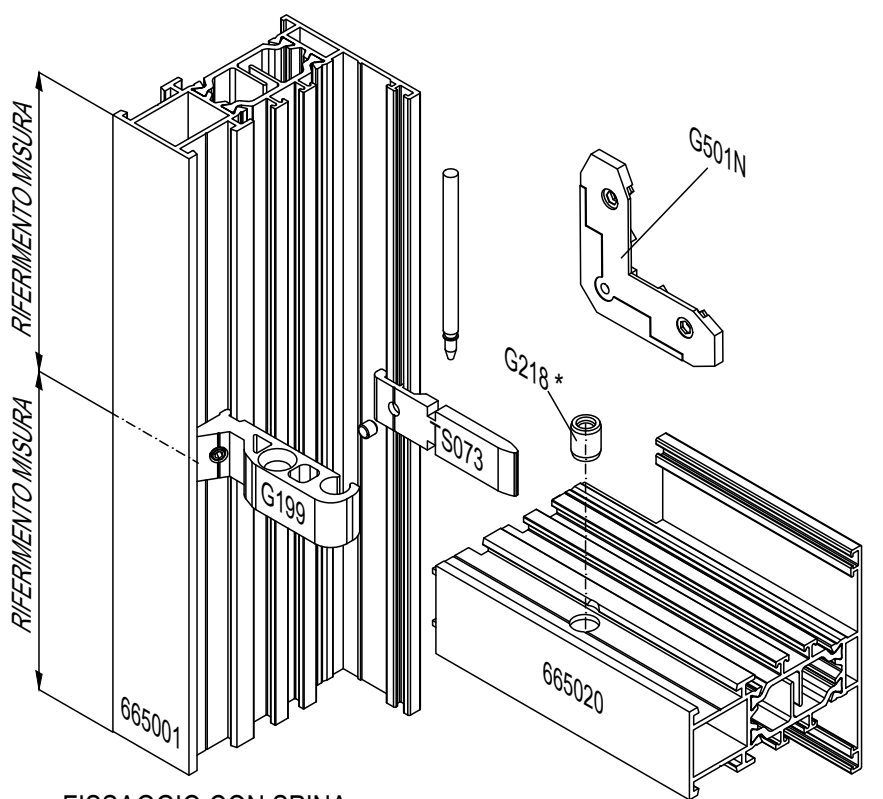

FISSAGGIO CON SPINA

* EXTRA KIT

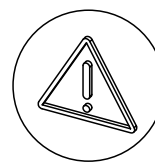
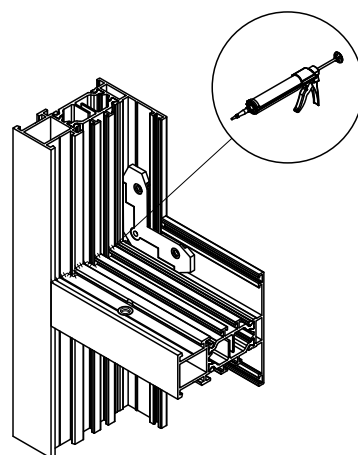

INSERIRE GUARNIZIONE
CINGIVETRO ESTERNA

SCHEMA DI ASSEMBLAGGIO
TRAVERSO SU ANTA

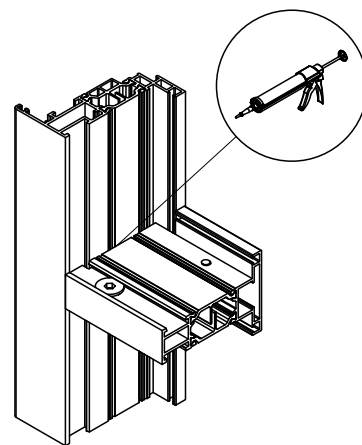
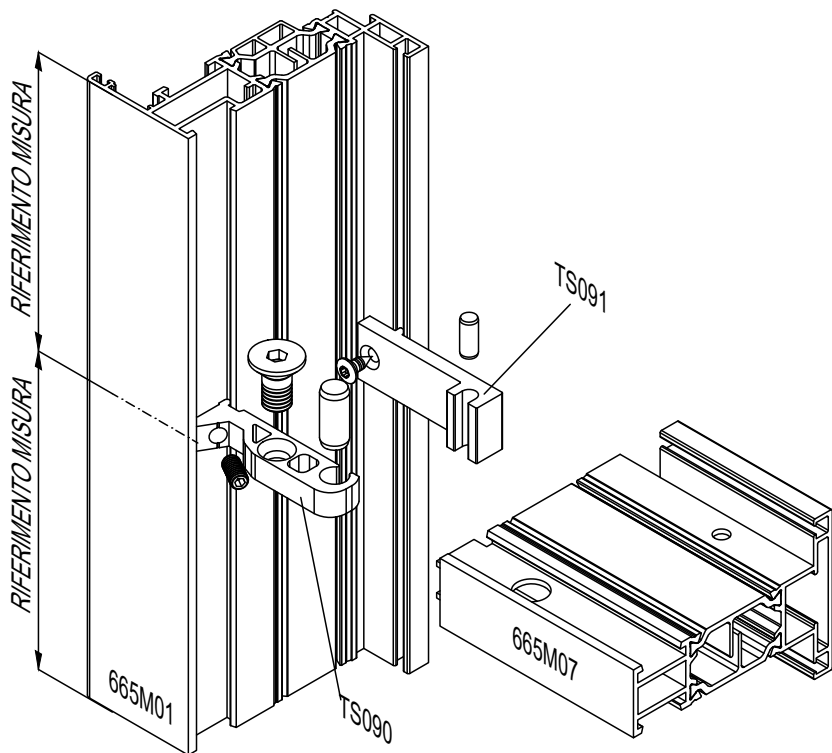

FISSAGGIO CON VITE

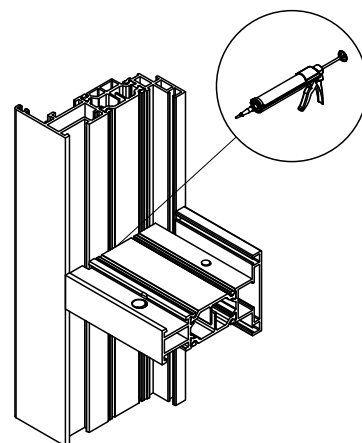
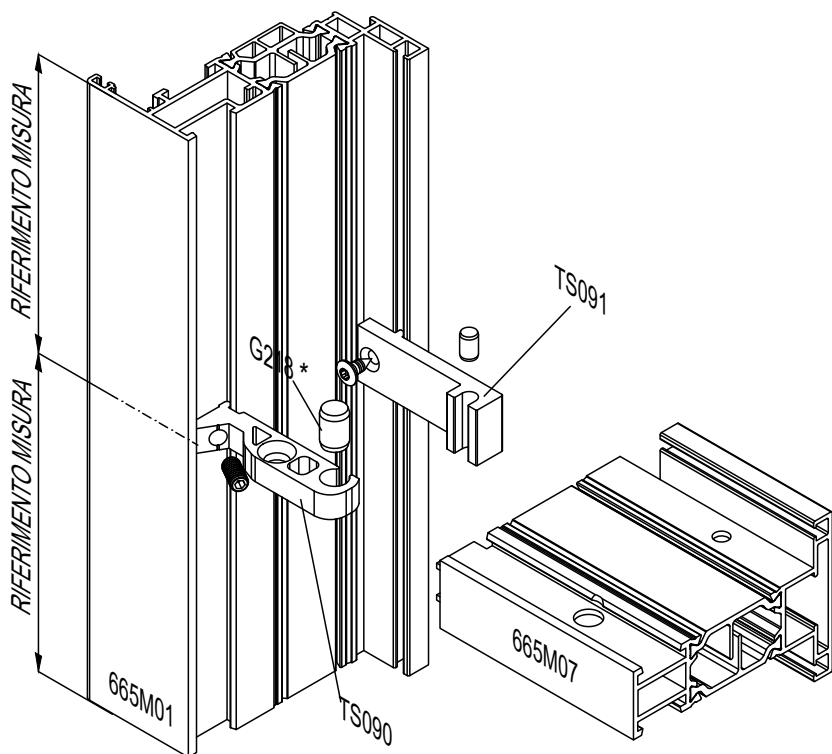

FISSAGGIO CON SPINA

* EXTRA KIT

LAVORAZIONE SCARICO ACQUA TELAIO FISSI E AERAZIONE ANTE APRIBILI DA ESEGUIRE CON TRACIANTE TI005

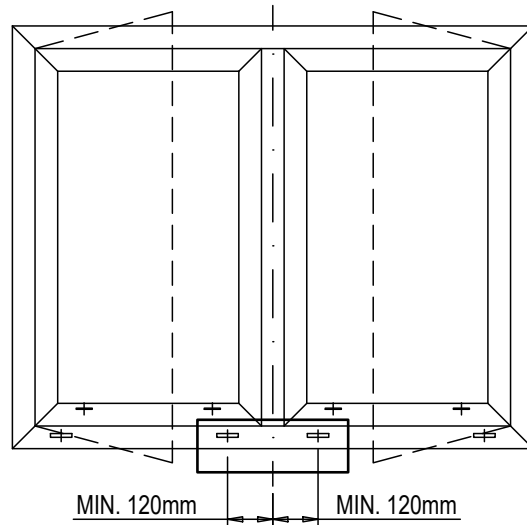
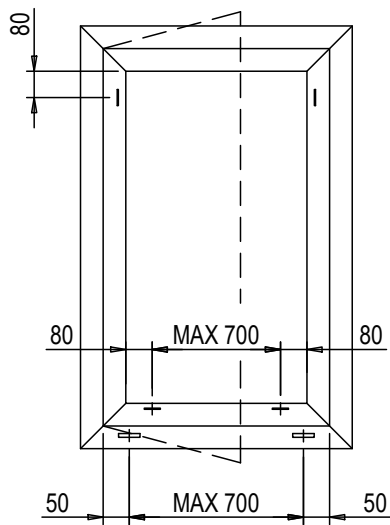

NEL CASO DI FINESTRE
A DUE O PIU' ANTE,
PREVEDERE SCARICHI
ACQUA A DX E SX
DELLA SEZIONE CENTRALE,
COME INDICATO A FIANCO

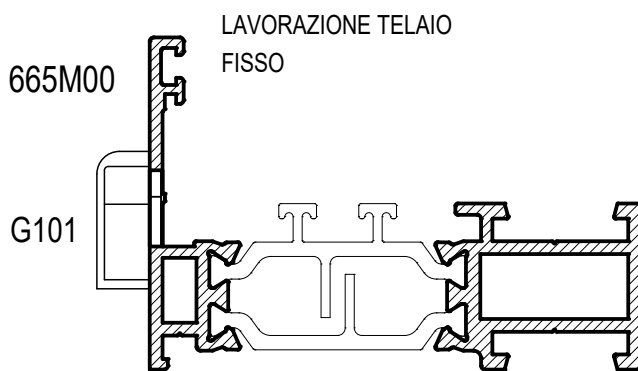

X = 14 mm CON GA003
X = 18 mm CON GA101

SCARICO ACQUA

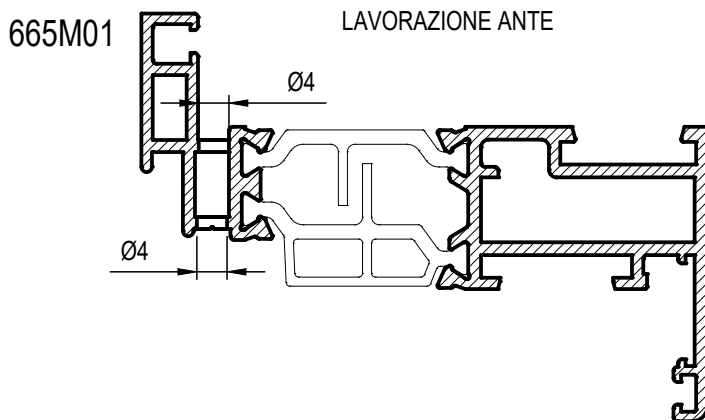
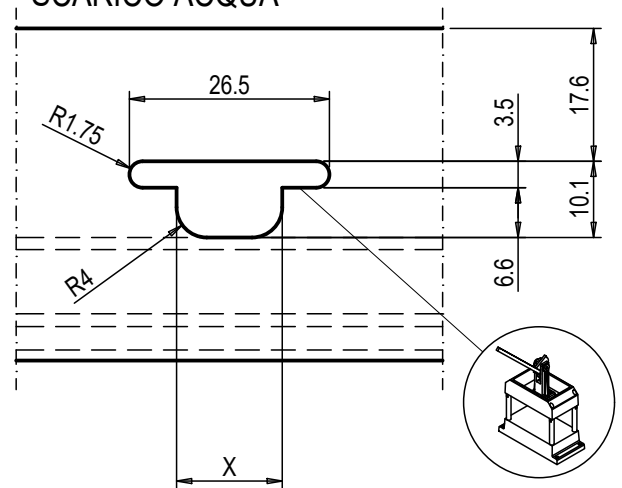

AERAZIONE VETRO

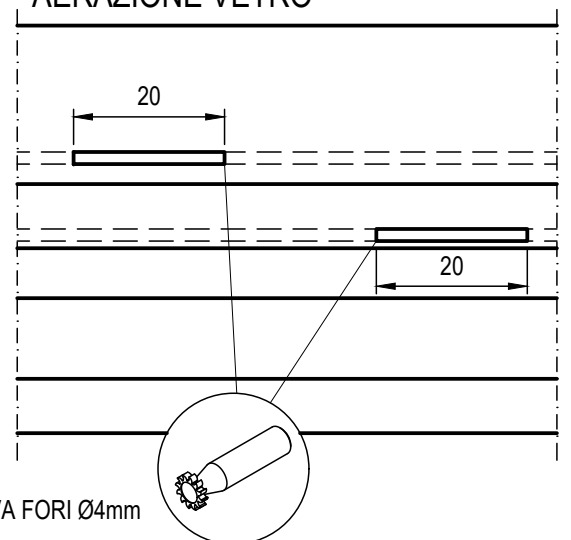

IN ALTERNATIVA FORI Ø4mm

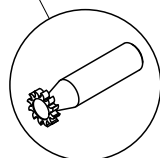
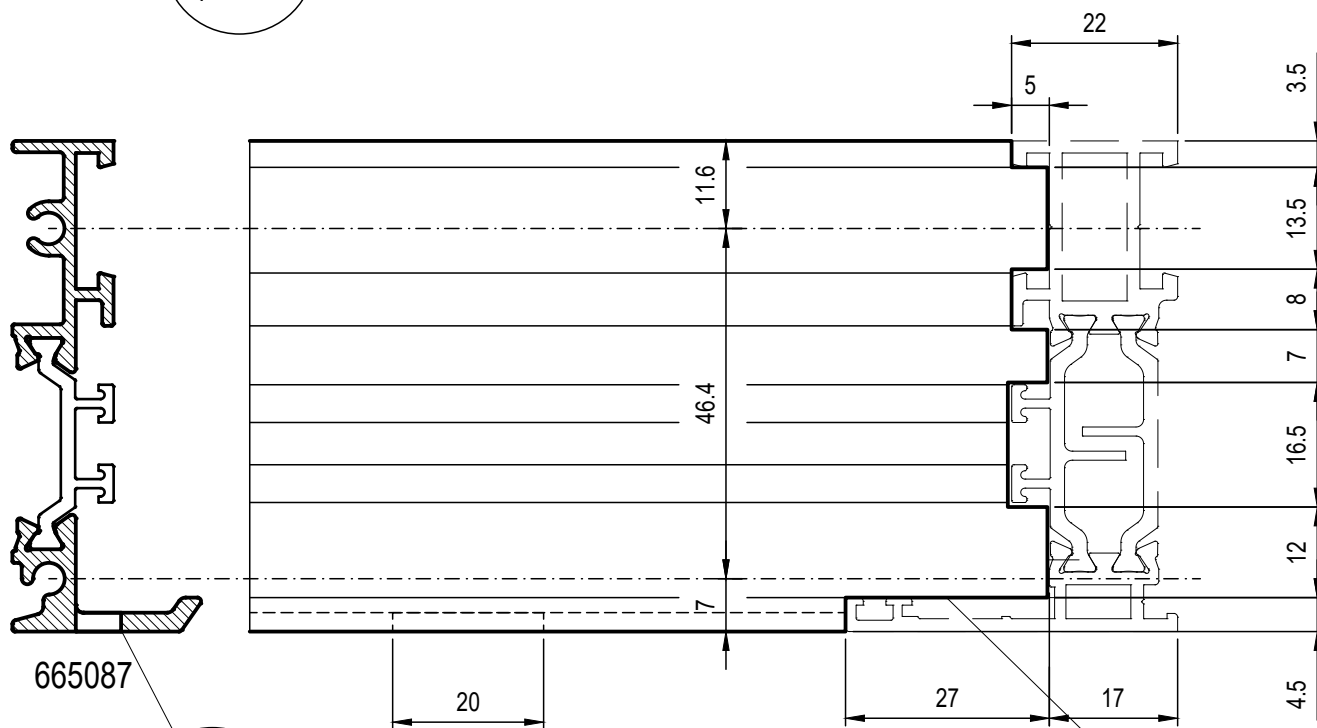
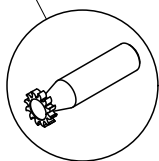
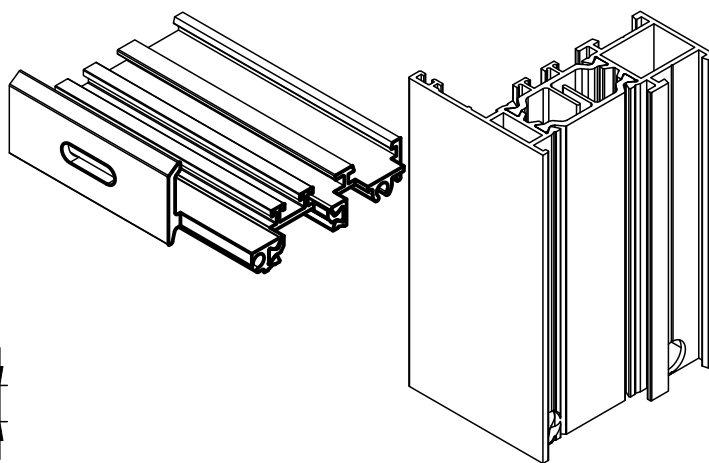
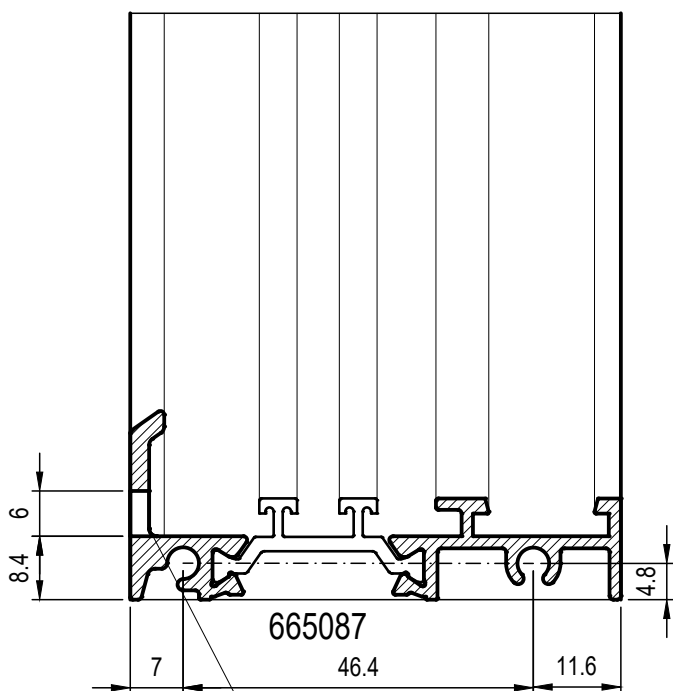

ASOLA DRENAGGIO 6x20 mm

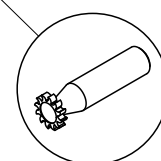

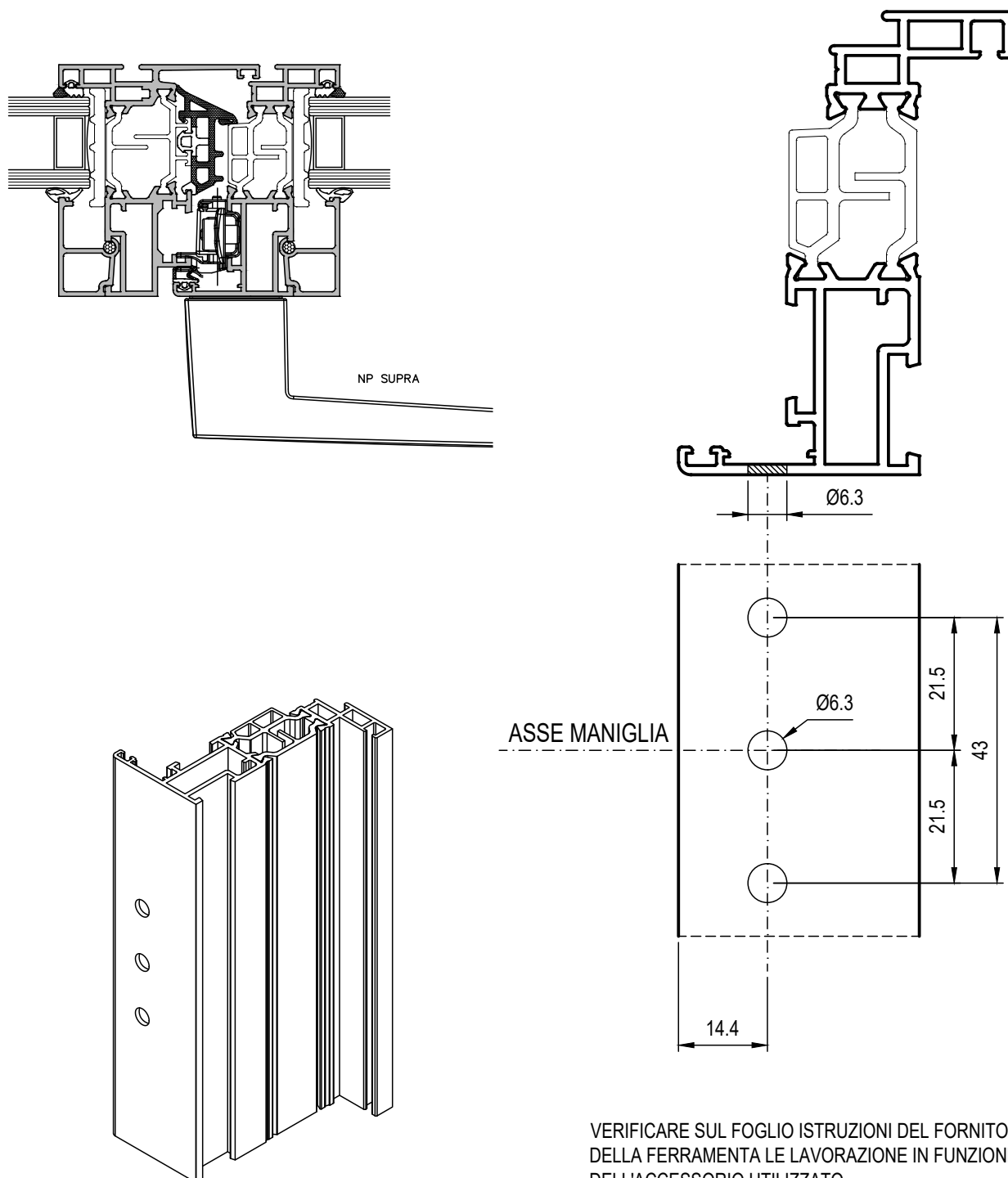

VERIFICARE SUL FOGLIO ISTRUZIONI DEL FORNITORE DELLA FERRAMENTA LE LAVORAZIONE IN FUNZIONE DELL'ACCESSORIO UTILIZZATO.

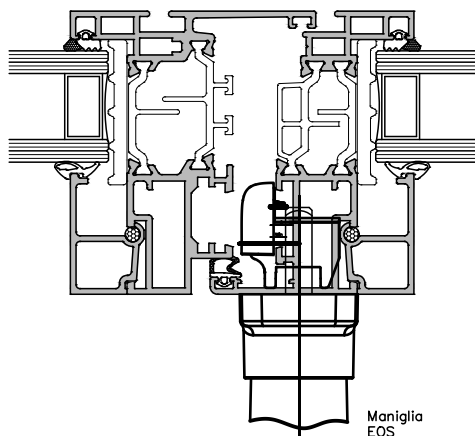

Maniglia
EOS
Art.0510A
Meccanismo
Art.0520

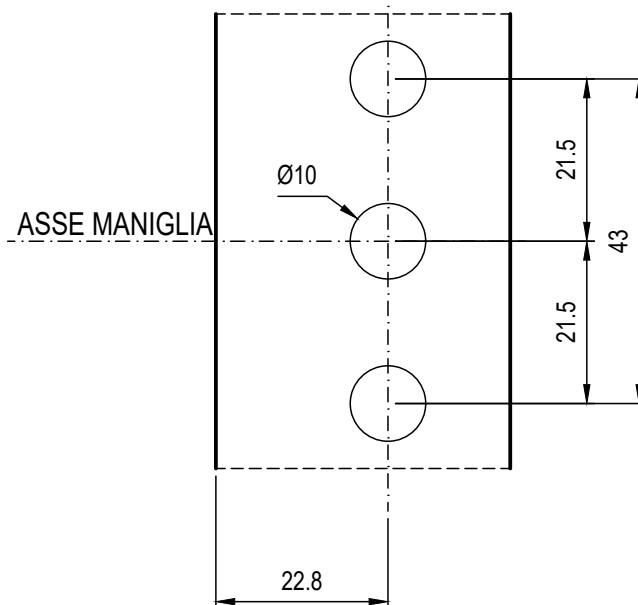
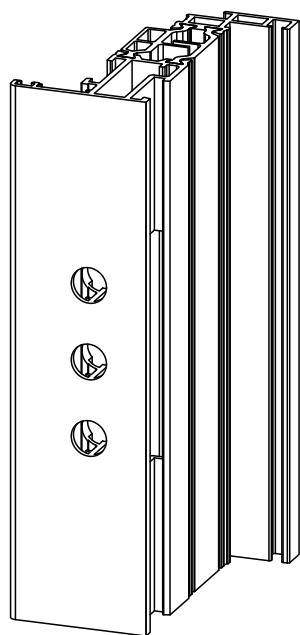
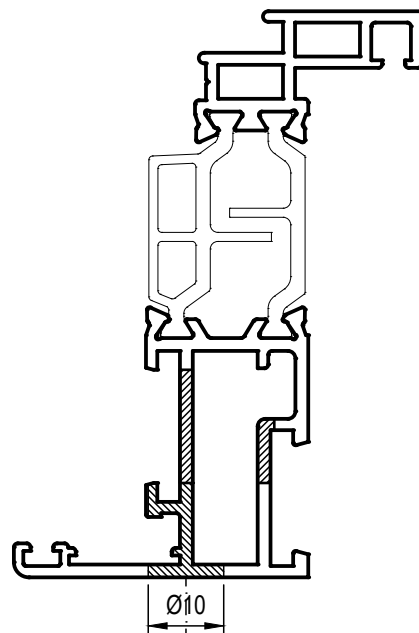

VERIFICARE SUL FOGLIO ISTRUZIONI DEL FORNITORE DELLA FERRAMENTA LE LAVORAZIONE IN FUNZIONE DELL'ACCESSORIO UTILIZZATO.

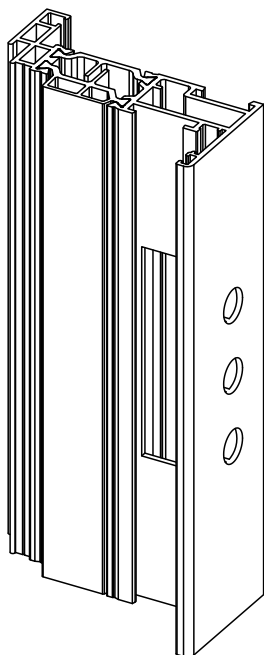

ASSE MANIGLIA

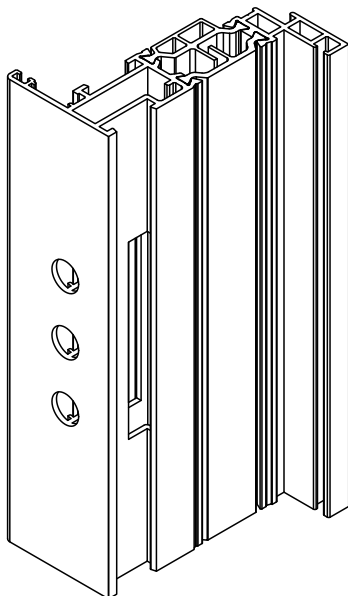
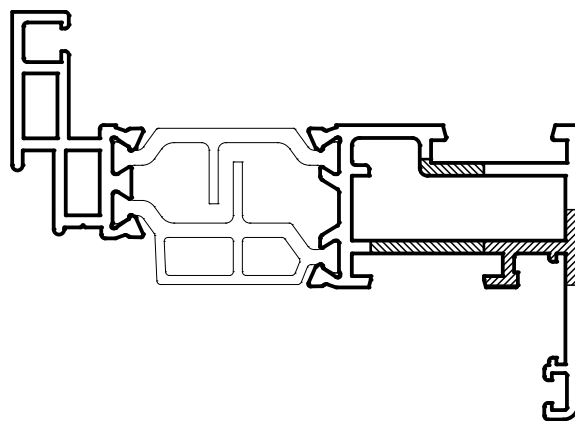
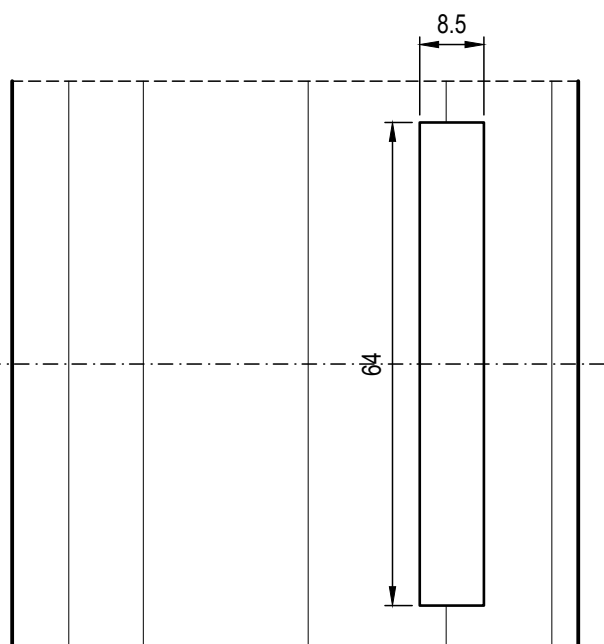

ASSE MANIGLIA

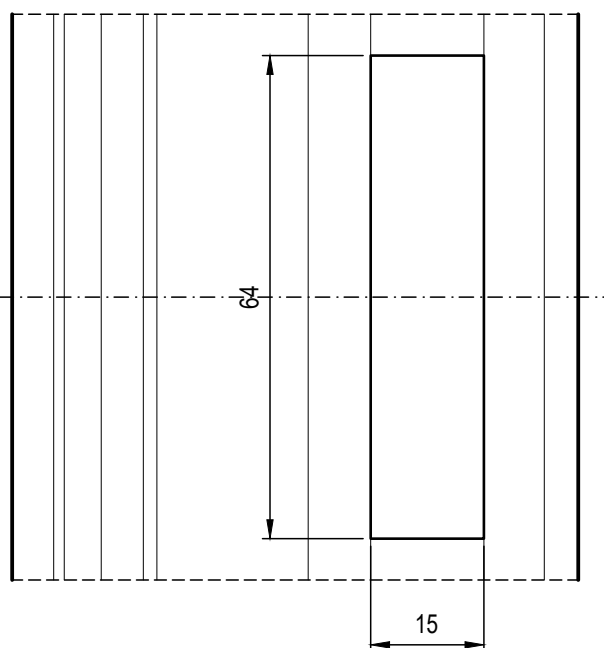

VERIFICARE SUL FOGLIO ISTRUZIONI DEL FORNITORE DELLA FERRAMENTA LE LAVORAZIONE IN FUNZIONE DELL'ACCESSORIO UTILIZZATO.

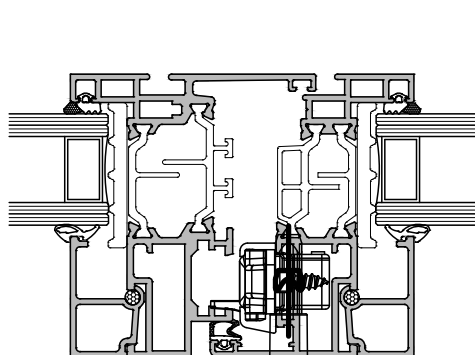

Maniglia
Art.309X.XX
Meccanismo
Art.3636.XX

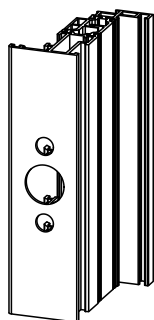
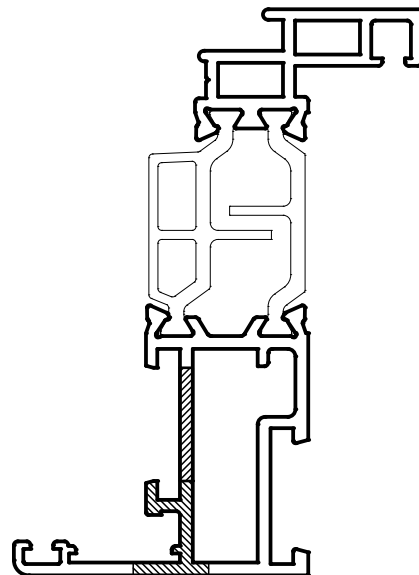

VARIANTE "A"

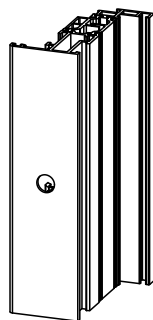

VARIANTE "B"

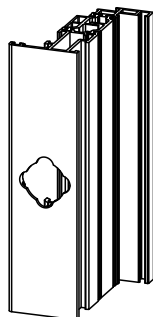

VARIANTE "C"

ASSE MANIGLIA
VARIANTE "A"

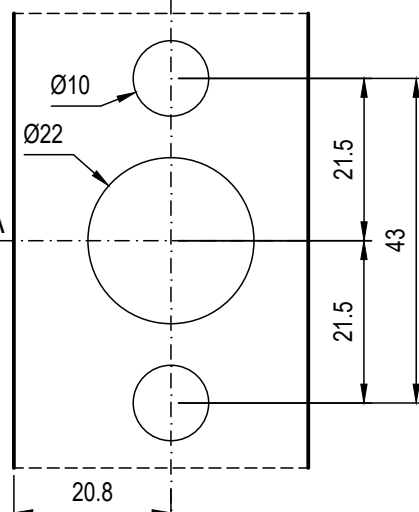

ASSE MANIGLIA
VARIANTE "B"

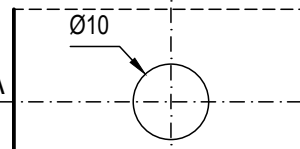

ASSE MANIGLIA
VARIANTE "C"

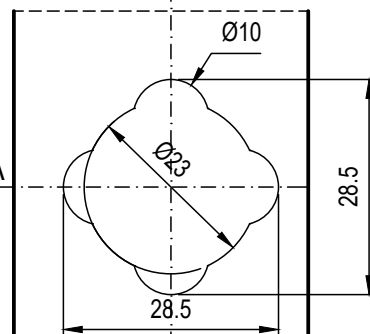

VERIFICARE SUL FOGLIO ISTRUZIONI DEL FORNITORE DELLA FERRAMENTA LE LAVORAZIONE IN FUNZIONE DELL'ACCESSORIO UTILIZZATO.

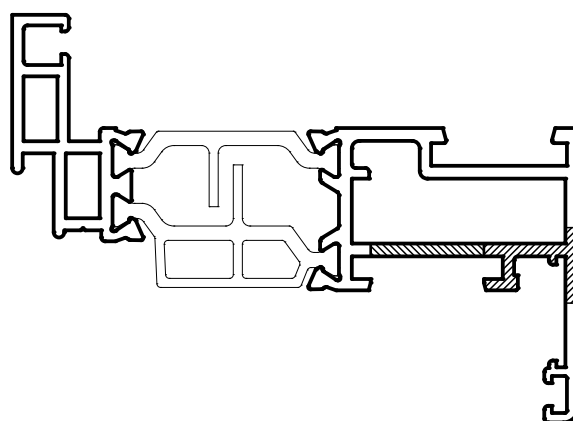
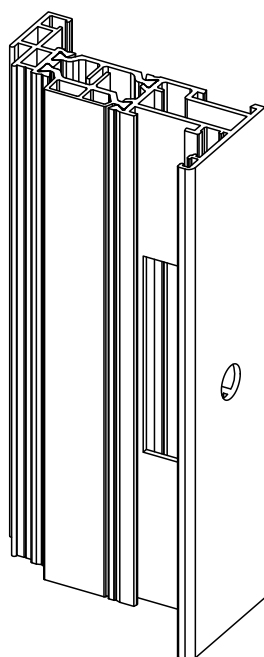

ASSE MANIGLIA

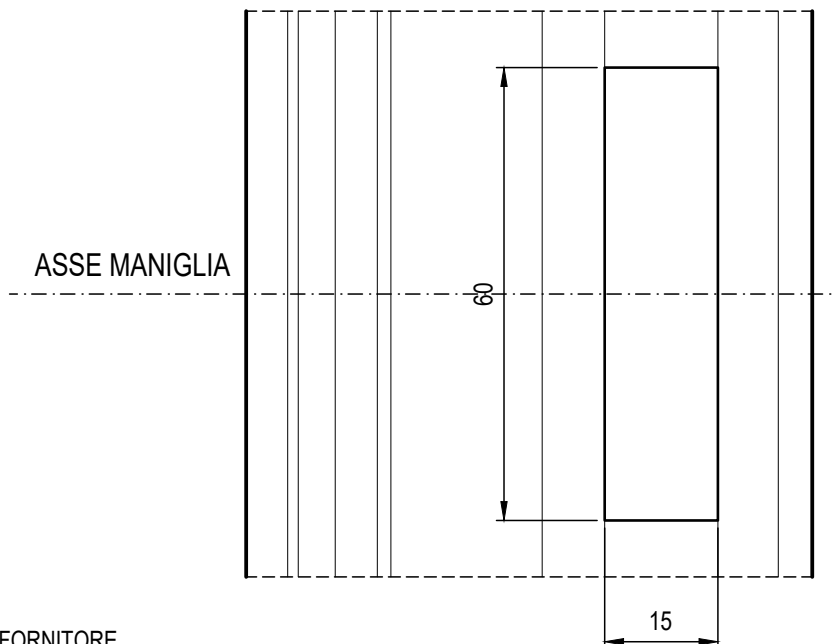

VERIFICARE SUL FOGLIO ISTRUZIONI DEL FORNITORE DELLA FERRAMENTA LE LAVORAZIONE IN FUNZIONE DELL'ACCESSORIO UTILIZZATO.



Informazioni Tecniche 

SPESSORAMENTO DEI VETRI

A SECONDA DELLA TIPOLOGIA DI INFISSO, E' CONVENIENTE EFFETTUARE LO SPESSORAMENTO DELLE VETRAZIONI SECONDO LE INDICAZIONI SEGUENTI.

UNO SPESSORAMENTO ESEGUITO CORRETTAMENTE GARANTISCE LA PERFETTA FUNZIONALITA' DI MOVIMENTAZIONE DELLE ANTE ED UNA MAGGIORE ROBUSTEZZA DEL SERRAMENTO STESSO.

TELAIO FISSO

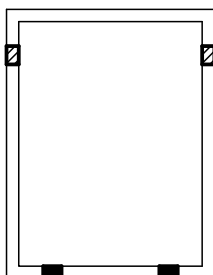

APRIBILE AD ANTA

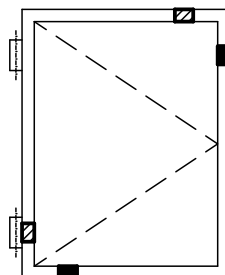

APRIBILE A VASISTAS

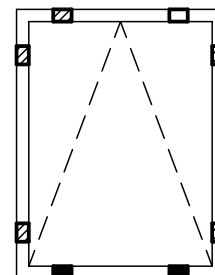

APRIBILE AD ANTA-RIBALTA

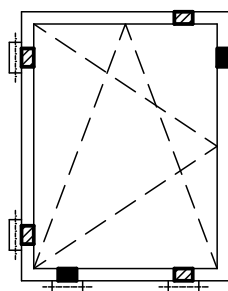

APRIBILE A SPORGERE

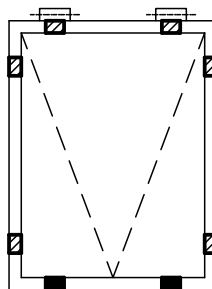

BILICO ORIZZONTALE

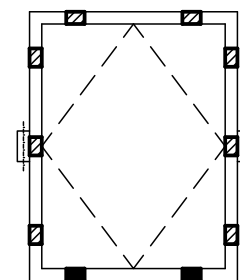

BILICO VERTICALE

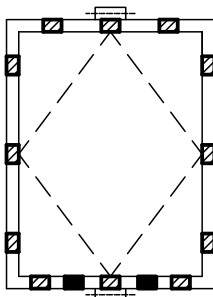

BILICO VERTICALE ECCENTRICO

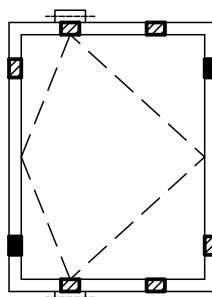

SCORREVOLE

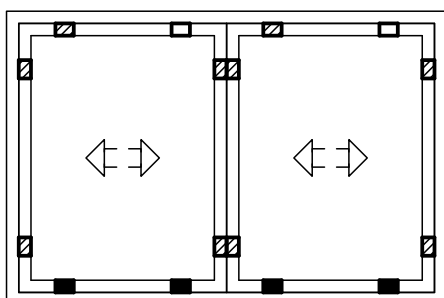

- TASSELLI DI APPOGGIO
- ▨ TASSELLI A CONTRASTO

SPESSORAMENTO DEI VETRI



A SECONDA DELLA TIPOLOGIA DI INFISSO, E' CONVENIENTE EFFETTUARE LO SPESSORAMENTO DELLE VETRAZIONI SECONDO LE INDICAZIONI SEGUENTI.

UNO SPESSORAMENTO ESEGUITO CORRETTAMENTE GARANTISCE LA PERFETTA FUNZIONALITA' DI MOVIMENTAZIONE DELLE ANTE ED UNA MAGGIORE ROBUSTEZZA DEL SERRAMENTO STESSO.

TELAIO FISSO

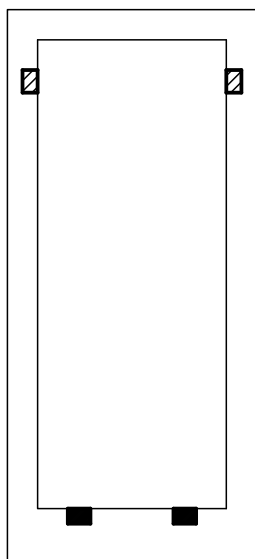

APRIBILE AD ANTA

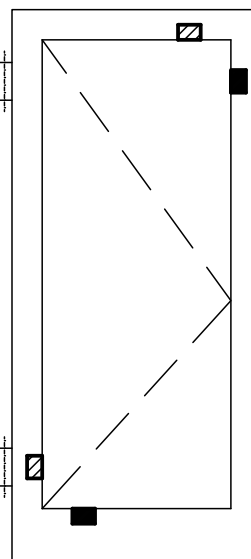

- TASSELLI DI APPOGGIO
- ▨ TASSELLI A CONTRASTO

TELAIO FISSO CON FASCIA

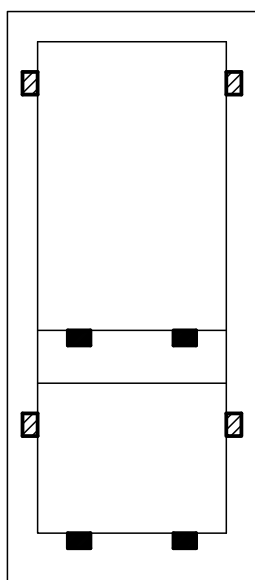

APRIBILE AD ANTA CON FASCIA

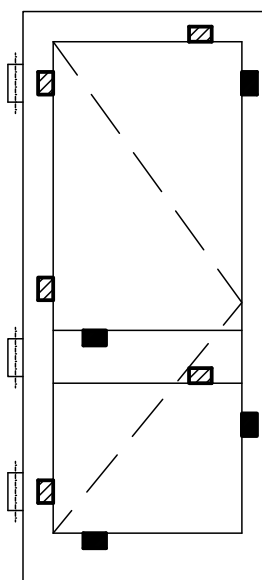

SCHEMA DI POSIZIONAMENTO FISSAGGI A MURO

FINESTRA 1 ANTA

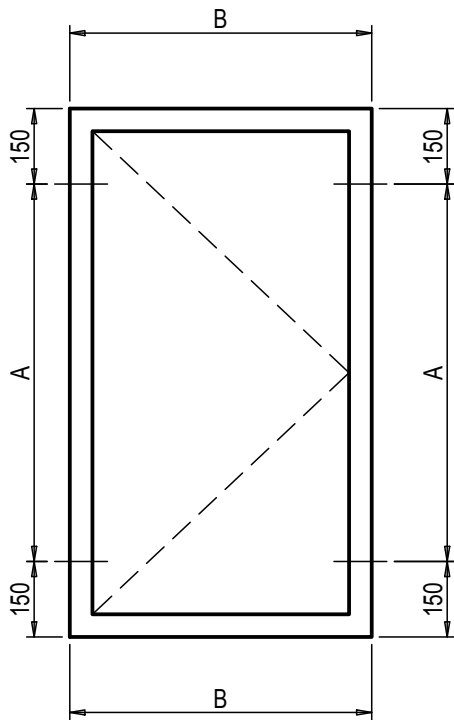

FINESTRA 2 ANTE

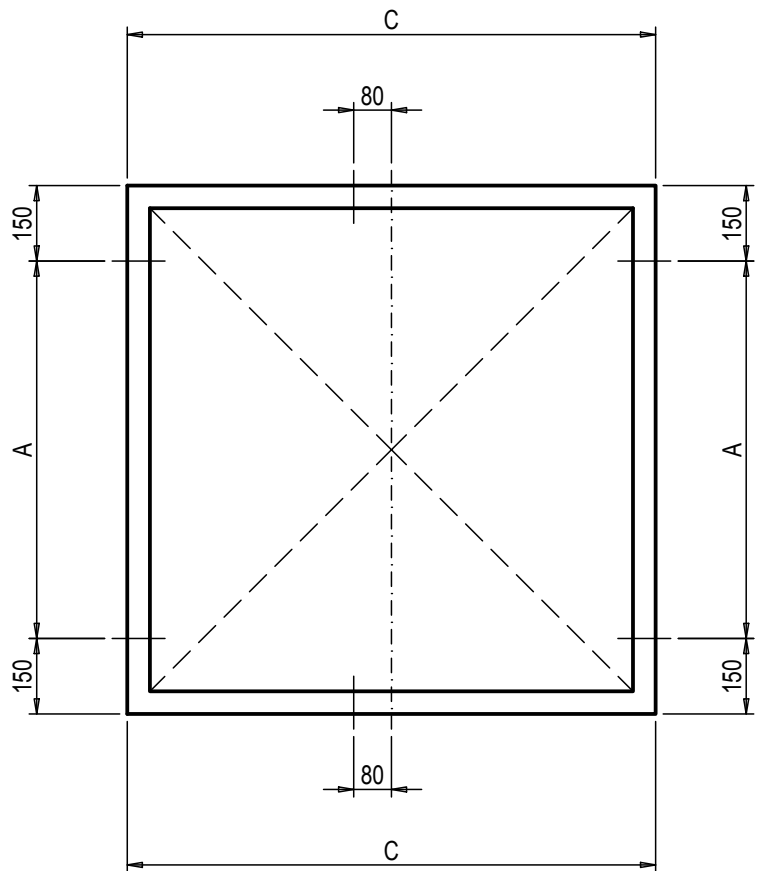

$A \leq 600$ mm

$B \leq 300$ mm NESSUN FISSAGGIO

B DA 300 mm A 800 mm 1 FISSAGGIO POSIZIONE $B/2$

B DA 800 mm A 1200 mm 2 FISSAGGI POSIZIONE $B/3$

$C \leq 800$ mm 1 FISSAGGIO $C/2$

C DA 800 mm A 1200 mm 2 FISSAGGI POSIZIONE $C/3$

C DA 1200 mm A 1600 mm 3 FISSAGGI POSIZIONE $C/4$

N.B. : NELLE FINESTRE A DUE ANTE IL FISSAGGIO CENTRALE DEVE ESSERE SPOSTATO RISPETTO ALL'ASSE DEL TELAIO PER EVITARE L'INTERFERENZA CON GLI ACCESSORI DI RISCONTRO.

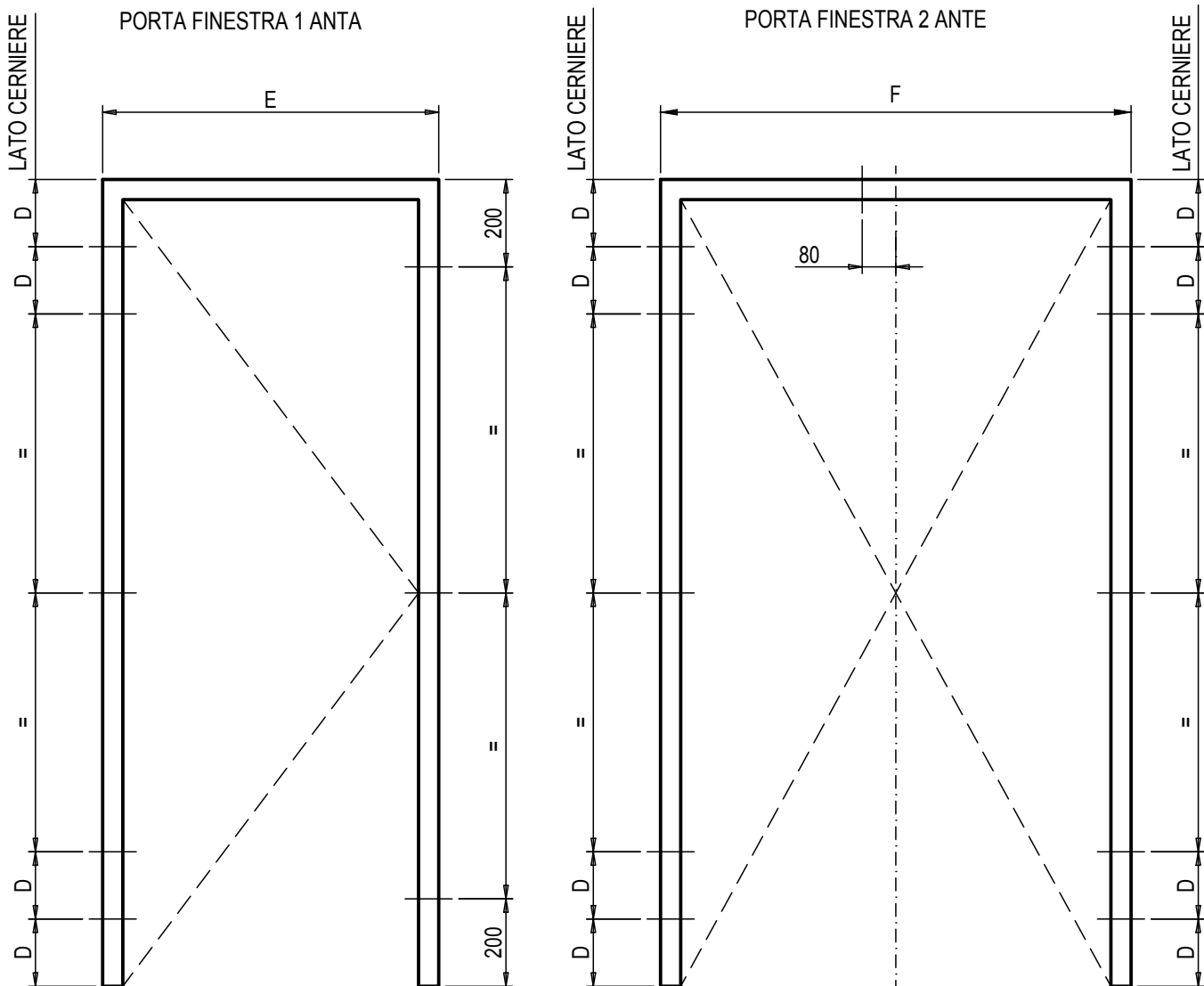

D IN PROSSIMITÀ DELLE CERNIERE

E DA 600 mm A 800 mm 1 FISSAGGIO POSIZIONE E/2
 E DA 800 mm A 1200 mm 2 FISSAGGI POSIZIONE E/3

$F \leq 800$ mm 1 FISSAGGIO F/2
 F DA 800 mm A 1200 mm 2 FISSAGGI POSIZIONE F/3
 F DA 1200 mm A 1600 mm 3 FISSAGGI POSIZIONE F/4

N.B. : NELLE FINESTRE A DUE ANTE IL FISSAGGIO CENTRALE DEVE ESSERE SPOSTATO RISPETTO ALL'ASSE DEL TELAIO PER EVITARE L'INTERFERENZA CON GLI ACCESSORI DI RISCONTRO.

FISSAGGIO ALLA MURATURA

LA POSA DEL SERRAMENTO E' MOLTO IMPORTANTE, PERCHE' IL MODO IN CUI ESSA VIENE ESEGUITA PUO' INCIDERE SULLE PRESTAZIONI FINALI DELL'INFISSO. RICORDIAMO AD ESEMPIO CHE L'ISOLAMENTO ACUSTICO ASSICURATO DAL SERRAMENTO PUO' VENIRE COMPROMESSO SE IL FISSAGGIO ALLE MURATURE LASCIA DEGLI SPAZI LIBERI. ANCHE L'ISOLAMENTO TERMICO PUO' ESSERE VANIFICATO SE NON SI HA CURA DI ELIMINARE I PONTI TERMICI TRA ESTERNO ED INTERNO. EVITARE QUINDI DI POSARE IL SERRAMENTO DIRETTAMENTE A CONTATTO CON PARTI METALLICHE (COME SCOSSALINE O SIMILI).

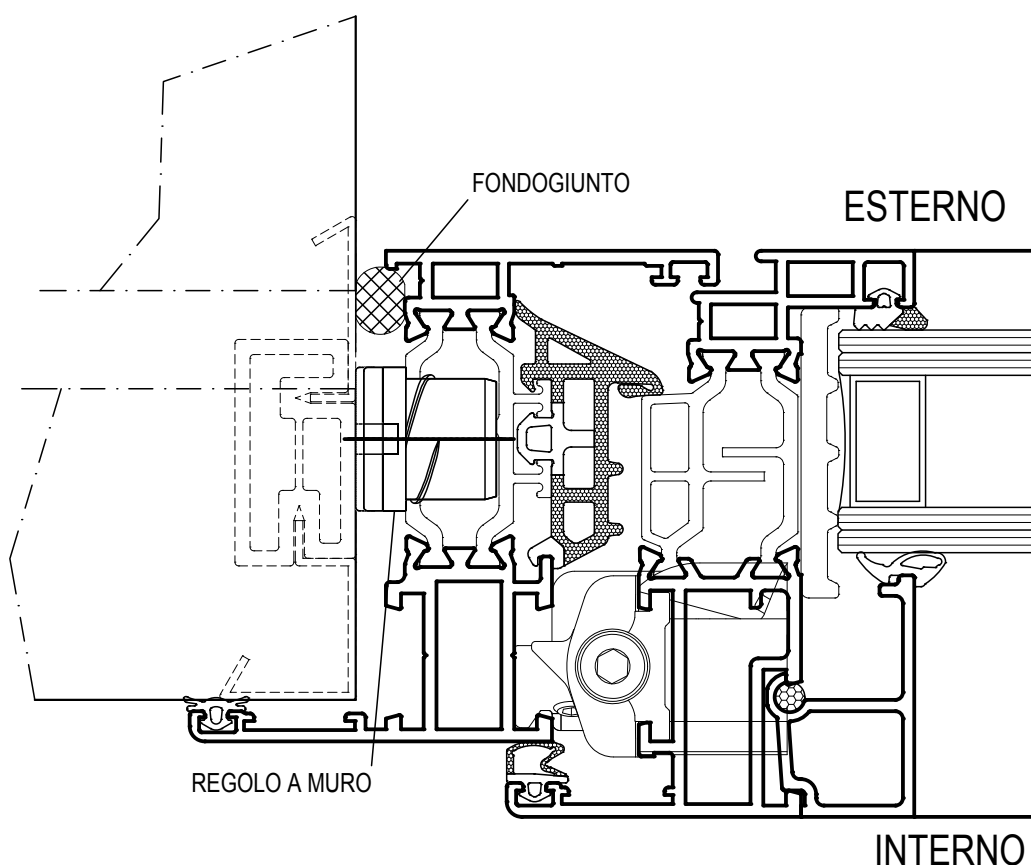

IL FISSAGGIO DEL SERRAMENTO DEVE AVVENIRE PREFERIBILMENTE SU UN CONTROTELAIO, UTILIZZANDO GLI APPOSITI REGOLI DI COMPENSAZIONE CHE CONSENTONO DI ESEGUIRE UNA POSA PRECISA E DI MANTENERE IL SERRAMENTO LIVELLATO, ASSICURANDO L'ISOLAMENTO TERMICO TRA INFISSO E MURATURA.

IL POSIZIONAMENTO DEI REGOLI A MURO VA PREVISTO IN NUMERO ADEGUATO ALLE DIMENSIONI DEL SERRAMENTO, CURANDO IN MODO PARTICOLARE LE ZONE DOVE SONO APPLICATE LE CERNIERE (SI RIMANDA ALLE PAGINE DELLE "LAVORAZIONI" PER MAGGIORI INFORMAZIONI SU QUANTITA' E PASSO)

PER UNA CORRETTA POSA SI CONSIGLIA DI FARE RIFERIMENTO A QUANTO RIPORTATO NELLA NORMA UNI 11673-1

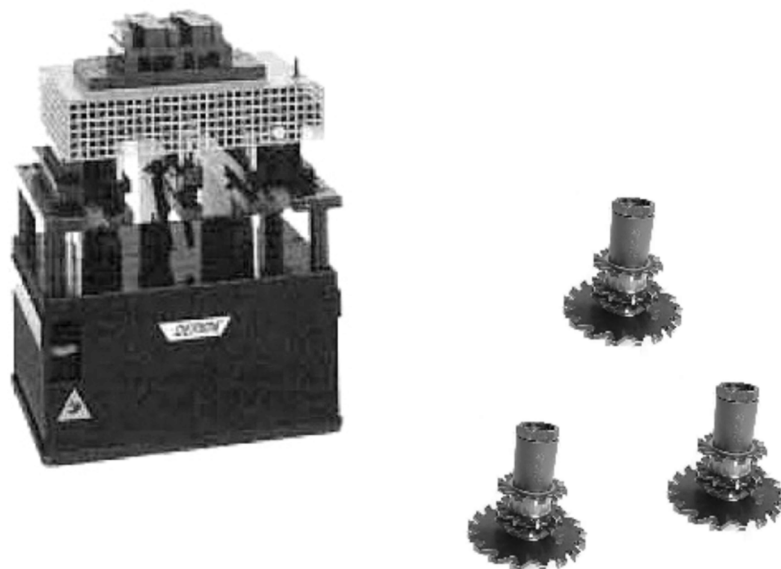

ATTENZIONE :

- LE PUNZONATRICI PNEUMATICHE PRESENTI IN QUESTO CATALOGO, SONO CONFORMI ALLA DIRETTIVA 2006/42/CE E NEI SUCCESSIVI EMENDAMENTI.
- NELLE CONFEZIONI DELLE ATTREZZATURE SONO PRESENTI GLI SCHEMI DI COLLAUDO E LAVORAZIONE DA CONSULTARE PRIMA DELL'UTILIZZO.
- NEL CASO DI PRIMO UTILIZZO DELLE ATTREZZATURE, VERIFICARE SU SPEZZONI DI ALLUMINIO DI PROVA CHE LE REGOLAZIONI PRE-IMPOSTATE NON SIANO STATE MODIFICATE ACCIDENTALMENTE. QUESTO PER EVITARE PROBLEMI DURANTE L' INSTALLAZIONE DI ACCESSORI E FERRAMENTA PER LE TIPOLOGIE DI INFISSI DA COSTRUIRE.



 **INDINVEST LT**

PROFILATI ESTRUSI E FONDERIA

INDINVEST LT S.r.l. a socio unico

S.P. Ninfina II Km 1,200

04012 - Cisterna di Latina (LT)

Tel. +39 06.960.27.1

Società appartenente al Gruppo Indinvest 2000

www.indinvestlt.it

ufficio.tecnico@indinvest.it

